



June 21, 2023

Dan Grimberg
West Hills Land Development
3330 NW Yeon St.
Suite 100
Portland, OR 97210

Re: Case File AR23-0006

Dear Mr. Grimberg,

Enclosed you will find the Administrative Review and Decision on your request for the Middle Housing Land Division for Frog Pond Overlook. Enclosed is a sign-off sheet accepting Conditions of Approval for you to sign and return. Please call us if you have any questions.

Sincerely,

Mandi Simmons
Administrative Assistant

cc James Cramer, Otak Inc. james.cramer@otak.com



June 21, 2023

Notice of Administrative Decision

- Project Name:** Middle Housing Expedited Land Division for Frog Pond Vista Subdivision
- Case File No.:** AR23-0006 Frog Pond Overlook Middle Housing Land Division
- Owner/Applicant:** West Hills Development (Contact: Dan Grimberg)
- Applicant's Representative:** Otak, Inc. (Contact: James Cramer)
- Location:** 7135 SW Frog Pond Lane. The property is specifically known as TLID 00700, Section 12D, Township 3 South, Range 1 West, Willamette Meridian, Clackamas County, Oregon.
- Request:** Middle Housing Expedited Land Division to create 24 middle housing lots within Frog Pond Overlook Subdivision.

On June 21, 2023 an administrative decision was rendered, granting approval with conditions on the above-referenced applications:

The written decision is on file in the planning division. A copy of the applications, all documents and evidence submitted by or on behalf of the applicant and applicable criteria are available for inspection at no cost and will be provided at \$.25 per page at the Wilsonville Planning Division, 29799 SW Town Center Loop E., Wilsonville OR, 97070.

Section 4.232(.05) of the Wilsonville Code and ORS 197.375 provides that this decision may be appealed by the applicant or any person or organization who files comments within the time period established under ORS 197.365.

Note: Any appeal must be filed with the City Recorder. The notice of appeal shall be in writing and indicate the specific qualifying basis for the appeal per ORS 197.375(1)(c). Should you require further information, please contact Georgia McAlister, Associate Planner, with the City Planning Division at 503-682-4960.

For more information, contact the Wilsonville Planning Division at 503-682-4960



Planning Division Staff Report
Administrative Decision

Middle Housing Land Division – Frog Pond Overlook

Date of Report/Decision:	June 20, 2023
Application No.:	AR23-0006 Frog Pond Overlook Middle Housing Land Division
Request Summary:	The City of Wilsonville’s Planning Director, pursuant to Sections 4.030, 4.035, and 4.210 of the Wilsonville Code, is approving a Middle Housing Land Division on six lots
Location:	7135 SW Frog Pond Lane. The property is specifically known as TLID 00700, Section 12D, Township 3 South, Range 1 West, Willamette Meridian, Clackamas County, Oregon.
Owner:	West Hills Development (Contact: Dan Grimberg)
Applicant:	Otak, Inc. (Contact: Kayla Gutierrez)
Comprehensive Plan Map Designation:	Residential Neighborhood
Zone Map Classification:	Residential Neighborhood (RN)
Staff Reviewers:	Georgia McAlister, Associate Planner Amy Pepper, PE, Development Engineering Manager
Action Taken:	<u>Approval with conditions</u> of the requested middle housing land division. The conditions can be found beginning on page 11 of this report.

Applicable Review Criteria:

<u>Development Code:</u>	
Section 4.008	Application Procedures-In General
Section 4.009	Who May Initiate Application
Section 4.010	How to Apply
Section 4.011	How Applications are Processed
Section 4.014	Burden of Proof
Section 4.030	Jurisdiction and Powers of the Planning Director and Community Development Director
Subsection 4.035 (.04)	Site Development Permit Application
Subsection 4.035 (.05)	Complete Submittal Requirement
Section 4.110	Zones
Section 4.118	Standards Applying to Planned Development Zones
Section 4.124	Planned Development Industrial Zone
Section 4.140	Planned Development Regulations
Sections 4.200 through 4.290 as applicable	Land Divisions
Section 4.232	Expedited Land Divisions and Middle Housing Land Divisions
Oregon Revised Statues	197.360, 197.375

Vicinity Map:



Background / Summary:

Frog Pond Overlook is a recently approved 12-lot subdivision within the Frog Pond West Master Plan area. The proposed middle housing land division allows for the creation of separate units of land for residential structures that could otherwise be built on a lot without a land division. The units of land resulting a middle housing land division will collectively be considered a single lot, except for platting and property transfer purposes. Through this middle housing land division the applicant proposes creating twenty-four (24) middle housing units from twelve (12) parent lots for the purposes of constructing two-unit cluster housing. As Frog Pond Overlook has an approved tentative subdivision plat (DB22-0002 and AR23-0007) this application does not propose changes to the streets or parent lots that would impact setbacks, lot lines, access, block size and shape, easements or any changes to the transportation system such as the street network, or pedestrian or bicycle pathways.

Exhibit List:

The following exhibits are hereby entered into the public record as confirmation of consideration of the application as submitted. The exhibit list includes exhibits for Planning Case File AR23-0006.

Planning Staff Materials

- A1. Staff Report and Findings (this document)

Materials from Applicant

- B1.** Narrative
- B2.** Preliminary Plans
 - C0.00 Cover Sheet
 - C1.00 Preliminary Existing Conditions Plan
 - C1.10 Preliminary Middle Housing Land Division Plat
 - C1.30 Preliminary Site Improvements & Composite Utility Plan
 - C2.00 Grading Plan
 - L1.00 Tree Protection Plan
 - L1.10 Tree Inventory
 - L2.00 Landscape Plan
- B3.** Storm Water Report

Procedural Statements and Background Information:

- 1. The statutory 63-day time limit for expedited land divisions applies to this application. The application was received on April, 3, 2023. On May 3, 2023 the application was deemed complete. The City must render a final decision for the request, including any appeals, by July, 5, 2023.
- 2. Surrounding land uses are as follows:

Compass Direction	Zone:	Existing Use:
North:	Clackamas County – RRF5	Rural Residential
East:	Clackamas County – RRF5	Rural Residential
South:	Clackamas County – RRF5	Rural Residential
West:	Clackamas County – RRF5	Rural Residential

- 3. Prior relevant land use actions include:

DB22-0002, Frog Pond Overlook 12-Lot Subdivision

4. The applicant has complied with Sections 4.008 through 4.035 and 4.210 pertaining to review procedures and submittal requirements.
5. Public notice has been provided giving invitation to interested parties to submit information within fourteen (14) days of the date of the Notice of Administrative Action, relevant to the standards pertinent to the proposal and soliciting reason why the application should or should not be approved, or proposing conditions which they believe are necessary for approval to City standards. Property owners within 100 feet of the project boundary have received notice and Staff has not received objections, either in writing or orally, against the proposed modifications.

Findings:

NOTE: Pursuant to Section 4.014 the burden of proving that the necessary findings of fact can be made for approval of any land use or development application rests with the applicant in the case.

As described in the Findings below, the request meets the applicable criteria or will by Conditions of Approval.

General Information

Application Procedures-In General Section 4.008

1. The application is being processed in accordance with the applicable general procedures of this Section.

Initiating Application Section 4.009

2. The application has been submitted on behalf of the property owners West Hills Land Development by representative Dan Grimberg. The application form is signed by Dan Grimberg.

Pre-Application Conference Subsection 4.010 (.02)

3. Planning Division held a pre-application conference on September 16, 2021 (PA21-0021) in accordance with this subsection for the most recent land use approvals. City staff determined an additional pre-application conference was not required for proposed middle housing land division application. A separate meeting was held on February 27, 2023, prior to submitting the application.

Lien Payment before Approval
Subsection 4.011 (.02) B.6

4. No applicable liens exist for the subject property. The application can thus move forward.

General Submission Requirements
Subsection 4.035 (.04) A.

5. The applicant has provided all of the applicable general submission requirements contained in this subsection.

Zoning-Generally
Section 4.110

6. This proposed development is in conformity with the applicable zoning district and general development regulations listed in Sections 4.154 through 4.199 have been applied in accordance with this Section.

Request: AR23-0006 Middle Housing Land Division

Land Division Authorization

Plat Review Authority
Subsection 4.202 (.01) through (.03)

7. The middle housing land division is being reviewed by the Planning Director according to this subsection. The final plat will be reviewed by the Planning Division under the authority of the Planning Director to ensure compliance with the previously-approved tentative partition plat and middle housing land division.

Legally Lot Requirement
Subsection 4.202 (.04) A.

8. It is understood that no parcels will be sold or transferred until the final plat has been approved by the Planning Director and recorded.

Middle Housing Land Divisions

Middle Housing Land Divisions Processed as Expedited Land Divisions
Subsections 4.202 (.05) and 4.232 (.01)

9. The applicant has requested that this application be processed as an Expedited Land Division, therefore this request is being processed as an Expedited Land Division in accordance with this subsection.

Waivers and Variances Applying to Land Divisions
Subsection 4.232 (.02)

10. The property is zoned Residential Neighborhood (RN) and does not contain any requests for waivers or variances from the RN standards, therefore qualifies for approval as an Expedited Land Division.

Criteria for Middle Housing Land Divisions
 Subsection 4.232 (.03) A-G.

11. The required criteria for middle housing land divisions are met as follows:

Standard	Standard Met?			Compliance Notes
	Yes	No	N/A	
Land Division Occupied by Middle Housing	<input checked="" type="checkbox"/>	<input type="checkbox"/>	<input type="checkbox"/>	Middle Housing Units are Proposed
Separate Utilities Provided for Each Unit	<input checked="" type="checkbox"/>	<input type="checkbox"/>	<input type="checkbox"/>	
Easements Provided for Each Unit	<input checked="" type="checkbox"/>	<input type="checkbox"/>	<input type="checkbox"/>	Easements are identified on lots 2 and 10 for the shared driveway of lot 1 and 2 as well as lots 9 and 10
Compliance with Building Code	<input checked="" type="checkbox"/>	<input type="checkbox"/>	<input type="checkbox"/>	Middle housing units are of sufficient area for single family housing that meets Building Code standards. Final compliance to be Determined at Building Permit Review
Required Notes Prohibiting Further Division on Plat	<input checked="" type="checkbox"/>	<input type="checkbox"/>	<input type="checkbox"/>	Plat notes are included on the preliminary tentative Plat
Cluster Housing Standards	<input checked="" type="checkbox"/>	<input type="checkbox"/>	<input type="checkbox"/>	Two units of middle housing are proposed on individual lots and could not be built through a partition or subdivision. The proposed lots range from 3,400 SF to 4,700 SF. Between 43% and 59% of the minimum lot size of 8,000 SF in the R-10 sub-district therefore all proposed lots and units

					are compliant with this standard.
--	--	--	--	--	-----------------------------------

Provisions of Middle Housing Land Divisions

Subsection 4.232 (.04) 1.

- 12.** Two housing units could be built on each of the subject lots without a middle housing land division, therefore this criterion is met.

Units to be Considered Single Lot

Subsection 4.232 (.04) 2. A-B

- 13.** The twelve subject parent lots continue to meet the underlying lot standards of the RN zone. The two-unit cluster housing units will be considered to be two-unit cluster housing units rather than single-family units.

ADU and Middle Housing Allowances

Subsection 4.232 (.04) 2.C.

- 14.** The preliminary plat included in Exhibit A meets the allowance of middle housing units. Each parent lot can contain at least one dwelling unit but may contain additional units consistent with the allowance for middle housing.

Compliance with ORS 197 and OAR 660-046

Subsection 4.232 (.04) 2.D.

- 15.** The preliminary middle housing land division plat included in Exhibit A demonstrates compliance with the middle housing rules and statues included in ORS 197 and OAR 660-046.

Units Must Contain One Dwelling Unit

Subsection 4.232 (.04) 3. A.

- 16.** As demonstrated by the preliminary plat in Exhibit A, the units of land resulting from the middle housing land division will have only one dwelling unit.

Units Not Further Divisible

Subsection 4.232 (.04) 3. B.

- 17.** A note on the preliminary plat in shall state that the middle housing land division units are not further divisible as is conditioned in Condition of Approval PD4.

Procedures and Requirements for Expedited Land Divisions and Middle Housing Land Divisions

Subsection 4.232 (.05) A. 1.-4.

- 18.** The middle housing expedited land division is being processed administratively in accordance with this subsection. The Development Review Board and City Council do not have call up authority to review this decision.

Divisions for Land Occupied by Middle Housing
Subsection 4.232 (.05) B.

19. The request involves vacant land therefore this standard does not apply.

Multiple Middle Housing Land Divisions as Single Application
Subsection 4.232 (.05) C.

20. The application includes a tentative plat in Exhibit A for a middle housing land division for twenty-four (24) lots.

Optional Concurrent Review
Subsection 4.232 (.05) D.

21. The applicant elected to have the middle housing land division reviewed concurrently with a tentative subdivision plat revision. The tentative subdivision plat for Frog Pond Overlook was reviewed and approved by the Development Review Board under application DB22-0002. A revised tentative plat has been reviewed and approved in an administrative process under application AR23-0007.

Lots of Record

Defining Lots of Record
Section 4.250

22. The subject property is a legal lot of record.

Action Taken and Conditions of Approval

THEREFORE, based on Staff analysis and Findings 1-22 above, the Planning Director hereby **approves** the application as requested, subject to the following Conditions of Approval:

Planning Division Conditions:

PD 1.	The applicant/owner shall assure that the parcels not be sold or conveyed until such as time as the final plat is recorded with the county.
PD 2.	The applicant/owner shall submit an application for Final Plat review and approval on the Planning Division Site Development Application and Permit form. The Applicant/Owner shall also provide materials for review by the City’s Planning Division in accordance with Section 4.220 of City’s Development Code. The Final Plat shall be prepared in substantial accord with the middle housing land division as approved by this action and as amended by these conditions, except as may be subsequently altered by minor revisions approved by the Planning Director.
PD 3.	The applicant/owner shall illustrate existing and proposed easements on the Final Plat.
PD 4.	On the final plat, the applicant/owner shall state the middle housing land division units are not further divisible.
PD 5.	The conditions of approval contained in DB22-0002 shall continue to apply to this application.

The following Conditions of Approval are provided by the Engineering, Natural Resources, or Building Divisions of the City’s Community Development Department or Tualatin Valley Fire and Rescue, all of which have authority over development approval. A number of these Conditions of Approval are not related to land use regulations under the authority of the Development Review Board or Planning Director. Only those Conditions of Approval related to criteria in Chapter 4 of Wilsonville Code and the Comprehensive Plan, including but not limited to those related to traffic level of service, site vision clearance, recording of plats, and concurrency, are subject to the Land Use review and appeal process defined in Wilsonville Code and Oregon Revised Statutes and Administrative Rules. Other Conditions of Approval are based on City Code chapters other than Chapter 4, state law, federal law, or other agency rules and regulations. Questions or requests about the applicability, appeal, exemption or non-compliance related to these other Conditions of Approval should be directed to the City Department, Division, or non-City agency with authority over the relevant portion of the development approval.

Engineering Division Conditions:

Request: AR23-0006 Preliminary Development Plan

PF 1.	Public Works Plans and Public Improvements shall conform to the “Public Works Plan Submittal Requirements and Other Engineering Requirements” in Exhibit C1 and to specifics as found in the Frog Pond West Mater Plan (July 17, 2017).
--------------	---

Case File #: AR23-0006

Approved:



Digitally signed by Daniel Pauly
Date: 2023.06.20 13:00:23 -07'00'

Daniel Pauly, Planning Manager for
Miranda Bateschell, Planning Director

Date

Section 4.022(.01) of the Wilsonville Code provides that this decision may be appealed by the Applicant and party entitled to notice or adversely affected or aggrieved or called up for review by the Development Review Board. The notice of appeal shall indicate the nature of the action or interpretation that is being appealed or called up. The appeal shall regard a determination of the appropriateness of the action or interpretation of the Code requirements involved in the decision.

*Note: The decision of the Planning Director may be appealed by an affected party or by three (3) Board members in accordance with Section 4.017 except that the review shall be of the record supplemented by oral commentary relevant to the record presented on behalf of the Applicant and the Planning Director. Any appeal must be filed with the City Recorder within fourteen (14) calendar days of the notice of the decision. The notice of appeal shall be in writing and indicate the specific issue(s) being appealed and the reason(s) therefore. Should you require further information, please contact Georgia McAlister, Associate Planner, with the City Planning Division at 503-682-4960. Last day to appeal: **4:00 P.M. on July 3, 2023.***

For more information, contact the Wilsonville Planning Division at 503-682-4960.

Sign-off accepting Conditions of Approval

Case File # AR23-0006

Project Name: Middle Housing Land Division for Frog Pond Overlook

The Conditions of Approval have been received and accepted by:



Signature

Director of Land Development 7/12/23

Title

Date

Signature

Title

Date

This decision is not effective unless this form is signed and returned to the planning office as required by WC Section 4.140(.09)(L).

Adherence to Approved Plan and Modification Thereof: The Applicant shall agree in writing to be bound, for her/himself and her/his successors in interest, by the conditions prescribed for approval of a development.

Please sign and return to:

Shelley White
Planning Administrative Assistant
City of Wilsonville
29799 SW Town Center Loop E
Wilsonville OR 97070



Frog Pond Overlook Subdivision

Wilsonville, Oregon

Request for:
Expedited Land Division for Middle Housing Land Division

Prepared for:
West Hills Land Development
3330 NW Yeon Ave, Suite 200
Portland, OR 97210

Prepared by:
Otak, Inc.
808 SW Third Avenue, Suite 800
Portland, OR 97204

May 1, 2023

Project No. 021249.000

REQUEST

An Expedited Land Division for a proposed Middle Housing Land Division is requested to be completed for the Frog Pond Overlook development that received a Tentative Subdivision Plat (SUBD22-0001) for a 12-lot subdivision. The request is to further divide the property into a total of 24 middle housing units. The site is located within the West Neighborhood of the Frog Pond Area Plan boundaries.

SITE INFORMATION

SUBJECT SITE: 7315 SW Frog Pond Lane
TLID 31W12D 700

SITE AREA: 4.07 acres

COMPREHENSIVE PLAN DESIGNATION: Residential Neighborhood RN

ZONING DESIGNATION: Residential Neighborhood RN

APPLICANT/PROPERTY OWNER

APPLICANT/OWNER: West Hills Land Development LLC
3330 NW Yeon Ave, Suite 200
Portland, OR 97210
Contact: Dan Grimberg
503.726.7033
dan@westhillsdevelopment.com

PROJECT DEVELOPMENT TEAM

**APPLICANT'S REPRESENTATIVE/
LAND USE PLANNER:** Otak, Inc.
808 SW Third Avenue, Suite 800
Portland, OR 97204
Contact: James Cramer
971.230.5994
James.cramer@otak.com

CIVIL ENGINEER: Contact: Keith Buisman, PE
503.415.2337
Keith.buisman@otak.com

LANDSCAPE ARCHITECT: Contact: Gabriel Kruse, PLA
503.415.2402
gabriel.kruse@otak.com

SURVEYOR: Contact: Mike Spelts, PLS
503.415.2321
mike.spelts@otak.com

**STORMWATER
ENGINEER:**

Contact: Rose Horton
503.530.2374
rose.horton@otak.com

ARBORIST:

Portland Tree Consulting
PO Box 19042
Portland, OR 97280
Contact: Peter Torres, MF
503.452.8160
peter@pdxtreeconsulting.com

TABLE OF CONTENTS

	Page
1. Requests	1
2. Project Description	1
3. Zoning Regulations.....	3
<i>A. Section 4.035 Site Development Permits</i>	<i>3</i>
<i>B. Section 4.113. Standards Applying to Residential Developments In Any Zone.....</i>	<i>5</i>
<i>C. Section 4.118 Standards Applying in all Planned Development Zones.....</i>	<i>8</i>
<i>D. Section 4.124. Standards applying to all Planned Development Residential Zones.....</i>	<i>9</i>
<i>E. Section 4.127. Residential Neighborhood (RN) Zone.....</i>	<i>12</i>
<i>F. Section 4.139. Significant Resource Overlay Zone (SROZ) Ordinance.....</i>	<i>26</i>
<i>G. Section 4.140. Planned Development Regulations.....</i>	<i>32</i>
4. General Development Regulations.....	37
<i>A. Section 4.154. On-site Pedestrian Access and Circulation.....</i>	<i>37</i>
<i>B. Section 4.155. General Regulations - Parking, Loading and Bicycle Parking.....</i>	<i>38</i>
<i>C. Section 4.156. Sign Code Regulations.....</i>	<i>41</i>
<i>D. Section 4.167. General Regulations - Access, Ingress and Egress.....</i>	<i>41</i>
<i>E. Section 4.169. General Regulations – Double-Frontage Lots.....</i>	<i>42</i>
<i>F. Section 4.171. General Regulations Protection of Natural Features and Other Resources.....</i>	<i>42</i>
<i>G. Section 4.175. Public Safety and Crime Prevention.....</i>	<i>45</i>
<i>H. Section 4.176. Landscaping, Screening, and Buffering.....</i>	<i>45</i>
<i>I. Section 4.177. Street Improvement Standards.....</i>	<i>55</i>
<i>J. Section 4.180. Exceptions and Modifications - Projections into Required Yards.....</i>	<i>60</i>
<i>K. Section 4.181. Exceptions & Modifications - Height Limits.....</i>	<i>61</i>
<i>L. Section 4.182. Exceptions and Modifications - Setback Modifications.....</i>	<i>61</i>
<i>M. Section 4.197. Zone Changes and Amendments To This Code – Procedures.....</i>	<i>61</i>
5. Land Divisions.....	62
<i>A. Section 4.210. Application Procedure.....</i>	<i>62</i>
<i>B. Section 4.232. - Expedited Land Divisions and Middle Housing Land Divisions.....</i>	<i>64</i>
<i>C. Section 4.236. General Requirements - Streets.....</i>	<i>68</i>
<i>D. Section 4.237. General Requirements – Other.....</i>	<i>70</i>
<i>E. Section 4.262. Improvements - Requirements.....</i>	<i>73</i>
6. Underground Utilities	74
<i>A. Section 4.300. General.....</i>	<i>74</i>
<i>B. Section 4.320. Requirements.....</i>	<i>75</i>
7. Conclusion.....	75

APPENDICES

Appendix A	Legal Description
Appendix B	Stormwater Preliminary Drainage Report dated March 2023, by Otak, Inc.
Appendix C	Arborist Report by Portland Tree Consulting
Appendix D	Example House Architecture
Appendix E	TVFR Communication

REDUCED SIZE PLAN SET

Sheet C0.00	Cover Sheet
Sheet C1.00	Existing Conditions and Demo Plan
Sheet C1.10	Site Plan
Sheet C1.20	Street Cross Sections
Sheet C1.30	Composite Utility Plan
Sheet C1.40	Prelim. Subdivision Plat & Horizontal Control
Sheet C2.00	Grading Plan
Sheet L1.00	Tree Protection Plan
Sheet L1.10	Tree Inventory
Sheet L2.00	Landscape Plan
Sheet L2.10	Tract Landscape Plan
Sheet L3.00	Landscape Notes and Details

Note: *All plan sheets are also separately bound in a larger format within the development application submittal.*

1. Requests

A Middle Housing Division is requested for the Frog Pond Overlook development that was previously approved via project number DB22-0002, for an annexation, zone map amendment, a 12-lot subdivision, and infrastructure improvements of the subject property. Approval included a recommendation of approval by the Development Review Board (DRB) via Resolution 407 and subsequent City Council (CC) approval through Ordinance 868 for the overall Frog Pond Overlook development.

Middle Housing Land Division approval is required to adjust the previously approved 12-lot subdivision to 24 middle housing units.

2. Project Description

The subject site is located within the Frog Pond West Master Plan area of the City of Wilsonville. It is the applicant's tenth development in Frog Pond West. The subdivision will connect to the concurrently proposed Frog Pond Terrace to the south, previously approved Frog Pond Vista subdivision to the northeast, and Morgan Farm subdivision to the south, blending together as one cohesive neighborhood consistent with the Frog Pond West Master Plan.

The applicant, West Hills Land Development LLC, have previously been issued approval for the Frog Pond Overlook development via DB22-0002. The proposal (DB22-0002) received a recommendation of approval by the DBR (resolution 407) and subsequent approval from CC (Ordinance 868). Specifically, the proposal included the following approvals:

- Annexation (ANNX22-0001)
- Zone Map Amendment (ZONE22-0002)
- Stage 1 Preliminary Plan (STG122-0002)
- Stage 2 Final Plan (STG222-0002)
- Site Design Review of Parks and Open Space (SDR22-0002)
- Tentative Subdivision Plat (SUBD22-0001)
- Type C Tree Removal Plan (TPLN22-0001)
- Abbreviated SROZ Map Verification (SROZ22-0004)

The previously approved zone map amendment (ZONE22-0022) changed the property to Residential Neighborhood (RN) to be used as residential use and the Tentative Subdivision Plat (SUBD22-0001) for a 12-lot subdivision. Through a separate applicant, the applicant has proposed to revise the tentative plat by shifting the various boundary lines. As a result, the 12-lots and two-tracts within the subdivision will result in the following areas per the table below:

Lot Areas Before Middle House Land Division	
Lot	Revised Tentative Plat Area (SF)
1	8,080
2	8,039
3	8,315
4	8,094
5	8,088
6	8,151
7	9,019
8	9,043
9	9,145
10	8,984
11	8,539
12	8,096
Tract A	44,694
Tract B	1,599

The requested Middle Housing Land Division will further divide the Frog Pond Overlook into a total of 21-lots (18 middle housing units and 3 standard lots). Specifically, lots 1-6, and 9-11 (9-lots total) of the Frog Pond Overlook revised tentative plat will be further divided to incorporate middle housing units for future development. The proposed Middle Housing lot areas are as follow:

Lot Area Analysis			
Revised Tentative Plat		Middle Housing Division	
Lot	Area (SF)	Lot	Area (SF)
1	8,080	24	4,179
		23	3,901
2	8,039	22	4,020
		21	4,019
3	8,315	20	3,897
		19	4,418
4	8,094	18	4,286
		17	3,809
5	8,088	16	4,037
		15	4,050
6	8,151	14	3,935
		13	4,216
7	9,019	12	4,245

		11	4,774
8	9,043	10	4,422
		9	4,621
9	9,145	8	4,735
		7	4,410
10	8,984	6	4,723
		5	4,260
11	8,539	4	4,266
		3	4,272
12	8,096	2	4,032
		1	4,064
Tract A*	44,694	Tract A*	44,694
Tract B*	1,599	Tract B*	1,599

**Not proposed for Middle Housing Land Division*

3. Zoning Regulations

A. Section 4.035 Site Development Permits

[...]

(.04) *Site Development Permit Application.*

- A. *An application for a Site Development Permit shall consist of the materials specified as follows, plus any other materials required by this Code.*
- 1. A completed Permit application form, including identification of the project coordinator, or professional design team.*

Response: Completed application forms have been submitted.

- 2. An explanation of intent, stating the nature of the proposed development, reasons for the Permit request, pertinent background information, information required by the development standards and other information specified by the Director as required by other sections of this Code because of the type of development proposal or the area involved or that may have a bearing in determining the action to be taken. As noted in Section 4.014, the applicant bears the burden of proving that the application meets all requirements of this Code.*

Response: This narrative includes a description of the nature of the proposed development, reasons for the request, pertinent background information, and responses to applicable criteria.

- 3. Proof that the property affected by the application is in the exclusive ownership of the applicant, or that the applicant has the consent of all individuals or partners in ownership of the affected property.*

Response: The submittal includes application forms signed by the property owners and the applicant, verifying that all owners consent to the application.

- 4. Legal description of the property affected by the application.*

Response: A legal description of the property is included in Appendix A.

5. *The application shall include conceptual and quantitatively accurate representations of the entire development sufficient to judge the scope, size and impact of the development on the community, public facilities and adjacent properties; and except as otherwise specified in this Code, shall be accompanied by the following information,*

Response: The exhibits and reports included with this submittal provide this information.

6. *Unless specifically waived by the Director, the submittal shall include: ten (10) copies folded to 9" x 12" or (one (1) set of full-sized scaled drawings and nine (9) 8 1/2" x 11" reductions of larger drawings) of the proposed Site Development Plan, including a small scale vicinity map and showing:*
 - a. *Streets, private drives, driveways, sidewalks, pedestrian ways, off-street parking, loading areas, garbage and recycling storage areas, power lines and railroad tracks, and shall indicate the direction of traffic flow into and out of off-street parking and loading areas, the location of each parking space and each loading berth and areas of turning and maneuvering vehicles.*
 - b. *The Site Plan shall indicate how utility service , including sanitary sewer, water and storm drainage, are to be provided. The Site Plan shall also show the following off-site features: distances from the subject property to any structures on adjacent properties and the locations and uses of streets, private drives, or driveways on adjacent properties.*
 - c. *Location and dimensions of structures, utilization of structures, including activities and the number of living units.*
 - d. *Major existing landscaping features including trees to be saved, and existing and proposed contours.*
 - e. *Relevant operational data, drawings and/or elevations clearly establishing the scale, character and relationship of buildings, streets, private drives, and open space.*
 - f. *Topographic information sufficient to determine direction and percentage of slopes, drainage patterns, and in environmentally sensitive areas, e.g., flood plain, forested areas, steep slopes or adjacent to stream banks, the elevations of all points used to determine contours shall be indicated and said points shall be given to true elevation above mean sea level as determined by the City Engineer. The base data shall be clearly indicated and shall be compatible to City datum if bench marks are not adjacent. The following intervals shall be shown:*
 - i. *One (1) foot contours for slopes of up to five percent (5%);*
 - ii. *Two (2) foot contours for slopes of from six percent (6%) to twelve percent (12%);*
 - iii. *Five (5) foot contours for slopes of from twelve percent (12%) to twenty percent (20%). These slopes shall be clearly identified, and*
 - iv. *Ten (10) foot contours for slopes exceeding twenty percent (20%).*
 - g. *A tabulation of land area, in square feet, devoted to various uses such as building area (gross and net rentable), parking and paving coverage, landscaped area coverage and average residential density per net acre.*
 - h. *An application fee as set by the City Council.*
 - i. *If there are trees in the development area, an arborist's report, as required in Section 4.600. This report shall also show the impacts of grading on the trees.*

- j. *A list of all owners of property within 250 feet of the subject property, printed on label format. The list is to be based on the latest available information from the County Assessor.*

Response: Along with various appendices associated with the proposed Middle Housing Land Division a plan set with the following sheets has been included with the submission to provide the opportunity for a thorough review:

Sheet C0.00	Cover Sheet
Sheet C1.00	Existing Conditions and Demo Plan
Sheet C1.10	Site Plan
Sheet C1.20	Street Cross Sections
Sheet C1.30	Composite Utility Plan
Sheet C1.40	Prelim. Subdivision Plat & Horizontal Control
Sheet C2.00	Grading Plan
Sheet L1.00	Tree Protection Plan
Sheet L1.10	Tree Inventory
Sheet L2.00	Landscape Plan
Sheet L2.10	Tract Landscape Plan
Sheet L3.00	Landscape Notes and Details

B. Section 4.113. Standards Applying to Residential Developments In Any Zone

(.01) Open Space:

[...]

B. Applicability.

[...]

2. These standards do not apply to the following:
 - a. Partitions for non-Multi-family development. However, serial or adjacent partitions shall not be used to avoid the requirements.
 - b. Middle Housing Land Divisions.

Response: The proposal is to complete a Middle Housing Land Division therefore the standards of this section do not apply.

(.02) Building Setbacks

[...]

B. For lots not exceeding 10,000 square feet:

1. *Minimum front yard setback: 15 feet, with open porches allowed to extend to within ten feet of the property line.*
2. *Minimum side yard setback: One story: five feet; Two or more stories: seven feet. In the case of a corner lot, abutting more than one street or tract with a private drive, the side yard on the street side of such lot shall be not less than ten feet.*
3. *In the case of a key lot, the front setback shall equal one-half the sum of depth of the required yard on the adjacent corner lot along the street or tract with a private drive upon which the key lot faces and the setback required on the adjacent interior lot.*
4. *No structure shall be erected within the required setback for any future street shown within the City's adopted Transportation Master Plan or Transportation Systems Plan.*
5. *Minimum setback to garage door or carport entry: 20 feet. Wall above the garage door may project to within 15 feet of property line, provided that clearance to garage door is maintained. Where access is taken from an alley, garages or carports may be located no less than four feet from the property line adjoining the alley.*

6. *Minimum rear yard setback: One story: 15 feet. Two or more stories: 20 feet. Accessory buildings on corner lots must observe the same rear setbacks as the required side yard of the abutting lot.*
7. *Cottage Cluster Setbacks: Any minimum setback in 1.—3. or 6. above that would exceed ten feet for a cottage cluster shall be ten feet.*
8. *Townhouse Setbacks: No setback is required along property lines where townhouses are attached.*

Response: The site is within the Frog Pond West Master Plan Area and the RN zone is being applied through this application. The site is subject to the setback requirements of Section 4.127, which are addressed in the responses to that section.

(.03) Height Guidelines. *The Development Review Board may regulate heights as follows:*

- A. *Restrict or regulate the height or building design consistent with adequate provision of fire protection and fire-fighting apparatus height limitations.*
- B. *To provide buffering of low density developments by requiring the placement of buildings more than two stories in height away from the property lines abutting a low density zone.*
- C. *To regulate building height or design to protect scenic vistas of Mt. Hood or the Willamette River from greater encroachments than would occur if developed conventionally.*

Response: No low-density developments are adjacent to the site and no scenic vistas have been identified on the site. No height regulation is needed.

(.04) Residential uses for treatment or training

- A. *Residential Homes, as defined in Section 4.001, shall be permitted in any location where a single-family dwelling is permitted.*
- B. *Residential Facilities, as defined in Section 4.001, shall be permitted in any location where multiple-family dwelling units are permitted.*

Response: No residential homes or facilities are proposed. These standards are not applicable.

(.05) Off Street Parking

Off-street parking shall be provided as specified in Section 4.155.

Response: The provisions of Section 4.155 are addressed in Section IV.B of this narrative.

(.06) Signs

Signs shall be governed by the provisions of Sections 4.156.01 – 4.156.11.

Response: The provisions of Sections 4.156.01-11 are addressed in Section IV.C of this narrative.

(.07) Fences

- A. *The maximum height of a sight-obscuring fence located in the required front yard of a residential development shall not exceed four feet.*
- B. *The maximum height of a sight-obscuring fence located in the side yard of a residential lot shall not exceed four feet forward of the building line and shall not exceed six feet in height in the rear yard, except as approved by the Development Review Board. Except, however, that a fence in the side yard of residential corner lot may be up to six feet in height, unless a greater restriction is imposed by the Development Review Board acting on an application. A fence of up to six feet in height may be constructed with no setback*

along the side, the rear, and in the front yard of a residential lot adjoining the rear of a corner lot as shown in the attached Figure.

- C. *Notwithstanding the provisions of Section 4.122(10)(a) and (b), the Development Review Board may require such fencing as shall be deemed necessary to promote and provide traffic safety, noise mitigation, and nuisance abatement, and the compatibility of different uses permitted on adjacent lots of the same zone and on adjacent lots of different zones.*
- D. *Fences in residential zones shall not include barbed wire, razor wire, electrically charged wire, or be constructed of sheathing material such as plywood or flakeboard.*

Response: The site is located within Frog Pond West and is subject to these standards except for the standards of 4.127(0.17) related to the Boeckman Road and Stafford Road frontages. Because the property does not have frontage on Boeckman Road or Stafford Road, the provisions of 4.127(0.17) are not applicable to this proposal. Fences on residential lots are not proposed with this application and shall be subject to building permit review at time of future development.

(.08) Corner Vision

Vision clearance shall be provided as specified in Section 4.177, or such additional requirements as specified by the City Engineer.

Response: The provisions of Section 4.177 are addressed in Section IV.I of this narrative.

(.9) Prohibited Uses

- A. *Uses of structures and land not specifically permitted in the applicable zoning districts.*
- B. *The use of a trailer, travel trailer or mobile coach as a residence, except as specifically permitted in an approved RV park.*
- C. *Outdoor advertising displays, advertising signs, or advertising structures except as provided in Sections 4.156.05, 4.156.07, 4.156.09, and 4.156.10.*

Response: No prohibited uses are proposed. These provisions are not applicable.

(.10) Accessory Dwelling Units

Accessory Dwelling Units, are permitted subject to standards and requirements of this Subsection. [...]

Response: No accessory dwelling units are proposed. These standards are not applicable.

(.11) Reduced Setback Agreements

The following procedure has been created to allow the owners of contiguous residential properties to reduce the building setbacks that would typically be required between those properties, or to allow for neighbors to voluntarily waive the solar access provisions of Section 4.137. Setbacks can be reduced to zero through the procedures outlined in this subsection.[...]

Response: No reduced setbacks are requested through these provisions.

(.12) Bed and Breakfasts

[...]

Response: No bed and breakfasts are proposed. These standards are not applicable.

- (.13)** *The Planning Director and Development Review Board shall, in making their determination of compliance in attaching conditions, consider the effects of this action on*

the availability and cost of needed housing. The provisions of this section shall not be used in such a manner that additional conditions, either singularly or cumulatively, have the effect of unnecessarily increasing the cost of housing or effectively excluding a needed housing type. However, consideration of these factors shall not prevent the Board or Planning Director from imposing conditions of approval necessary to meet the minimum requirements of the Comprehensive Plan and Code.

Response: Acknowledged.

(.14) Design Standards for Detached Single-family and Middle Housing.

- A. *The standards in this subsection apply in all zones, except as indicated in 1.—2. below:*
1. *The Façade Variety standards in Subsection C.1. do not apply in the Village Zone or Residential Neighborhood Zones, as these zones have their own variety standards, except that the standards do apply within middle housing development with multiple detached units on a single lot which the standards of these zones do not address;*
 2. *The entry orientation and window standards for triplexes, quadplexes, and townhouses in Subsections D.1-2. and E. 2-3. do not apply in the Village Zone or Residential Neighborhood Zone as these zones have their own related standards applicable to all single-family and middle housing.*

Response: It is acknowledged that the standards of this section shall apply to the proposed middle housing upon future development. The individual dwelling designs will be reviewed at the time of building permit submittal. Appendix D has been included as a visual example of proposed dwellings architecture that have been approved via DB22-0002 Frog Pond Overlook which received a recommendation of approved by DRB (resolution 407) and subsequently was approved by CC (Ordinance 868).

C. Section 4.118 Standards Applying in all Planned Development Zones.

- (.01) Height Guidelines:** *In “S” overlay zones, the solar access provisions of Section 4.137 shall be used to determine maximum building heights. In cases that are subject to review by the Development Review Board, the Board may further regulate heights as follows:
[...]*

Response: The subject site is not located within the “S” overlay zone. These standards are not applicable.

- (.02) Underground Utilities** *shall be governed by Sections 4.300 to 4.320. All utilities above ground shall be located so as to minimize adverse impacts on the site and neighboring properties.*

Response: The provisions of Sections 4.300 to 4.320 are addressed in Section VI of this narrative.

- (.03) Notwithstanding the provisions of Section 4.140 to the contrary, the Development Review Board, in order to implement the purposes and objectives of Section 4.140, and based on findings of fact supported by the record may:**
- A. *Waive the following typical development standards:*
1. *Minimum lot area;*
 2. *Lot width and frontage;*
 3. *Height and yard requirements;*
 4. *Lot coverage;*

5. Lot depth;
6. Street widths;
7. Sidewalk requirements;
8. Height of buildings other than signs;
9. Parking space configuration and drive aisle design;
10. Minimum number of parking or loading spaces;
11. Shade tree islands in parking lots, provided that alternative shading is provided;
12. Fence height;
13. Architectural design standards;
14. Transit facilities;
15. On-site pedestrian access and circulation standards;
16. Solar access standards, as provided in section 4.137;
17. Open space in the Residential Neighborhood zone; and
18. Lot orientation.

Response: There are no waivers requested to these standards.

B. The following shall not be waived by the Board, unless there is substantial evidence in the whole record to support a finding that the intent and purpose of the standards will be met in alternative ways:

1. Open space requirements in residential areas, except that the Board may waive or reduce open space requirements in the Residential Neighborhood zone. Waivers in compliance with [Section] 4.127(.08)(B)(2)(d);
2. Minimum density standards of residential zones. The required minimum density may be reduced by the Board in the Residential Neighborhood zone in compliance with [Section] 4.127(.06) B; and
3. Minimum landscape, buffering, and screening standards.

Response: The applicant is not requesting to waive minimum density standards. This section is not applicable.

C. The following shall not be waived by the Board, unless there is substantial evidence in the whole record to support a finding that the intent and purpose of the standards will be met in alternative ways, and the action taken will not violate any applicable federal, state, or regional standards:

1. Maximum number of parking spaces;
2. Standards for mitigation of trees that are removed;
3. Standards for mitigation of wetlands that are filled or damaged; and
4. Trails or pathways shown in the Parks and Recreation Master Plan.

Response: There are no request for waivers for these items. This section is not applicable.

[...]

D. Section 4.124. Standards applying to all Planned Development Residential Zones.

(.01) Permitted Uses:

- A. Open Space.
- B. Single-Family Dwelling Units.
- C. Duplexes, triplexes, quadplexes, townhouses.
- D. Cluster housing, including cottage clusters.

- E. *Multiple-Family Dwelling Units.*
- F. *Public parks, playgrounds, recreational and community buildings and grounds, tennis courts, and similar recreational uses, all of a non-commercial nature, provided that any principal building or public swimming pool shall be located not less than 45 feet from any other lot.*
- G. *Manufactured homes.*

Response: The proposed development includes open space as well as detached and attached single-family dwelling units for future development. These uses are permitted uses in the PDR zones.

(.02) Permitted accessory uses to single family and middle housing:

- A. *Accessory uses, buildings and structures customarily incidental to any of the principal permitted uses listed above, and located on the same lot.*
- B. *Living quarters without kitchen facilities for persons employed on the premises or for guests. Such facilities shall not be rented or otherwise used as a separate dwelling unless approved as an accessory dwelling unit or duplex.*
- C. *Accessory dwelling units, subject to the standards of Section 4.113 (.10).*
- D. *Home occupations.*
- E. *A private garage or parking area.*
- G. *Temporary real estate signs, small announcement or professional signs, and subdivision signs, as provided in the provisions of Sections 4.156.05, 4.156.07, 4.156.09, and 4.156.10.*
- H. *Temporary buildings for uses incidental to construction work, which buildings shall be removed upon completion or abandonment of the construction work.*
- I. *Accessory buildings and uses shall conform to front and side yard setback requirements. If the accessory buildings and uses do not exceed 120 square feet or ten feet in height, and they are detached and located behind the rear-most line of the main buildings, the side and rear yard setbacks may be reduced to three feet.*
- J. *Livestock and farm animals, subject to the provisions of Section 4.162.*

Response: No accessory uses to the proposed detached and attached single-family dwelling units are requested at this time. It is possible that future homes may include accessory buildings, which would be reviewed at the time of building permit.

(.03) Permitted accessory uses for multiple-family dwelling units: [...]

Response: There are no multiple-family dwelling units proposed under this application. The criterion is not applicable.

[...]

(.05) Appropriate PDR zone based on Comprehensive Plan Density:

Table 2 Density Requirements for PDR Zones

Zoning Designation	Comprehensive Plan Map Density Range District ^a	Max. Density per Acre ^{b, c}	Min. Density per Acre ^d
PDR-1	0-1	1	.8
PDR-2	2-3	3	2.4

Zoning Designation	Comprehensive Plan Map Density Range District ^a	Max. Density per Acre ^{b, c}	Min. Density per Acre ^d
PDR-3	4-5	5	4
PDR-4	6-7	7.5	6
PDR-5	10-12	12	9.6
PDR-6	16-20	20	16
PDR-7	Over 20	As approved by Zoning Order/Stage 1 Master Plan, at least 25	80% of Max Density

Response: The Comprehensive Plan Designation of Residential Neighborhood is implemented by the Residential Neighborhood RN zone. The RN zoning district is not included in the table above.

(.06) *Unit Count Limitations. Unit count limitations are calculated as follows:*

- A. *Maximum Unit Count. Maximum unit count at build out of Stage I Master Plan area: is calculated by taking the Gross Development Area multiplied by Maximum Density per Acre stated in Table 1 of this Code section, plus any density transferred from SROZ areas pursuant to Subsection 4.139.11(.02). For example, any number greater than four and less than five shall be rounded down to four.*
- B. *Minimum Unit Count. Minimum unit count at build out of Stage I Master Plan area: 80% of maximum unit count described in A. above.*
- C. *If the Stage I Master Plan area is subject to more than one Comprehensive Plan Map Density Range District and Zoning Designation, calculations for areas of differing densities shall be done separately and then summed together, and the final summed number rounded down to the nearest whole number.*

Response: The Comprehensive Plan Designation of Residential Neighborhood is implemented by the Residential Neighborhood RN zone and the density standards of the Frog Pond West Master Plan and Section 4.127.

(.07) *Lot Standards*

- A. *For townhouses the minimum lot size in PDR-1 through PDR-5 zones is 1,500 square feet.*
- B. *For the PDR 3 through PDR 7 zones, the minimum lot size for triplexes and three-unit cluster housing is 5,000 square feet; the minimum lot size for quadplexes, four-unit cluster housing, and cottage clusters is 7,000 square feet.*
- C. *A building must be completely detached from the largest building to be considered a separate building for the purpose of lot coverage calculations. Cottage clusters are exempt from maximum lot coverage standards.*
- D. *Lot frontage may be on a public street or approved, platted private drive.*
- E. *For townhouses the minimum lot width at building line and minimum street frontage is 20 feet in all PDR zones.*
- F. *Lot frontage may be reduced to 24 feet when the lot fronts a cul-de-sac.*

Response: The Comprehensive Plan Designation of Residential Neighborhood is implemented by the Residential Neighborhood RN zone and the lot size requirements of 4.127.

(.08) *Adjustments to Ensure Minimum Density is Met. In development not involving Multi-Family Dwelling Units, if demonstrated by the applicant that it is not physically possible to*

accommodate the minimum number of units at the required minimum lot size and the minimum open space, the following adjustments, A.—B., shall be made to the minimum extent necessary to enable minimum density to be met. To prioritize the provision of required open space, adjustments to minimum lot size, width, and depth shall be used to the extent allowed, as described in A. below, prior to any adjustment to open space requirements as described in B. below.

- A. *Adjustments to Minimum Lot Size, Width, and Depth: Reduce minimum lot size of up to 20% of the residential lots, rounded consistent with Subsection (.06) above or one lot for a four-lot subdivision, by up to 20%. For example, the potential adjustment, if determined necessary, for a 100-lot subdivision in the PDR-4 zone would be to reduce 20 lots to as low as 2,400 square feet (a 20% reduction of the 3,000 square foot minimum lot size). Also reduce the minimum lot width and minimum lot depth by up to 20% as necessary to allow the reduction of lot size.*
- B. *Adjustment to Open Space Area. Reduce the amount of open space area required pursuant to Subsection 4.113(.01). Reduce non-usable open space to the extent possible prior to usable open space required by Subsection 4.113(.01)C.3. After any adjustment to open space, all subdivisions with ten or more units must still include a minimum of one usable, programmed open space of at least 2,000 square feet meeting the requirements of Subsection 4.113(.01)C.3. Subdivisions less than ten units shall require one usable open space of at least 1,000 square feet meeting the same requirements.*

Response: The Comprehensive Plan Designation of Residential Neighborhood is implemented by the Residential Neighborhood RN zone and the density standards of 4.127.

(.09) Block and access standards:

1. *Maximum block perimeter in new land divisions: 1,800 feet.*
2. *Maximum spacing between streets or private drives for local access: 530 feet, unless waived by the Development Review Board upon finding that barriers such as railroads, freeways, existing buildings, topographic variations, or designated Significant Resource Overlay Zone areas will prevent street extensions meeting this standard.*
3. *Maximum block length without pedestrian and bicycle crossing: 330 feet, unless waived by the Development Review Board upon finding that barriers such as railroads, freeways, existing buildings, topographic variations, or designated Significant Resource Overlay Zone areas will prevent pedestrian and bicycle facility extensions meeting this standard.*

Response: As shown in Sheets C1.00 and C1.40, proposed SW Windflower Street, is placed to directly meet the Street Demonstration Plan in the Frog Pond West Master Plan. Its placement is located approximately 462 ft. from the Street Demonstration Plan's future street located on the property to the east. The block length is well below the maximum 1,800 ft. required by this section. This standard is met. SW Windflower Street is a local street with pedestrian crossing where it connects to Frog Pond Lane.

[...]

E. Section 4.127. Residential Neighborhood (RN) Zone.

(.01) Purpose. *The Residential Neighborhood (RN) zone applies to lands within Residential Neighborhood Comprehensive Plan Map designation. The RN zone is a Planned Development zone, subject to applicable Planned Development regulations, except as superseded by this section or in legislative master plans. The purposes of the RN Zone are to:*

- A. *Implement the Residential Neighborhood policies and implementation measures of the*

Comprehensive Plan.

- B. Implement legislative master plans for areas within the Residential Neighborhood Comprehensive Plan Map designation.*
- C. Create attractive and connected neighborhoods in Wilsonville.*
- D. Regulate and coordinate development to result in cohesive neighborhoods that include: walkable and active streets; a variety of housing appropriate to each neighborhood; connected paths and open spaces; parks and other non-residential uses that are focal points for the community; and, connections to and integration with the larger Wilsonville community.*
- E. Encourage and require quality architectural and community design as defined by the Comprehensive Plan and applicable legislative master plans.*
- F. Provide transportation choices, including active transportation options.*
- G. Preserve and enhance natural resources so that they are an asset to the neighborhoods, and there is visual and physical access to nature.*
- H. Create housing opportunities for a variety of households, including housing types that implement the Wilsonville Equitable Housing Strategic Plan and housing affordability provisions of legislative master plans.*

Response: Per Figure 5 of the Frog Pond West Master Plan (below), the Frog Pond Overlook site is located within the RN Comprehensive Plan Map designation and is subject to these provisions and to applicable Planned Development regulations of Section 4.118.

Figure 5. Comprehensive Plan Designations

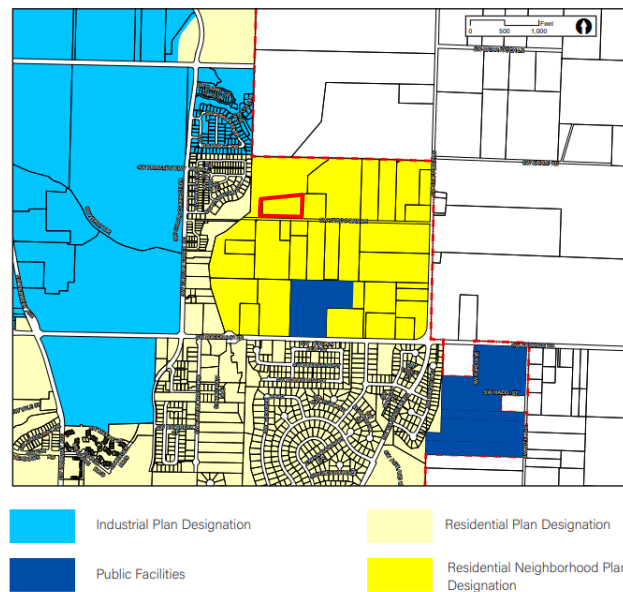

(.02) Permitted uses:

- A. Open Space.*
- B. Single-Family Dwelling Unit.*
- C. Attached Single-Family Dwelling Unit. In the Frog Pond West Neighborhood, a maximum of 2 dwelling units, not including ADU's [sic], may be attached.*
- D. Duplex.*
- E. Multiple-Family Dwelling Units, except when not permitted in a legislative master plan, subject to the density standards of the zone. Multi-family dwelling units are not permitted within the Frog Pond West Master Plan area.*

- F. Cohousing.
- G. Cluster Housing.
- H. Public or private parks, playgrounds, recreational and community buildings and grounds, tennis courts, and similar recreational uses, all of a non-commercial nature, provided that any principal building or public swimming pool shall be located not less than forty-five (45) feet from any other lot.
- I. Manufactured homes.
- J. Public or private parks, playgrounds, recreational and community buildings and grounds, tennis courts, and similar recreational uses, all of a non-commercial nature, provided that any principal building or public swimming pool shall be located not less than 45 feet from any other lot.
- K. Manufactured homes.

Response: As shown on Sheet C1.10, the proposed development includes 24 middle housing units, a 44,694 sq. ft. recreational area/open space in Tract A and a 1,599 sq. ft. private access/emergency turn-around area in Tract B. Both detached and attached single-family dwelling units are proposed for the newly created lots. None of the proposed lots are anticipated to exceed one dwelling unit. Standard has been met.

(.03) Permitted accessory uses to single family dwellings:

- A. Accessory uses, buildings and structures customarily incidental to any of the principal permitted uses listed above and located on the same lot.
- B. Living quarters without kitchen facilities for persons employed on the premises or for guests. Such facilities shall not be rented or otherwise used as a separate dwelling unless approved as an accessory dwelling unit or duplex.
- C. Accessory Dwelling Units, subject to the standards of Section 4.113 (.10).
- D. Home occupations.
- E. A private garage or parking area.
- F. Keeping of not more than two (2) roomers or boarders by a resident family.
- G. Temporary buildings for uses incidental to construction work, which buildings shall be removed upon completion or abandonment of the construction work.
- H. Accessory buildings and uses shall conform to front and side yard setback requirements. If the accessory buildings and uses do not exceed 120 square feet or ten (10) feet in height, and they are detached and located behind the rear-most line of the main buildings, the side and rear yard setbacks may be reduced to three (3) feet.
- I. Livestock and farm animals, subject to the provisions of Section 4.162.

Response: No accessory uses are proposed at this time.

(.04) Uses permitted subject to Conditional Use Permit requirements:

- A. Public and semi-public buildings and/or structures essential to the physical and economic welfare of an area, such as fire stations, sub-stations and pump stations.
- B. Commercial Recreation, including public or private clubs, lodges or meeting halls, golf courses, driving ranges, tennis clubs, community centers and similar commercial recreational uses. Commercial Recreation will be permitted upon a finding that it is compatible with the surrounding residential uses and promotes the creation of an attractive, healthful, efficient and stable environment for living, shopping or working. All such uses except golf courses and tennis courts shall conform to the requirements of Section 4.124(.04)(D) (Neighborhood Commercial Centers).
- C. Churches; public, private and parochial schools; public libraries and public museums.
- D. Neighborhood Commercial Centers limited to the provisions of goods and services primarily for the convenience of and supported by local residents. Neighborhood

Commercial Centers are only permitted where designated on an approved legislative master plan.

Response: No Conditional Uses are proposed.

(.05) Residential Neighborhood Zone Sub-districts:

A. *RN Zone sub-districts may be established to provide area-specific regulations that implement legislative master plans.*

1. *For the Frog Pond West Neighborhood, the sub-districts are listed in Table 1 of this code and mapped on Figure 6 of the Frog Pond West Master Plan. The Frog Pond West Master Plan Sub-District Map serves as the official sub-district map for the Frog Pond West Neighborhood.*

Response: The Frog Pond Overlook site is located within the Frog Pond West neighborhood and includes properties within Subdistrict 8 as shown in Figure 6 of the Frog Pond West Master Plan (below) and in Table 1 above. The site contains a small area of SROZ.

(.06) Minimum and Maximum Residential Lots:

- A. *The minimum and maximum number of residential units approved shall be consistent with this code and applicable provisions of an approved legislative master plan.*
1. *For initial development of the Frog Pond West Neighborhood, Table 1 in this Code and Frog Pond West Master Plan Table 1 establish the minimum and maximum number of residential lots for the sub-districts.*
 2. *For areas that are a portion of a sub-district, the minimum and maximum number of residential lots are established by determining the proportional gross acreage and applying that proportion to the minimums and maximums listed in Table 1. The maximum density of the area may be increased, up to a maximum of 10% of what would otherwise be permitted, based on an adjustment to an SROZ boundary that is consistent with 4.139.06.*

Response: DB22-0002 Frog Pond Overlook received a recommendation of approved by DRB (resolution 407) and subsequently was approved by CC (Ordinance 868), included the following approvals demonstrating compliance with the above requirements:

- Annexation (ANNX22-0001)
- Zone Map Amendment (ZONE22-0002)
- Stage 1 Preliminary Plan (STG122-0002)
- Stage 2 Final Plan (STG222-0002)
- Site Design Review of Parks and Open Space (SDR22-0002)
- Tentative Subdivision Plat (SUBD22-0001)
- Type C Tree Removal Plan (TPLN22-0001)
- Abbreviated SROZ Map Verification (SROZ22-0004)

The above land use decisions approved the Frog Pond Overlook development for 12-lots. House Bill 2001 (HB2001) requires middle housing types (with the exceptions of row houses) to be exempt from density limitations therefore the proposed 24 middle housing units are acceptable per code and HB2001 standards. Standards are met.

- B. *The City may allow a reduction in the minimum density for a sub-district when it is demonstrated that the reduction is necessary due to topography, protection of trees, wetlands and other natural resources, constraints posed by existing development, infrastructure needs, provision of non-residential uses and similar physical conditions.*

Response: No reduction to density standards is requested.

(.07) Development Standards Generally

- A. *Unless otherwise specified by this the regulations in this Residential Development Zone chapter, all development must comply with Section 4.113, Standards Applying to Residential Development in Any Zone.*

Response: Compliance with applicable regulations of Section 4.113 is addressed in Section III.B of this narrative. Some regulations of 4.127 supersede the regulations of 4.113.

(.08) Lot Development Standards:

- A. *Lot development shall be consistent with this Code and applicable provisions of an approved legislative master plan.*
- B. *Lot Standards Generally. For the Frog Pond West Neighborhood, Table 2 establishes the lot development standards unless superseded or supplemented by other provisions of the Development Code.*

C. *Lot Standards for Small Lot Sub-districts. The purpose of these standards is to ensure that development in the Small Lot Sub-districts includes varied design that avoids homogenous street frontages, creates active pedestrian street frontages and has open space that is integrated into the development pattern.*

Standards. Planned developments in the Small Lot Sub-districts shall include one or more of the following elements on each block:

1. *Alleys.*
2. *Residential main entries grouped around a common green or entry courtyard (e.g. cluster housing).*
3. *Four or more residential main entries facing a pedestrian connection allowed by an applicable legislative master plan.*
4. *Garages recessed at least four feet from the front façade or six feet from the front of a front porch.*

Response: Table 3 of the Frog Pond Master Plan establishes the following lot development standards for the Frog Pond West neighborhood. These standards supersede the setback standards of 4.113(.03). Lot dimensional standards are applied at the time of subdivision approval, while site development standards (setbacks, height, etc.) are applied at the time of building permit review. This proposal does not include the development of single-family homes or accessory structures. As shown in Table 3 below, the proposed lots meet the relevant standards.

Table 3 Compliance with Frog Pond West Neighborhood Lot Standards

Standard	Required	Proposed	Comments
	R-10 Large Lot		
Min Lot Size	8,000 sf	8,039-9,145 sf	Meets standards
Max Lot Coverage	40%	TBD	TBD at development
Max. Building Height	35 ft	TBD	TBD at development
Min Lot Depth*	60 ft.	63.25- 162.43 – ft.	Meets standards.
Min Lot Width**	40 ft	54-121.17 ft.	Meets standards

**Lot Depth:* The lot depth is the mean average distance between the front lot line and rear lot line of a lot measured within the lot boundaries.

** *Lot, Width:* The 'lot width' is the mean horizontal distance between the side lot lines of a lot measured within the lot boundaries.

D. *Lot Standards Specific to the Frog Pond West Neighborhood.*

1. *Lots adjacent to Boeckman Road and Stafford Road shall meet the following standards:*
 - a. *Rear or side yards adjacent to Boeckman Road and Stafford Road shall provide a wall and landscaping consistent with the standards in Figure 10 of the Frog Pond West Master Plan.*

Response: The subject property does not abut Stafford Road or Boeckman Road. This standard is not applicable.

2. *Lots adjacent to the collector-designated portions of Willow Creek Drive and Frog Pond Lane shall not have driveways accessing lots from these streets, unless no*

practical alternative exists for access. Lots in Large Lot Sub-districts are exempt from this standard.

Response: The proposed lots are large lots, and no portions of the subject property abut SW Willow Creek Drive and no portions of the property abut Collector designated portions of SW Frog Pond Lane. SW Frog Pond Lane abuts the property adjacent to proposed Lots 1-6 and 19-24, where it is designated as a Local street. This standard is not applicable.

(.09) Open Space:

- A. *Purpose. The purposes of these standards for the Residential Neighborhood Zone are to:*
- 1. Provide light, air, open space, and useable recreation facilities to occupants of each residential development.*
 - 2. Retain and incorporate natural resources and trees as part of developments.*
 - 3. Provide access and connections to trails and adjacent open space areas.*
For Neighborhood Zones which are subject to adopted legislative master plans, the standards work in combination with, and as a supplement to, the park and open space recommendations of those legislative master plans. These standards supersede the Open Space requirements in WC Section 4.113(.01).
- B. *Within the Frog Pond West Neighborhood, the following standards apply:*
- 1. Properties within the R-10 Large Lot sub-districts and R-7 Medium Lot sub-districts are exempt from the requirements of this section. If the Development Review Board finds, based upon substantial evidence in the record, that there is a need for open space, they may waive this exemption and require open space proportional to the need.*

Response: As shown in Figure 6 of the Frog Pond West Master Plan, the site is in Subdistrict 8 (R10) and is therefore exempt from open space requirements of this section.

- 2. For properties within the R-5 Small Lot Single Family sub-districts, Open Space Area shall be provided in the following manner:*
[...]

Response: As shown in Figure 6 of the Frog Pond West Master Plan, the site is in the Subdistrict 8 (R10). Small lot open space provisions are not applicable.

(.10) Block, access and connectivity standards:

- A. *Purpose. These standards are intended to regulate and guide development to create: a cohesive and connected pattern of streets, pedestrian connections and bicycle routes; safe, direct and convenient routes to schools and other community destinations; and, neighborhoods that support active transportation and Safe Routes to Schools.*
- B. *Blocks, access and connectivity shall comply with adopted legislative master plans.*
- 1. Within the Frog Pond West Neighborhood, streets shall be consistent with Figure 18, Street Demonstration Plan, in the Frog Pond West Master Plan. The Street Demonstration Plan is intended to be guiding, not binding. Variations from the Street Demonstration Plan may be approved by the Development Review Board, upon finding that one or more of the following justify the variation: barriers such as existing buildings and topography; designated Significant Resource Overlay Zone areas; tree groves, wetlands or other natural resources; existing or planned parks and other active open space that will serve as pedestrian connections for the public; alignment with property lines and ownerships that result in efficient use of land while providing*

substantially equivalent connectivity for the public; and/or site design that provides substantially equivalent connectivity for the public.

Response: The development proposes SW Windflower Street to be constructed north from Frog Pond Lane before curving east where it stubs for future development of the site to the east. Street A conforms directly with the Frog Pond West Master Plan Street Demonstration Plan. The overall development includes an extension of the Boeckman Creek Trail, which extends through the recreational area of Tract A and meets SW Windflower Street between middle housing unit 10 and proposed Tract B. There is also a short trail in Tract B that extends to an overlook with recreation amenities.

Submitted plans show a pedestrian connection between Frog Pond Lane and the location of SW Windflower Street. The estimated location of this connection is only approximately 150 ft. from the right-of-way of SW Windflower Street. A portion of the site is not able to be developed with residential lots due to the presence of the SROZ's impact zone. Due to the development limitations because of this area, the trail/pedestrian connections the applicant is proposing on the site, and the proximity of adjacent pedestrian connections, the applicant requests to not further reduce the number of lots available to construct this site.

2. *If a legislative master plan does not provide sufficient guidance for a specific development or situation, the Development Review Board shall use the block and access standards in Section 4.124(.06) as the applicable standards.*

Response: As illustrated by Figure 18 below, The Frog Pond West Master Plan provides guidance for block length, access, and connectivity. Additionally, Section 4.124 is addressed in Section III of this narrative.

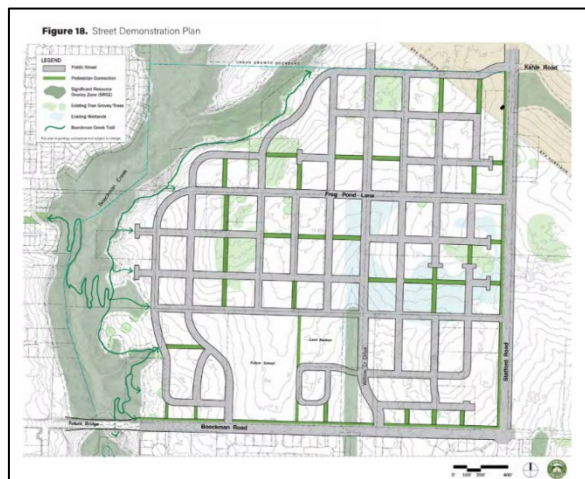

[...]

(.011) Signs. *Per the requirements of Sections 4.156.01 through 4.156.11 and applicable provisions from adopted legislative master plans.*

Response: The requirements of Sections 4.156.01 through 4.156.11 are addressed in Section IV.C of this narrative.

(.012) Parking. *Per the requirements of Section 4.155 and applicable provisions from adopted legislative master plans.*

Response: The requirements of Section 4.155 are addressed in Section IV.B of this narrative. The adopted legislative master plan applicable to this site is the Frog Pond West Master Plan, which has been codified in the zoning ordinance.

(.013) Corner Vision Clearance. *Per the requirements of Section 4.177.*

Response: The requirements of Section 4.177 are addressed in Section IV of this narrative.

(.014) Main Entrance Standards

- A. *Purpose. These standards:*
 - 1. *Support a physical and visual connection between the living area of the residence and the street;*
 - 2. *Enhance public safety for residents and visitors and provide opportunities for community interaction;*
 - 3. *Ensure that the pedestrian entrance is visible or clearly identifiable from the street by its orientation or articulation; and*
 - 4. *Ensure a connection to the public realm for development on lots fronting both private and public streets by making the pedestrian entrance visible or clearly identifiable from the public street.*
- B. *Location. At least one main entrance for each structure must:*
 - 1. *Be within 12 feet of the longest street-facing front wall of the dwelling unit; and*
 - 2. *Either:*
 - a. *Face the street*
 - b. *Be at an angle of up to 45 degrees from the street; or*
 - c. *Open onto a porch. The porch must:*
 - (i) *Be at least 6 feet deep*
 - (ii) *Have at least one entrance facing the street; and*
 - (iii) *Be covered with a roof or trellis*
- C. *Distance from grade. Main entrances meeting the standards in subsection B., above, must be within four feet of grade. For the purposes of this Subsection, grade is the average grade measured along the foundation of the longest street-facing wall of the dwelling unit.*

Response: The individual dwelling designs will be reviewed at the time of building permit submittal.

(.015) Garage Standards

- A. *Purpose. These standards:*
 - 1. *Ensure that there is a physical and visual connection between the living area of the residences and the street;*
 - 2. *Ensure that the location and amount of the living area of the residence, as seen from the street, is more prominent than garages;*
 - 3. *Prevent garages from obscuring the main entrance from the street and ensure that the main entrance for pedestrians, rather than automobiles, is the prominent entrance;*
 - 4. *Provide for a pleasant pedestrian environment by preventing garages and vehicle areas from dominating the views of the neighborhood from the sidewalk; and*
 - 5. *Enhance public safety by preventing garages from blocking views of the street from inside the residence.*
- B. *Street-Facing Garage Walls*

1. *Where these regulations apply. Unless exempted, the regulations of this subsection apply to garages accessory to residential units.*
2. *Exemptions:*
 - a. *Garages on flag lots.*
 - b. *Development on lots which slope up or down from the street with an average slope of 20% or more.*
3. *Standards.*
 - a. *The length of the garage wall facing the street may be up to 50% of the length of the street-facing building façade. For middle housing, this standard applies to the total length of the street-facing façades. For detached single-family and accessory structures, the standards apply to the street-facing façade of each unit. For corner lots, this standard applies to only one street side of the lot. For lots less than 50 feet wide at the front lot line, the standard in (b) below applies.*
 - b. *For lots less than 50 wide at the front lot line, the following standards apply:*
 - (i) *The width of the garage door may be up to 50% of the length of the street-facing façade.*
 - (ii) *The garage door must be recessed at least four feet from the front façade or six feet from the front of a front porch.*
 - (iii) *The maximum driveway width is 18 feet.*
 - c. *Where a dwelling abuts a rear or side alley or a shared driveway, the garage shall orient to the alley or shared drive.*
 - d. *Where three or more contiguous garage parking bays are proposed facing the same street, the garage opening closest to a side property line shall be recessed at least two feet behind the adjacent opening(s) to break up the street facing elevation and diminish the appearance of the garage from the street. Side-loaded garages, i.e., where the garage openings are turned away from the street, are exempt from this requirement.*
 - e. *A garage entry that faces a street may be no closer to the street than the longest street facing wall of the dwelling unit. There must be at least 20 feet between the garage door and the sidewalk. This standard does not apply to garage entries that do not face the street.*

Response: As shown on Sheets C1.10 and C1.40, there are no proposed alleys. All proposed lots will be accessed from local streets. The individual dwelling designs will be reviewed at the time of building permit submittal.

(0.16) Residential Design Standards

- A. *Purpose. These standards:*
 1. *Support consistent quality standards so that each home contributes to the quality and cohesion of the larger neighborhood and community.*
 2. *Support the creation of architecturally varied structures, blocks and neighborhoods, whether a neighborhood develops all at once or one lot at a time, avoiding homogeneous street frontages that detract from the community's appearance.*
- B. *Applicability. These standards apply to all façades facing streets, pedestrian connections, parks, open space tracts, the Boeckman Trail, or elsewhere as required by this Code or the Development Review Board. Exemptions from these standards include: (1) Additions or alterations adding less than 50% to the existing floor area of the structure; and, (2) Additions or alterations not facing a street, pedestrian connection, park, or open space tract.*

Response: All proposed dwelling façades will face streets or pedestrian connections and are subject to these standards, as well as the Design Standards for Detached Single-family and Middle Housing set forth within Section 4.113.14 of the development code. The individual dwelling designs will be reviewed at the time of building permit submittal.

- C. *Windows. The standards for minimum percentage of façade surface area in windows are below. These standards apply only to facades facing streets, pedestrian connections, parks, and open space tracts.*
1. *For two-story structures:*
 - a. *15% front facades.*
 - b. *12.5%—front facades if a minimum of six design elements are provided per Section 4.127(0.15)E., Design Menu.*
 - c. *10%—front facades facing streets if a minimum of seven design elements are provided per Section 4.127(0.15)E., Design Menu.*
 2. *For one-story structures:*
 - a. *12.5%—front facades.*
 - b. *10%—front facades if a minimum of six design elements are provided per Section 4.127(0.15)E., Design Menu.*
 3. *For all structures: Five percent for street-side facades.*
 4. *Windows used to meet this standard must provide views from the building to the street. Glass block does not meet this standard. Windows in garage doors and other doors count toward this standard.*
 5. *Street-facing facades along Boeckman Road and Stafford Road must meet the standards for front facades.*

Response: The individual dwelling designs will be reviewed at the time of building permit submittal.

- D. *Articulation. Plans for residential buildings shall incorporate design features such as varying rooflines, offsets, balconies, projections (e.g., overhangs, porches, or similar features), recessed or covered entrances, window reveals, or similar elements that break up otherwise long, uninterrupted elevations. Such elements shall occur at a minimum interval of 30 feet on façades facing streets, pedestrian connections, parks, open space tracts, or elsewhere as required by this Code or the Development Review Board. Where a façade governed by this standard is less than 30 feet in length, at least one of the above-cited features shall be provided.*

Response: The individual dwelling designs will be reviewed at the time of building permit submittal.

- E. *Residential Design Menu. Residential structures shall provide a minimum of five of the design elements listed below for front façades and façades facing Boeckman Road and Stafford Road, unless otherwise specified by the code. For side façades facing streets, pedestrian connections, parks, open space tracts, a minimum of three of the design elements must be provided. Where a design feature includes more than one element, it is counted as only one of the five required elements.*
1. *Dormers at least three feet wide.*
 2. *Covered porch entry—minimum 48 square foot covered front porch, minimum six feet deep and minimum of a six foot deep cover. A covered front stoop with minimum 24 square foot area, four foot depth and hand rails meets this standard.*
 3. *Front porch railing around at least two sides of the porch.*

4. *Front facing second story balcony - projecting from the wall of the building a minimum of four feet and enclosed by a railing or parapet wall.*
5. *Roof overhang of 16 inches or greater.*
6. *Columns, pillars or posts at least four inches wide and containing larger base materials.*
7. *Decorative gables - cross or diagonal bracing, shingles, trim, corbels, exposed rafter ends or brackets (does not include a garage gable if garage projects beyond dwelling unit portion of street façade).*
8. *Decorative molding above windows and doors.*
9. *Decorative pilaster or chimneys.*
10. *Shakes, shingles, brick, stone or other similar decorative materials occupying at least 60 square feet of the street façade.*
11. *Bay or bow windows - extending a minimum of 12 inches outward from the main wall of a building and forming a bay or alcove in a room within the building.*
12. *Sidelight and/or transom windows associated with the front door or windows in the front door.*
13. *Window grids on all façade windows (excluding any windows in the garage door or front door).*
14. *Maximum nine foot wide garage doors or a garage door designed to resemble two smaller garage doors and/or windows in the garage door (only applicable to street facing garages).*
15. *Decorative base materials such as natural stone, cultured stone or brick extending at least 36 inches above adjacent finished grade occupying a minimum of 10% of the overall primary street facing façade.*
16. *Entry courtyards which are visible from, and connected directly to, the street. Courtyards shall have a minimum depth of ten feet and minimum width of 80% of the non-garage/driveway building width to be counted as a design element.*

Response: Each of the proposed detached residential structures will demonstrate compliance with the residential design menu at the time of building permit submittal.

- F. House Plan Variety. No two directly adjacent or opposite residential structures may possess the same front or street-facing elevation. A structure containing multiple middle housing units shall be considered a single residential structure for the purpose of house plan variety. This standard is met when front or street-facing elevations differ from one another due to different materials, articulation, roof type, inclusion of a porch, fenestration, and/or number of stories. Where façades repeat on the same block face, they must have at least three intervening residential structures between them that meet the above standard. Small Lot developments over ten acres shall include duplexes and/or two-unit townhouses comprising 10% of the homes—corner locations are preferred.*

Response: The submission associated with the DRB's approved Resolution 407 included examples of home designs. Multiple detached dwelling types were provided, and they will not be repeated on adjacent or opposite lots along the same street frontage. This standard will be verified at the time of building permit submittal.

- G. Prohibited Building Materials. The following construction materials may not be used as an exterior finish:*
1. *Vinyl siding.*
 2. *Wood fiber hardboard siding.*
 3. *Oriented strand board siding.*
 4. *Corrugated or ribbed metal.*

5. *Fiberglass panels.*

Response: Prohibited materials are acknowledged and no prohibited building materials shall be proposed. Conformance with these standards will be verified at the time of building permit submittal.

(0.17) Fences

A. *Within Frog Pond West, fences shall comply with standards in 4.113 (.08) except as follows:*

1. *Columns for the brick wall along Boeckman Road and Stafford Road shall be placed at lot corners where possible.*
2. *A solid fence taller than 4 feet in height is not permitted within 8 feet of the brick wall along Boeckman Road and Stafford Road, except for fences placed on the side lot line that are perpendicular to the brick wall and end at a column of the brick wall.*
3. *Height transitions for fences shall occur at fence posts.*

Response: The site is not located along Boeckman Rd or Stafford Rd, and no fences are proposed with this development.

(0.18) Residential Structures Adjacent to Schools, Parks and Public Open Spaces

A. *Purpose. The purpose of these standards is to ensure that development adjacent to schools and parks is designed to enhance those public spaces with quality design that emphasizes active and safe use by people and is not dominated by driveways, fences, garages, and parking.*

B. *Applicability. These standards apply to development that is adjacent to or faces schools and parks. As used here, the term adjacent includes development that is across a street or pedestrian connection from a school or park.*

Response: Lots 1-12 are adjacent to private open space Tract A, and lot 9 is also adjacent to private open space, Tract B. These lots are not subject to these standards. However, the applicant intends to create an attractive appearance for open space users.

C. *Development must utilize one or more of the following design elements:*

1. *Alley loaded garage access.*
2. *On corner lots, placement of the garage and driveway on the side street that does not face the school, park, or public open space.*
3. *Recess of the garage a minimum of four feet from the front façade of the home. A second story above the garage, with windows, is encouraged for this option.*

Response: As noted above, the subject lots are adjacent to private, rather than public, open space. These standards are not applicable but will be considered during home plan selection.

D. *Development must be oriented so that the fronts or sides of residential structures face adjacent schools or parks. Rear yards and rear fences may generally not face the schools or parks, unless approved through the waiver process of 4.118 upon a finding that there is no practicable alternative due to the size, shape or other physical constraint of the subject property.*

Response: None of the proposed lots face schools or public parks. As noted above, the subject lots are adjacent to private, rather than public, open space. These standards are not applicable but will be considered during home plan selection.

F. Section 4.139. Significant Resource Overlay Zone (SROZ) Ordinance.

[...]

Section 4.139.02 Where these Regulations Apply

The regulations of this Section apply to the portion of any lot or development site, which is within a Significant Resource Overlay Zone and its associated "Impact Areas". The text provisions of the Significant Resource Overlay Zone ordinance take precedence over the Significant Resource Overlay Zone maps. The Significant Resource Overlay Zone is described by boundary lines shown on the City of Wilsonville Significant Resource Overlay Zone Map. For the purpose of implementing the provisions of this Section, the Wilsonville Significant Resource Overlay Zone Map is used to determine whether a Significant Resource Impact Report (SRIR) is required. Through the development of an SRIR, a more specific determination can be made of possible impacts on the significant resources.

[...]

Response: Per the City's SROZ Map and Figure 6 of the Frog Pond West Master Plan, this site contains land that is within the SROZ overlay; therefore, this section applies. Though DB22-0002 Frog Pond Overlook received a recommendation of approval by the DBR (resolution 407) and subsequent approval from CC (Ordinance 868), an Abbreviated SROZ Map Verification (SROZ22-0004) was issued. The proposed middle housing land division will not affect any previous SROZ verified area mapped on the subject property.

Section 4.139.03 Administration

[...]

(.02) *Impact Area. The "Impact Area" is the area adjacent to the outer boundary of a Significant Resource within which development or other alteration activities may be permitted through the review of an SRIR (Significant Resource Impact Report). Where it can be clearly determined by the Planning Director that development is only in the Impact Area and there is no impact to the Significant Resource, development may be permitted without SRIR review. The impact area is 25 feet wide unless otherwise specified in this ordinance or by the decision making body. Designation of an Impact Area is required by Statewide Planning Goal 5. The primary purpose of the Impact Area is to ensure that development does not encroach into the SROZ.*

Response: DB22-0002 Frog Pond Overlook received a recommendation of approval by DRB (resolution 407) and was subsequently approved by CC (Ordinance 868), confirmed future development on the proposed residential lots will not occur within the Impact Area or the SROZ. The proposed revised middle housing land division will not change this finding.

(.03) *Significant Resource Impact Report (SRIR). For proposed non-exempt development within the SROZ, the applicant shall submit a Significant Resource Impact Report (SRIR) as part of any application for a development permit.*

Response: There is no development proposed within the SROZ or Impact Area. DB22-0002 Frog Pond Overlook, subsequently approved by DRB (resolution 407) and CC (Ordinance 868), confirmed the location of the SROZ and Impact Area (SROZ22-0004), therefore a SRIR is not required for the proposed development.

(.04) *Prohibited Activities. New structures, development and construction activities shall not be permitted within the SROZ if they will negatively impact significant natural resources. Gardens, lawns, application of chemicals, uncontained areas of hazardous materials as defined by DEQ, domestic animal waste, dumping of materials of any kind, or other*

activities shall not be permitted within the SROZ if they will negatively impact water quality.

Unauthorized land clearing or grading of a site to alter site conditions is not allowed, and may result in the maximum requirement of mitigation/enhancement regardless of pre-existing conditions.

Response: There is no development proposed within the SROZ or Impact Area.

- (.05) *Habitat-Friendly Development Practices.* To the extent practicable, development and construction activities that encroach within the Significant Resource Overlay Zone and/or Impact Area shall be designed, located and constructed to:
- A. Minimize grading, removal of native vegetation, disturbance and removal of native soils, and impervious area;
 - B. Minimize adverse hydrological impacts on water resources, such as using the practices described in Part (a) of Table NR-2, unless their use is prohibited by an applicable and required state or federal permit, such as a permit required under the federal Clean Water Act, 33 U.S.C. §§1251 et seq., or the federal Safe Drinking Water Act, 42 U.S.C. §§300f et seq., and including conditions or plans required by such permit;
 - C. Minimize impacts on wildlife corridors and fish passage, such as by using the practices described in Part (b) of Table NR-2; and
 - D. Consider using the practices described in Part (c) of Table NR-2.

Response: No development is proposed within the SROZ. Improving Frog Pond Lane and the construction of the Boeckman Creek Trail are outside of the SROZ and Impact Area.

Section 4.139.04 Uses and Activities Exempt from These Regulations

A request for exemption shall be consistent with the submittal requirements listed under Section 4.139.06(.01)(B – I), as applicable to the exempt use and activity. [Added by Ord. # 674 11/16/09]
[...]

- (.02) Maintenance and repair of buildings, structures, yards, gardens or other activities or uses that were in existence prior to the effective date of these regulations.
- (.03) Alterations of buildings or accessory structures which do not increase building coverage.
- (.05) Operation, maintenance, and repair of irrigation and drainage ditches, constructed ponds, wastewater facilities, stormwater detention or retention facilities, and water facilities consistent with the Stormwater Master Plan or the Comprehensive Plan.
- (.06) Maintenance and repair of streets and utility services within rights-of way, easements, access drives or other previously improved areas. [Amended by Ord. 682, 9/9/10]
- (.07) Normal and routine maintenance and repair of any public improvement or public recreational area regardless of its location.
- (.08) The construction of new roads, pedestrian or bike paths into the SROZ in order to provide access to the sensitive area or across the sensitive area, provided the location of the crossing is consistent with the intent of the Wilsonville Comprehensive Plan. Roads and paths shall be constructed so as to minimize and repair disturbance to existing vegetation and slope stability.
[...]
- (.10) The removal of invasive vegetation such as Himalayan Blackberry, English Ivy, Poison Oak, Scots (Scotch) Broom or as defined as invasive in the Metro Native Plant List.
- (.11) The planting or propagation of any plant identified as native on the Metro Native Plant List. See Wilsonville Planning Division to obtain a copy of this list.
- (.12) Grading for the purpose of enhancing the Significant Resource as approved by the City.

- (.13) *Enhancement of the riparian corridor or wetlands for water quality or quantity benefits, fish, or wildlife habitat as approved by the City and other appropriate regulatory authorities.*
- (.14) *Flood control activities pursuant to the Stormwater Master Plan, save and except those stormwater facilities subject to Class II Administrative Review, as determined by the Planning Director, to ensure such facilities meet applicable standards under federal, state and local laws, rules and regulations.*
- (.15) *Developments that propose a minor encroachment into the Significant Resource Overlay Zone. The purpose of this adjustment would be to allow for minor encroachments of impervious surfaces such as accessory buildings, eave overhangs, building appurtenances, building access and exiting requirements or other similar feature. The total adjustment shall not exceed 120 square feet in cumulative area.*
- [...]
- (.18) *Private or public service connection laterals and service utility extensions.*
- (.19) *A Stage II development permit or other development permits issued by the City and approved prior to the effective date of this ordinance.*
- (.20) *The installation of public streets and utilities specifically mapped within a municipal utility master plan, the Transportation Systems Plan or a capital improvement plan.*

Response: There is no development proposed within the SROZ or Impact Area. DB22-0002 Frog Pond Overlook, subsequently approved by DRB (resolution 407) and CC (Ordinance 868), confirmed the location of the SROZ and Impact Area.

Section 4.139.05 Significant Resource Overlay Zone Map Verification

The map verification requirements described in this Section shall be met at the time an applicant requests a building permit, grading permit, tree removal permit, land division approval, or other land use decision. Map verification shall not be used to dispute whether the mapped Significant Resource Overlay Zone boundary is a significant natural resource. Map refinements are subject to the requirements of Section 4.139.10(.01)(D).

- (.01) *In order to confirm the location of the Significant Resource Overlay Zone, map verification shall be required or allowed as follows:*
 - A. *Development that is proposed to be either in the Significant Resource Overlay Zone or less than 100 feet outside of the boundary of the Significant Resource Overlay Zone, as shown on the Significant Resource Overlay Zone Map.*
 - B. *A lot or parcel that:*
 - 1. *Either contains the Significant Resource Overlay Zone, or any part of which is less than 100 feet outside the boundary of the Significant Resource Overlay Zone, as shown on the Significant Resource Overlay Zone Map; and*
 - 2. *Is the subject of a land use application for a partition, subdivision, or any land use application that the approval of which would authorize new development on the subject lot or parcel.*

Response: This application includes a middle housing land division request that will adjust previously approved lots that are within 100 feet of the SROZ boundary. DB22-0002 Frog Pond Overlook, subsequently approved by DRB (resolution 407) and CC (Ordinance 868), verified the location of the SROZ and Impact Area, therefore map verification is not required for the proposed tentative plat revision.

- (.02) *An application for Significant Resource Overlay Zone Map Verification may be submitted even if one is not required pursuant to Section 4.139.05(.01).*
- (.03) *If a lot or parcel or parcel is subject to Section 4.139.05(.01), an application for Significant Resource Overlay Zone Map Verification shall be filed concurrently with the other land*

use applications referenced in Section 4.139.05(.01)(B)(2) unless a previously approved Significant Resource Overlay Zone Map Verification for the subject property remains valid.

Response: The site is subject to Section 4.139.05(.01) as noted above. DB22-0002 Frog Pond Overlook, subsequently approved by DRB (resolution 407) and CC (Ordinance 868), verified the location of the SROZ and Impact Area, therefore map verification is not required for the proposed tentative plat revision.

- (.04) *An applicant for Significant Resource Overlay Zone Map Verification shall use one or more of the following methods to verify the Significant Resource Overlay Zone boundary:*
- A. *The applicant may concur with the accuracy of the Significant Resource Overlay Zone Map of the subject property;*
 - B. *The applicant may demonstrate a mapping error was made in the creation of the Significant Resource Overlay Zone Map;*
 - C. *The applicant may demonstrate that the subject property was developed lawfully prior to June 7, 2001.*

Response: Findings presented in the Map Verification report associated with DB22-0002 Frog Pond Overlook, subsequently approved by DRB (resolution 407) and CC (Ordinance 868), demonstrate that the SROZ is slightly different than shown on existing City maps. Standard has been met via previous approval.

[...]

(.06) *For applications filed pursuant to Section 4.139.05(.04)(A) and (C), a Significant Resource Overlay Zone Map Verification shall be consistent with the submittal requirements listed under Section 4.139.06(.01)(B-H).*

Response: All required submittals established in 4.139.06(.01)(B-H) were submitted with the application associated with DB22-0002 Frog Pond Overlook received a recommendation of approval by DRB (resolution 407) and subsequently was approved by CC (Ordinance 868). Standard has been met via previous approval.

(.07) *For applications filed pursuant to Section 4.139.05(.04)(B), a Significant Resource Overlay Zone Map Verification shall be consistent with the submittal requirements listed under Section 4.139.06(.02)(D)(1).*

Response: All required submittal requirements established in Section 4.139.05(.04)(A) were submitted with the application associated with DB22-0002 Frog Pond Overlook received a recommendation of approval by DRB (resolution 407) and subsequently was approved by CC (Ordinance 868). Standard has been met via previous approval and is not required for the proposed revised tentative plat.

Section 4.139.06 Significant Resource Impact Report (SRIR) and Review Criteria

A Significant Resource Impact Report (SRIR) is a report that delineates specific resource boundaries and analyzes the impacts of development within mapped significant resource areas based upon the requirements of this Section. An SRIR is only required for non-exempt development that is located within the Significant Resource Overlay Zone and/or its associated 25-foot Impact Area.

- (.01) *Abbreviated SRIR Requirements. It is the intent of this subsection to provide a user-friendly process for the applicant. Only the materials necessary for the application review are required. At the discretion of the Planning Director, an abbreviated SRIR may be submitted for certain small-scale developments such as single-family dwellings, additions*

to single family dwellings, minor additions and accessory structures. The following requirements shall be prepared and submitted as part of the abbreviated SRIR evaluation:

- A. A Site Development Permit Application must be submitted in compliance with the Planning and Land Development Ordinance;*
- B. Outline of any existing features including, but not limited to, structures, decks, areas previously disturbed and existing utility locations*;*
- C. Location of any wetlands or water bodies on the site and the location of the stream centerline and top-of-bank;*
- D. Within the area proposed to be disturbed, the location, size and species of all trees that are more than six (6) inches in diameter at breast height (DBH). Trees outside the area proposed to be disturbed may be individually shown or shown as drip line with an indication of species type or types;*
- E. The location of the SROZ and Impact Area boundaries*;*
- F. A minimum of three slope cross-section measurements transecting the site, equally spaced at no more than 100-foot increments. The measurements should be made perpendicular to the stream*;*
- G. A map that delineates the Metro UGMFP Title 3 Water Quality Resource Area boundary (using Metro Title 3 field observed standards)*;*
- H. Current photos of site conditions shall be provided to supplement the above information*.*
- I. A narrative describing the possible and probable impacts to natural resources and a plan to mitigate for such impacts*.*

**Indicates information that City Staff may have readily available to assist an applicant.*

Response: DB22-0002 Frog Pond Overlook, recommended for approval by DRB (resolution 407) and CC (Ordinance 868), established the site contains mapped SROZ. DB22-0002 findings included the following statement, "The applicant conducted a detailed site analysis consistent with Development Code requirements, which the City's Natural Resources manager reviewed to verify the SROZ boundary. Per this verification, the SROZ". As such, no further analysis has been completed for the proposed middle housing land division.

Figure 6. Frog Pond West Land Use and Subdistricts

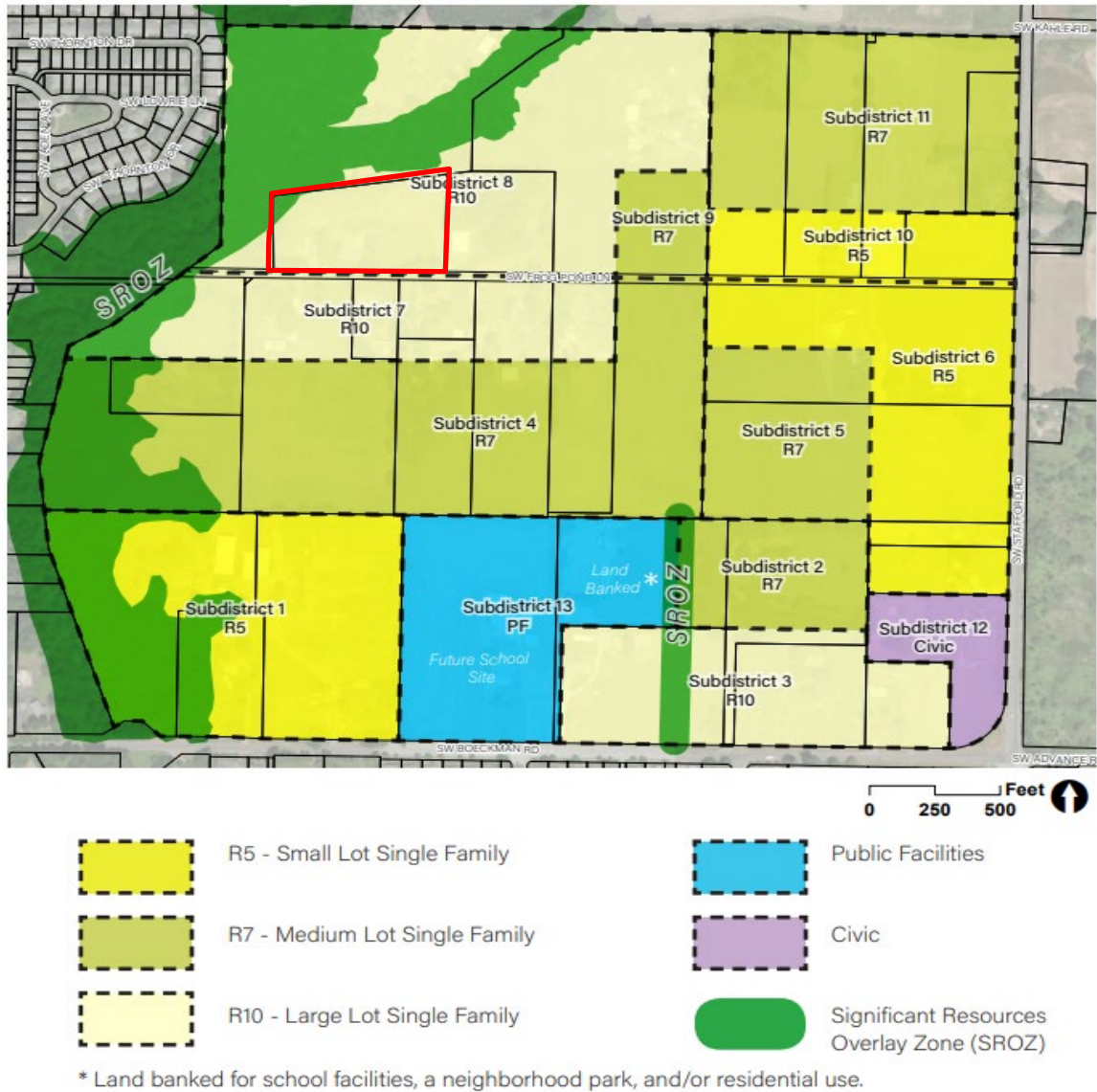

Section 4.139.07 Mitigation Standards

The following mitigation standards apply to significant wildlife habitat resource areas for encroachments within the Area of Limited Conflicting Uses, and shall be followed by those proposing such encroachments. Wetland mitigation shall be conducted as per permit conditions from the US Army Corps of Engineers and Oregon Division of State Lands. While impacts are generally not allowed in the riparian corridor resource area, permitted impacts shall be mitigated by: using these mitigation standards if the impacts are to wildlife habitat values; and using state and federal processes if the impacts are to wetland resources in the riparian corridor. Mitigation is not required for trees lost to a natural event such as wind or floods.[...]

Response: No development is occurring in the SROZ, Impact Area or Area of Limited Conflicting Uses.

G. Section 4.140. Planned Development Regulations.

(.01) Purpose.

- A. *The provisions of Section 4.140 shall be known as the Planned Development Regulations. The purposes of these regulations are to encourage the development of tracts of land sufficiently large to allow for comprehensive master planning, and to provide flexibility in the application of certain regulations in a manner consistent with the intent of the Comprehensive Plan and general provisions of the zoning regulations and to encourage a harmonious variety of uses through mixed use design within specific developments thereby promoting the economy of shared public services and facilities and a variety of complimentary activities consistent with the land use designation on the Comprehensive Plan and the creation of an attractive, healthful, efficient and stable environment for living, shopping or working.*
- B. *It is the further purpose of the following Section:*
 1. *To take advantage of advances in technology, architectural design, and functional land use design;*
 2. *To recognize the problems of population density, distribution and circulation and to allow a deviation from rigid established patterns of land uses, but controlled by defined policies and objectives detailed in the comprehensive plan;*
 3. *To produce a comprehensive development equal to or better than that resulting from traditional lot land use development.*
 4. *To permit flexibility of design in the placement and uses of buildings and open spaces, circulation facilities and off-street parking areas, and to more efficiently utilize potentials of sites characterized by special features of geography, topography, size or shape or characterized by problems of flood hazard, severe soil limitations, or other hazards;*
 5. *To permit flexibility in the height of buildings while maintaining a ratio of site area to dwelling units that is consistent with the densities established by the Comprehensive Plan and the intent of the Plan to provide open space, outdoor living area and buffering of low-density development.*
 6. *To allow development only where necessary and adequate services and facilities are available or provisions have been made to provide these services and facilities.*
 7. *To permit mixed uses where it can clearly be demonstrated to be of benefit to the users and can be shown to be consistent with the intent of the Comprehensive Plan.*
 8. *To allow flexibility and innovation in adapting to changes in the economic and technological climate.*

Response: This proposal includes middle housing land division to further divide the Frog Pond Overlook approved Tentative Subdivision Plat (SUBD22-0001) into a total of 24 middle housing

units. Specifically, the 12 lots of the Frog Pond Overlook revised tentative plat will be further divided to incorporate middle housing units for future development. The proposed development meets the standards established in the Frog Pond West Master Plan and the standards of this section.

(.02) Lot Qualification.

- A. *Planned Development may be established on lots which are suitable for and of a size to be planned and developed in a manner consistent with the purposes and objectives of Section 4.140.*
- B. *Any site designated for development in the Comprehensive Plan may be developed as a Planned Development, provided that it is zoned "PD" or specifically defined as a PD zone by this Code. All sites which are greater than two acres in size, and designated in the Comprehensive Plan for commercial, residential, or industrial use shall be developed as Planned Developments, unless approved for other uses permitted by the Development Code. Smaller sites may also be developed through the City's PD procedures, provided that the location, size, lot configuration, topography, open space and natural vegetation of the site warrant such development.*

Response: The subject site is 4.07 acres in area and is designated in the Comprehensive Plan for residential use. The proposed development will be developed as a residential Planned Development per the provisions of this section.

(.03) Ownership.

- A. *The tract or tracts of land included in a proposed Planned Development must be in one (1) ownership or control or the subject of a joint application by the owners of all the property included. The holder of a written option to purchase, with written authorization by the owner to make applications, shall be deemed the owner of such land for the purposes of Section 4.140.*
- B. *Unless otherwise provided as a condition for approval of a Planned Development permit, the permittee may divide and transfer units or parcels of any development. The transferee shall use and maintain each such unit or parcel in strict conformance with the approval permit and development plan.*

Response: The properties included in the proposed PD are under a single ownership.

(.04) Professional Design.

- A. *The applicant for all proposed Planned Developments shall certify that the professional services of the appropriate professionals have been utilized in the planning process for development.*
- B. *Appropriate professionals shall include, but not be limited to the following to provide the elements of the planning process set out in Section 4.139:*
 - 1. *An architect licensed by the State of Oregon;*
 - 2. *A landscape architect registered by the State of Oregon;*
 - 3. *An urban planner holding full membership in the American Institute of Certified Planners, or a professional planner with prior experience representing clients before the Development Review Board, Planning Commission, or City Council; or*
 - 4. *A registered engineer or a land surveyor licensed by the State of Oregon.*
- C. *One of the professional consultants chosen by the applicant from either 1, 2, or 3, above, shall be designated to be responsible for conferring with the planning staff with respect to the concept and details of the plan.*
- D. *The selection of the professional coordinator of the design team will not limit the owner or the developer in consulting with the planning staff.*

Response: The development team includes Mike Peebles, PE; Keith Buisman, PE; Rose Horton, PE; Steve Dixon, PLA; Gabriel Kruse, PLA; and James Cramer. James Cramer has been designated as the applicant's representative and party responsible for conferring with the planning staff.

(.05) Planned Development Permit Process.

- A. *All parcels of land exceeding two (2) acres in size that are to be used for residential, commercial or industrial development, shall, prior to the issuance of any building permit:*
1. *Be zoned for planned development;*
 2. *Obtain a planned development permit; and*
 3. *Obtain Development Review Board, or, on appeal, City Council approval.*

Response: The subject site exceeds 2 acres in size and is proposed for residential development. DB22-0002 Frog Pond Overlook, subsequently approved by DRB (resolution 407) and CC (Ordinance 868), included the following approvals demonstrating compliance with the above requirements:

- Annexation (ANNX22-0001)
- Zone Map Amendment (ZONE22-0002)
- Stage 1 Preliminary Plan (STG122-0002)
- Stage 2 Final Plan (STG222-0002)
- Site Design Review of Parks and Open Space (SDR22-0002)
- Tentative Subdivision Plat (SUBD22-0001)
- Type C Tree Removal Plan (TPLN22-0001)
- Abbreviated SROZ Map Verification (SROZ22-0004)

- B. *Zone change and amendment to the zoning map are governed by the applicable provisions of the Zoning Sections, inclusive of Section 4.197.*

Response: DB22-0002 Frog Pond Overlook, recommended for approval by DRB (resolution 407) and subsequently approved by CC (Ordinance 868), included a Zone Map Amendment (ZONE22-0002) approval. The proposed middle housing land division will not affect the findings of the Zone Map Amendment (ZONE22-0002) approval.

- C. *Development Review Board approval is governed by Sections 4.400 to 4.450*
- D. *All planned developments require a planned development permit. The planned development permit review and approval process consists of the following multiple stages, the last two or three of which can be combined at the request of the applicant:*
1. *Pre-application conference with Planning Department;*
 2. *Preliminary (Stage I) review by the Development Review Board. When a zone change is necessary, application for such change shall be made simultaneously with an application for preliminary approval to the Board; and*
 3. *Final (Stage II) review by the Development Review Board*
 4. *In the case of a zone change and zone boundary amendment, City Council approval is required to authorize a Stage I preliminary plan.*

Response: A pre-application conference was held with the Planning Department on September 16, 2021 for the submittal associated with DB22-0002 Frog Pond Overlook. An informal meeting was held February 27, 2023, with City staff to discuss the proposed revisions to the tentative plat and it was determined that a formal pre-application meeting was not necessary for the Class II middle housing land division review.

[...]

(.07) Preliminary Approval (Stage One):

- A. *Applications for preliminary approval for planned developments shall:*
- 1. Be made by the owner of all affected property or the owner's authorized agent; and*
 - 2. Be filed on a form prescribed by the City Planning Department and filed with said Department.*
 - 3. Set forth the professional coordinator and professional design team as provided in subsection (.04), above.*
 - 4. State whether the development will include mixed land uses, and if so, what uses and in what proportions and locations.*

Response: The proposed development received Stage 1 Preliminary Plan approval (STG122-0002) via DB22-0002 Frog Pond Overlook, recommended approval by DRB (resolution 407) and subsequent approval by CC (Ordinance 868). No additional approval is needed at this time in relation to the proposed revised tentative plat.

[...]

(.09) Final Approval (Stage Two):

[Note: Outline Number is incorrect.]

- A. *Unless an extension has been granted by the Development Review Board or Planning Director, as applicable, within two years after the approval or modified approval of a preliminary development plan (Stage I), the applicant shall file with the City Planning Department a final plan for the entire development or when submission in stages has been authorized pursuant to Section 4.035 for the first unit of the development, a public hearing shall be held on each such application as provided in Section 4.013. As provided in Section 4.134, an application for a Stage II approval within the Coffee Creek Industrial Design Overlay District may be considered by the Planning Director without a public hearing as a Class II Administrative Review as provided in Section 4.035(.03).*

Response: The proposed development received Stage 2 Final Plan approval (STG222-0002) via DB22-0002 Frog Pond Overlook, subsequently approved by DRB (resolution 407) and CC (Ordinance 868). No additional approval is needed at this time in relation to the proposed revised tentative plat.

[...]

(.10) Adherence to Approved Plans, Modification.

- A. *Adherence to Approved Plan and Modification Thereof: The applicant shall agree in writing to be bound, for her/himself and her/his successors in interest, by the conditions prescribed for approval of a development. The approved final plan and stage development schedule shall control the issuance of all building permits and shall restrict the nature, location and design of all uses. Minor changes in an approved preliminary or final development plan may be approved by the Director of Planning if such changes are consistent with the purposes and general character of the development plan. All other modifications, including extension or revision of the stage development schedule, shall be processed in the same manner as the original application and shall be subject to the same procedural requirements.*
- B. *In the event of a failure to comply with the approved plan or any prescribed condition of approval, including failure to comply with the stage development schedule, the Development Review Board may, after notice and hearing, revoke a Planned Development permit. General economic conditions that affect all in a similar manner may be considered as a basis for an extension of a development schedule. The determination*

of the Board shall become final 30 days after the date of decision unless appealed to the City Council.

- C. *Approved plans and non-conforming status with updated zoning and development standards.*
1. *Approved plans are the basis of legal conforming status of development except where one of the following occurs, at which point, the approved planned development becomes legally non-conforming:*
 - a. *the zoning of land within the plan area has been changed since adoption of the plan; or*
 - b. *the zoning standards for the zone under which it was approved have been substantially modified (50% or more of the regulatory standards have been modified as determined by the Planning Director); or*
 - c. *the City Council declared all planned developments in a certain zone or zones to be legal non-conforming as part of an ordinance to update or replace zoning standards; or*
 - d. *the City Council declared, by a stand-alone ordinance, planned developments in a certain zone not complying with current standards to be legal non-conforming. The City Council may, in an ordinance establishing non-conforming status of a planned development, declare the entire planned development to be non-conforming or declare certain standards established in the planned development to be non-conforming (i.e., lot coverage, setbacks, stormwater standards).*
 2. *If one of the conditions of subsection 1. is met, development that is consistent with the approved plan, but not complying with current zoning standards, shall be considered legal non-conforming and subject to the standards of Sections 4.189 thru 4.192.*
 3. *In no case shall a planned development approved within the previous 24 months, or under a time-extension under WC Section 4.023, be considered non-conforming; but automatically will become non-conforming after 24-months, and the end of any extensions, if it otherwise would qualify as legally non-conforming or is so declared pursuant to this subsection.*
- D. *The following are exempt from established residential density requirements beyond one unit per lot.*
1. *Accessory Dwelling Units.*
 2. *Duplexes.*
 3. *Triplexes.*
 4. *Quadplexes.*
 5. *Cluster housing.*
- E. *For new townhouses in existing residential planned developments in residential zones, the allowed density shall be the lesser of: (1) Four times the maximum net density for the lot(s) or parcel(s) established in the approved plan, or (2) 25 units per acre.*
- F. *Notwithstanding Subsection C. above, single-family residential development built consistent with an approved master plan in the Planned Development Commercial or Planned Development Industrial zones prior to November 18, 2021 shall continue to be legal conforming uses. However, all lots within these master plans that allow for detached single-family must also allow all middle housing types with density exemptions and allowances consistent with D. and E. above. In addition, any lot coverage maximums established in the master plans less than those listed in Table 2 of Subsection 4.124(.07) are superseded by lot coverage standards in that table.*

Response: The applicant intends to construct detached and attached single-family dwelling units within this development.

(.11) Early Vesting of Traffic Generation. [...]

Response: No early vesting of traffic generation is requested. This standard is not applicable.

4. General Development Regulations

A. Section 4.154. On-site Pedestrian Access and Circulation.

(.01) On-site Pedestrian Access and Circulation

- A. *The purpose of this section is to implement the pedestrian access and connectivity policies of the Transportation System Plan. It is intended to provide for safe, reasonably direct, and convenient pedestrian access and circulation.*
- B. *Standards. Development shall conform to all of the following standards:*
 - 1. *Continuous Pathway System. A pedestrian pathway system shall extend throughout the development site and connect to adjacent sidewalks, and to all future phases of the development, as applicable.*
 - 2. *Safe, Direct, and Convenient. Pathways within developments shall provide safe, reasonably direct, and convenient connections between primary building entrances and all adjacent parking areas, recreational areas/playgrounds, and public rights-of-way and crosswalks based on all of the following criteria:*
 - a. *Pedestrian pathways are designed primarily for pedestrian safety and convenience, meaning they are free from hazards and provide a reasonably smooth and consistent surface.*
 - b. *The pathway is reasonably direct. A pathway is reasonably direct when it follows a route between destinations that does not involve a significant amount of unnecessary out-of-direction travel.*
 - c. *The pathway connects to all primary building entrances and is consistent with the Americans with Disabilities Act (ADA) requirements.*
 - d. *All parking lots larger than three acres in size shall provide an internal bicycle and pedestrian pathway pursuant to Section 4.155(.03)(B.)(3.)(d.).*

Response: The site is a residential development and includes a public street (SW Windflower Street) with sidewalks on both sides accessed from SW Frog Pond Lane. The street extends north and east to connect to future development of the adjacent property to the east. Sheets C1.20 detail proposed cross sections and C1.40 details the proposed middle housing land division.

- 3. *Vehicle/Pathway Separation. Except as required for crosswalks, per subsection 4, below, where a pathway abuts a driveway or street it shall be vertically or horizontally separated from the vehicular lane. For example, a pathway may be vertically raised six inches above the abutting travel lane, or horizontally separated by a row of bollards.*

Response: The site includes a local street (SW Windflower Street) with 5-ft. wide sidewalks that are separated from vehicle travel lanes. This development will construct a portion of the Boeckman Creek Trail, which will connect to proposed SW Windflower Street, but will not otherwise connect to vehicle use areas. This standard is met.

- 4. *Crosswalks. Where a pathway crosses a parking area or driveway, it shall be clearly marked with contrasting paint or paving materials (e.g., pavers, light-color concrete inlay between asphalt, or similar contrast).*

Response: The proposed sidewalks and trail do not cross a parking area. Sidewalks will traverse through residential driveways meeting the design and material standards of the TSP. This standard is met.

5. *Pathway Width and Surface. Primary pathways shall be constructed of concrete, asphalt, brick/masonry pavers, or other durable surface, and not less than five (5) feet wide. Secondary pathways and pedestrian trails may have an alternative surface except as otherwise required by the ADA.*

Response: The proposed sidewalks will be constructed of concrete, asphalt, brick/masonry pavers, or other durable surfaces, and are 5 ft. wide. The proposed trail will be constructed of concrete and be 10 ft. wide. This standard is met.

6. *All pathways shall be clearly marked with appropriate standard signs.*
[Added by Ord. #719, 6/17/13]

Response: The pedestrian pathways will be signed as required.

B. Section 4.155. General Regulations - Parking, Loading and Bicycle Parking.

[...]

(.02) *General Provisions:*

- A. *The provision and maintenance of off-street parking spaces is a continuing obligation of the property owner. The standards set forth herein shall be considered by the Development Review Board as minimum criteria.*
 1. *The Board shall have the authority to grant variances or planned development waivers to these standards in keeping with the purposes and objectives set forth in the Comprehensive Plan and this Code.*
 2. *Waivers to the parking, loading, or bicycle parking standards shall only be issued upon a findings that the resulting development will have no significant adverse impact on the surrounding neighborhood, and the community, and that the development considered as a whole meets the purposes of this section.*
- B. *No area shall be considered a parking space unless it can be shown that the area is accessible and usable for that purpose, and has maneuvering area for the vehicles, as determined by the Planning Director.*
- C. *In cases of enlargement of a building or a change of use from that existing on the effective date of this Code, the number of parking spaces required shall be based on the additional floor area of the enlarged or additional building, or changed use, as set forth in this Section. Current development standards, including parking area landscaping and screening, shall apply only to the additional approved parking area.*
- D. *In the event several uses occupy a single structure or lot, the total requirement for off-street parking shall be the sum of the requirements of the several uses computed separately, except as modified by subsection "E," below. Within the TC Zone, the cumulative number of parking spaces required by this subsection may be reduced by 25%.*
- E. *Owners of two or more uses, structures, or lots may utilize jointly the same parking area when the peak hours of operation do not overlap, provided satisfactory legal evidence is presented in the form of deeds, leases, or contracts securing full and permanent access to such parking areas for all the parties jointly using them.*

- F. *Off-street parking spaces existing prior to the effective date of this Code may be included in the amount necessary to meet the requirements in case of subsequent enlargement of the building or use to which such spaces are necessary.*
 - G. *Off-Site Parking. Except for single-family dwellings and middle housing, the vehicle parking spaces required by this Chapter may be located on another lot, provided the lot is within 500 feet of the use it serves and the DRB has approved the off-site parking through the Land Use Review. The distance from the parking area to the use shall be measured from the nearest parking space to the main building entrance, following a sidewalk or other pedestrian route. Within the TC Zone there is no maximum distance to an off-site location provided the off-site parking is located within the TC Zone. The right to use the off-site parking must be evidenced in the form of recorded deeds, easements, leases, or contracts securing full and permanent access to such parking areas for all the parties jointly using them. Within the TC zone, there is no maximum distance to an off-site location provided the off-site parking is located within the TC Zone.*
 - H. *The conducting of any business activity shall not be permitted on the required parking spaces unless a temporary use permit is approved pursuant to Section 4.163.*
 - I. *Where the boundary of a parking lot adjoins or is within a residential district, such parking lot shall be screened by a sight-obscuring fence or planting. The screening shall be continuous along that boundary and shall be at least six feet in height.*
 - J. *Parking spaces along the boundaries of a parking lot over 650 square feet in area, excluding access areas, shall be provided with a sturdy bumper guard or curb at least six inches high and located far enough within the boundary to prevent any portion of a car within the lot from extending over the property line or interfering with required screening or sidewalks.*
 - K. *All areas used for parking and maneuvering of cars shall be surfaced with asphalt, concrete, or other surface, such as pervious materials (i. e. pavers, concrete, asphalt) that is found by the City's authorized representative to be suitable for the purpose. In all cases, suitable drainage, meeting standards set by the City's authorized representative shall be provided.*
 - L. *Artificial lighting which may be provided shall be so limited or deflected as not to shine into adjoining structures or into the eyes of passers-by.*
 - M. *Off-street parking requirements for types of uses and structures not specifically listed in this Code shall be determined by the Development Review Board if an application is pending before the Board. Otherwise, the requirements shall be specified by the Planning Director, based upon consideration of comparable uses.*
 - N. *Up to 40% of the off-street spaces may be compact car spaces as identified in Section 4.001 - "Definitions," and shall be appropriately identified.*
 - O. *Where off-street parking areas are designed for motor vehicles to overhang beyond curbs, planting areas adjacent to said curbs shall be increased to a minimum of seven feet in depth. This standard shall apply to a double row of parking, the net effect of which shall be to create a planted area that is a minimum of seven feet in depth.*
 - P. *Parklets are permitted within the TC Zone on up to two parking spaces per block and shall be placed in front of the business. Placement of parklet requires a temporary right-of-way use permit and approval by the City Engineer.*
- [...]

Response: Generally, these provisions apply to multifamily and commercial development, which is not proposed within Frog Pond Overlook. These provisions are not applicable.

(.03) Minimum and Maximum Off-Street Parking Requirements:

- A. *Parking and loading or delivery areas shall be designed with access and maneuvering area adequate to serve the functional needs of the site and shall:*

1. *Separate loading and delivery areas and circulation from customer and/or employee parking and pedestrian areas. Circulation patterns shall be clearly marked.*
 2. *To the greatest extent possible, separate vehicle and pedestrian traffic.*
- B. *Parking areas over 650 square feet, excluding access areas, and loading or delivery areas shall be landscaped to minimize the visual dominance of the parking or loading area, as follows: [...]*

Response: There is no off-street loading required or proposed for the proposed residential development. These provisions are not applicable.

- C. *Off Street Parking shall be designed for safe and convenient access that meets ADA and ODOT standards. All parking areas which contain ten (10) or more parking spaces, shall for every 50 standard spaces., provide one ADA-accessible parking space that is constructed to building code standards, Wilsonville Code 9.000.*
- D. *Where possible, parking areas shall be designed to connect with parking areas on adjacent sites so as to eliminate the necessity for any mode of travel of utilizing the public street for multiple accesses or cross movements. In addition, on-site parking shall be designed for efficient on-site circulation and parking.*
- E. *In all multi-family dwelling developments, there shall be sufficient areas established to provide for parking and storage of motorcycles, mopeds and bicycles. Such areas shall be clearly defined and reserved for the exclusive use of these vehicles.*
- F. *Except for single-family dwelling units and middle housing, on-street parking spaces, directly adjoining the frontage of and on the same side of the street as the subject property, may be counted towards meeting the minimum off-street parking standards.*

Response: There are no dwelling units proposed under this review. It is expected that each future dwelling unit will have a garage and a minimum of two off-street parking spaces. There are no public off-street parking areas required or proposed for the proposed residential development. The required parking is being provided on-site. On-street parking spaces are not requested to count toward the minimum standards.

- G. *Tables 5 shall be used to determine the minimum and maximum parking standards for various land uses. The minimum number of required parking spaces shown on Tables 5 shall be determined by rounding to the nearest whole parking space. For example, a use containing 500 square feet, in an area where the standard is one space for each 400 square feet of floor area, is required to provide one off-street parking space. If the same use contained more than 600 square feet, a second parking space would be required. Structured parking and on-street parking are exempted from the parking maximums in Table 5.*

Response: Table 5 requires that single-family units and middle housing provide one parking space per dwelling unit, and those greater than 1,000 sq. ft. in size are encouraged to have two spaces. There is no maximum number listed. Each dwelling unit is anticipated to provide at least two parking spaces within garages. This standard is met.

- H. *Electrical Vehicle Charging Stations:*
1. *Parking spaces designed to accommodate and provide one or more electric vehicle charging stations on site may be counted towards meeting the minimum off-street parking standards.*
 2. *Modification of existing parking spaces to accommodate electric vehicle charging stations on site is allowed outright.*

Response: No electrical vehicle charging stations are proposed at this time.

I. Motorcycle parking:

1. *Motorcycle parking may substitute for up to five spaces or five percent of required automobile parking, whichever is less. For every four motorcycle parking spaces provided, the automobile parking requirement is reduced by one space.*
2. *Each motorcycle space must be at least four feet wide and eight feet deep. Existing parking may be converted to take advantage of this provision.*

Response: No motorcycle parking is proposed.

(.04) Bicycle Parking:

A. Required Bicycle Parking—General Provisions:

1. *The required minimum number of bicycle parking spaces for each use category is shown in Table 5, Parking Standards.*
2. *Bicycle parking spaces are not required for accessory buildings. If a primary use is listed in Table 5, bicycle parking is not required for the accessory use.*
3. *When there are two or more primary uses on a site, the required bicycle parking for the site is the sum of the required bicycle parking for the individual primary uses.*
4. *Bicycle parking space requirements may be waived by the Development Review Board per Section 4.118(.03)A.9. and 10.*

Response: Table 5 states that there is no minimum bicycle parking requirement for single-family units and middle housing. These provisions are not applicable.

[...]

(.05) Minimum Off-Street Loading Requirements: [...]

Response: There is no off-street loading requirement for single-family homes. These provisions are not applicable.

(.06) Carpool and Vanpool Parking Requirements: [...]

Response: There is no carpool or vanpool parking requirement for single-family homes. These provisions are not applicable.

[...]

C. Section 4.156. Sign Code Regulations.

Section 4.156.07. Sign Regulations In Residential Zones.

[...]

Response: No signs are proposed at this time. Future signs will be subject to these regulations.

D. Section 4.167. General Regulations - Access, Ingress and Egress.

- (.01)** *Each access onto streets or private drives shall be at defined points as approved by the City and shall be consistent with the public's health, safety and general welfare. Such defined points of access shall be approved at the time of issuance of a building permit if not previously determined in the development permit.*

Response: Proposed driveway access onto streets and private drives is shown in Sheet C1.10.

E. Section 4.169. General Regulations – Double-Frontage Lots.

- (.01) *Buildings on double frontage lots (i.e., through lots) and corner lots must meet the front yard setback for principal buildings on both streets or tracts with a private drive. [Amended by Ord. 682, 9/9/10]*
- (.02) *Given that double-frontage lots tend to have one end that is regarded as a rear yard by the owner, the Development Review Board may establish special maintenance conditions to apply to such areas. Such conditions may include the requirement that the subject homeowners association, if any, be responsible for the on-going maintenance of the street frontage areas of double-frontage lots.*

Response: There are no double-frontage lots proposed in this development. These provisions are not applicable.

F. Section 4.171. General Regulations - Protection of Natural Features and Other Resources.

[...]

(.02) **General Terrain Preparation:**

- A. *All developments shall be planned, designed, constructed and maintained with maximum regard to natural terrain features and topography, especially hillside areas, floodplains, and other significant landforms.*
- B. *All grading, filling and excavating done in connection with any development shall be in accordance with the Uniform Building Code*
- C. *In addition to any permits required under the Uniform Building Code, all developments shall be planned, designed, constructed and maintained so as to:*
 1. *Limit the extent of disturbance of soils and site by grading, excavation and other land alterations.*
 2. *Avoid substantial probabilities of: (1) accelerated erosion; (2) pollution, contamination, or siltation of lakes, rivers, streams and wetlands; (3) damage to vegetation; (4) injury to wildlife and fish habitats.*
 3. *Minimize the removal of trees and other native vegetation that stabilize hillsides, retain moisture, reduce erosion, siltation and nutrient runoff, and preserve the natural scenic character.*

Response: The site has been planned and designed to avoid the natural features on the site, including a SROZ in the northwest portion of the property, and significant slopes within the SROZ on site's western boundary. Grading, filling, and excavating will be conducted in accordance with the Uniform Building Code. The site will be protected with erosion control measures and trees to be preserved on site will be staked prior to commencement of site work to avoid damage to vegetation or injury to habitat. The removal of trees is necessary for site development, but replacement trees will be planted per the provisions of this code.

- (.03) **Hillsides:** *All developments proposed on slopes greater than 25% shall be limited to the extent that: [...]*

Response: No development on slopes greater than 25% are proposed.

(.04) **Trees and Wooded Areas.**

- A. *All developments shall be planned, designed, constructed and maintained so that:*
 1. *Existing vegetation is not disturbed, injured, or removed prior to site development and prior to an approved plan for circulation, parking and structure location.*

2. *Existing wooded areas, significant clumps/groves of trees and vegetation, and all trees with a diameter at breast height of six inches or greater shall be incorporated into the development plan and protected wherever feasible.*
 3. *Existing trees are preserved within any right-of-way when such trees are suitably located, healthy, and when approved grading allows.*
- B. Trees and woodland areas to be retained shall be protected during site preparation and construction according to City Public Works design specifications, by:*
1. *Avoiding disturbance of the roots by grading and/or compacting activity.*
 2. *Providing for drainage and water and air filtration to the roots of trees which will be covered with impermeable surfaces.*
 3. *Requiring, if necessary, the advisory expertise of a registered arborist/horticulturist both during and after site preparation.*
 4. *Requiring, if necessary, a special maintenance, management program to insure survival of specific woodland areas of specimen trees or individual heritage status trees.*

Response: Existing vegetation will not be disturbed, injured or removed prior to land use and permit approvals. Existing trees have been retained wherever possible; however, 109 trees are proposed to be removed to provide area for home construction and site work. No trees are proposed to be removed from the SROZ Impact Area.

(.05) *High Voltage Powerline Easements and Rights of Way and Petroleum Pipeline Easements:*

- A. Due to the restrictions placed on these lands, no residential structures shall be allowed within high voltage powerline easements and rights-of-way and petroleum pipeline easements, and any development, particularly residential, adjacent to high voltage powerline easements and rights-of-way and petroleum pipeline easements shall be carefully reviewed.*
- B. Any proposed non-residential development within high voltage powerline easements and rights-of-way and petroleum pipeline easements shall be coordinated with and approved by the Bonneville Power Administration, Portland General Electric Company or other appropriate utility, depending on the easement or right-of-way ownership.*

Response: No high voltage powerline easements or petroleum pipeline easements are present on site.

(.06) *Hazards to Safety: Purpose:*

- A. To protect lives and property from natural or human-induced geologic or hydrologic hazards and disasters.*
- B. To protect lives and property from damage due to soil hazards.*
- C. To protect lives and property from forest and brush fires.*
- D. To avoid financial loss resulting from development in hazard areas.*

Response: The portions of the site proposed for development contain no hydrologic, soil, fire, or other hazards. In the western portion of the site, where no development is proposed, there is a temporary access easement near the top of the steep slope. The previously submitted geotechnical report, associated with DB22-0002 Frog Pond Overlook approval, concluded that planned utility lines and a temporary access way can be safely constructed as advised in the report.

(.07) Standards for Earth Movement Hazard Areas:

- A. *No development or grading shall be allowed in areas of land movement, slump or earth flow, and mud or debris flow, except under one of the following conditions:*
 - 1. *Stabilization of the identified hazardous condition based on established and proven engineering techniques which ensure protection of public and private property. Appropriate conditions of approval may be attached by the City.*
 - 2. *An engineering geologic study approved by the City establishing that the site is stable for the proposed use and development. The study shall include the following:*
 - a. *Index map.*
 - b. *Project description, to include: location; topography, drainage, vegetation; discussion of previous work; and discussion of field exploration methods.*
 - c. *Site geology, to include: site geologic map; description of bedrock and superficial materials including artificial fill; location of any faults, folds, etc.; and structural data including bedding, jointing, and shear zones.*
 - d. *Discussion and analysis of any slope stability problems.*
 - e. *Discussion of any off-site geologic conditions that may pose a potential hazard to the site or that may be affected by on-site development.*
 - f. *Suitability of site for proposed development from geologic standpoint.*
 - g. *Specific recommendations for cut slope stability, seepage and drainage control, or other design criteria to mitigate geologic hazards.*
 - h. *Supportive data, to include: cross sections showing subsurface structure; graphic logs of subsurface explorations; results of laboratory tests; and references.*
 - i. *Signature and certification number of engineering geologist registered in the State of Oregon.*
 - j. *Additional information or analyses as necessary to evaluate the site.*
- B. *Vegetative cover shall be maintained or established for stability and erosion control purposes.*
- C. *Diversion of storm water into these areas shall be prohibited.*
- D. *The principal source of information for determining earth movement hazards is the State Department of Geology and Mineral Industries (DOGAMI) Bulletin 99 and any subsequent bulletins and accompanying maps. Approved site specific engineering geologic studies shall be used to identify the extent and severity of the hazardous conditions on the site, and to update the earth movement hazards database.*

Response: The DOGAMI map indicates that portions of the site are within a mapped landslide hazard area. Geotechnical investigations have been completed for the subject property, and no actual earth movement hazards have been identified.

(.08) Standards for Soil Hazard Areas:

- A. *Appropriate siting and design safeguards shall insure structural stability and proper drainage of foundation and crawl space areas for development on land with any of the following soil conditions: wet or high water table; high shrink-swell capability; compressible or organic; and shallow depth-to-bedrock.*
- B. *The principal source of information for determining soil hazards is the State DOGAMI Bulletin 99 and any subsequent bulletins and accompanying maps. Approved site-specific soil studies shall be used to identify the extent and severity of the hazardous conditions on the site, and to update the soil hazards database accordingly.*

Response: Geotechnical investigations have been completed for the subject property, and no soil hazard areas have been identified.

(.09) Historic Protection: Purpose:

- A. *To preserve structures, sites, objects, and areas within the City of Wilsonville having historic, cultural, or archaeological significance.*
[...]

Response: No historic, cultural, or archaeological items have been identified on the site.

[...]

G. Section 4.175. Public Safety and Crime Prevention.

- (.01)** *All developments shall be designed to deter crime and insure public safety.*
(.02) *Addressing and directional signing shall be designed to assure identification of all buildings and structures by emergency response personnel, as well as the general public.*
(.03) *Areas vulnerable to crime shall be designed to allow surveillance. Parking and loading areas shall be designed for access by police in the course of routine patrol duties.*
(.04) *Exterior lighting shall be designed and oriented to discourage crime.*

Response: The Frog Pond Overlook development has been designed to deter crime and ensure public safety. SW Windflowers Street will be lit for visibility and safety, as will the proposed trail. Homes will be oriented toward the street to provide “eyes on the street.” All dwellings will be addressed per Building and Fire Department requirements to allow identification for emergency response personnel. No parking and loading areas are proposed. Dwellings will have exterior porch lighting, which will support the streetlights to provide safety and visibility. These standards are met.

H. Section 4.176. Landscaping, Screening, and Buffering.

[...]

(.02) Landscaping and Screening Standards.

[...]

C. General Landscaping Standard.

[...]

Required materials. Shrubs and trees, other than street trees, may be grouped. Ground cover plants must fully cover the remainder of the landscaped area (see Figure 21: General Landscaping). The General Landscaping Standard has two different requirements for trees and shrubs:

- a. *Where the landscaped area is less than 30 feet deep, one tree is required for every 30 linear feet.*
- b. *Where the landscaped area is 30 feet deep or greater, one tree is required for every 800 square feet and two high shrubs or three low shrubs are required for every 400 square feet.*

Response: The proposed development consists of single-family and middle housing dwellings, which are generally subject to the General Landscape Standard. The landscape plan included as Sheets L2.00, L2.10 and L3.00 illustrate the location and type of landscaping within public rights-of-way and tracts.

D. Low Screen Landscaping Standard.

1. *Intent. The Low Screen Landscaping Standard is a landscape treatment that uses a combination of distance and low screening to separate uses or developments. It is*

intended to be applied in situations where low screening is adequate to soften the impact of one use or development on another, or where visibility between areas is more important than a total visual screen. The Low Screen Landscaping Standard is usually applied along street lot lines or in the area separating parking lots from street rights-of-way.

2. *Required materials. The Low Screen Landscaping Standard requires sufficient low shrubs to form a continuous screen three feet high and 95% opaque, year-round. In addition, one tree is required for every 30 linear feet of landscaped area, or as otherwise required to provide a tree canopy over the landscaped area. Ground cover plants must fully cover the remainder of the landscaped area. A three foot high masonry wall or a berm may be substituted for the shrubs, but the trees and ground cover plants are still required. When applied along street lot lines, the screen or wall is to be placed along the interior side of the landscaped area. (See Figure 22: Low Screen Landscaping).*

Response: The proposed development consists of single-family and middle housing dwellings, which are generally subject to the General Landscape Standard.

E. Low Berm Landscaping Standard:

1. *Intent. The Low Berm Standard is intended to be applied in situations where moderate screening to reduce both visual and noise impacts is needed to protect abutting uses or developments from one-another, and where it is desirable and practical to provide separation by both distance and sight-obscuring materials. This screening is most important where either, or both, of the abutting uses or developments can be expected to be particularly sensitive to noise or visual impacts.*
2. *Required materials. The Low Berm Standard requires a berm at least two feet six inches high along the interior side of the landscaped area (see Figure 23: Low Berm Landscaping). If the berm is less than three feet high, low shrubs meeting the Low Screen Landscaping Standard, above, are to be planted along the top of the berm, assuring that the screen is at least three feet in height. In addition, one tree is required for every 30 linear feet of berm, or as otherwise required to provide a tree canopy over the landscaped area. Ground cover plants must fully cover the remainder of the landscaped area.*

Response: There are no visual or noise impacts anticipated from the proposed development, and low berm landscaping is not required or proposed.

F. High Screen Landscaping Standard.

1. *Intent. The High Screen Landscaping Standard is a landscape treatment that relies primarily on screening to separate uses or developments. It is intended to be applied in situations where visual separation is required.*
2. *Required materials. The High Screen Landscaping Standard requires sufficient high shrubs to form a continuous screen at least six feet high and 95% opaque, year-round. In addition, one tree is required for every 30 linear feet of landscaped area, or as otherwise required to provide a tree canopy over the landscaped area. Ground cover plants must fully cover the remainder of the landscaped area. A six foot high masonry wall or a berm may be substituted for the shrubs, but the trees and ground cover plants are still required. When applied along street lot lines, the screen or wall is to be placed along the interior side of the landscaped area. (See Figure 24: High Screen Landscaping).*

Response: The proposed residential development is located adjacent to future residential development and a natural area. No screening is required or provided between uses.

G. High Wall Standard.

1. *Intent. The High Wall Standard is intended to be applied in situations where extensive screening to reduce both visual and noise impacts is needed to protect abutting uses or developments from one-another. This screening is most important where either, or both, of the abutting uses or developments can be expected to be particularly sensitive to noise or visual impacts, or where there is little space for physical separation.*
2. *Required materials. The High Wall Standard requires a masonry wall at least six feet high along the interior side of the landscaped area (see Figure 25: High Wall Landscaping). In addition, one tree is required for every 30 linear feet of wall, or as otherwise required to provide a tree canopy over the landscaped area. Ground cover plants must fully cover the remainder of the landscaped area.*

Response: There are no visual or noise impacts anticipated from the proposed development, and high walls are not required or proposed.

H. High Berm Standard.

1. *Intent. The High Berm Standard is intended to be applied in situations where extensive screening to reduce both visual and noise impacts is needed to protect abutting uses or developments from one-another, and where it is desirable and practical to provide separation by both distance and sight-obscuring materials. This screening is most important where either, or both, of the abutting uses or developments can be expected to be particularly sensitive to noise or visual impacts.*
2. *Required materials. The High Berm Standard requires a berm at least four feet high along the interior side of the landscaped area (see Figure 26: High Berm Landscaping). If the berm is less than six feet high, low shrubs meeting the Low Screen Landscaping Standard, above, are to be planted along the top of the berm, assuring that the screen is at least six feet in height. In addition, one tree is required for every 30 linear feet of berm, or as otherwise required to provide a tree canopy over the landscaped area. Ground cover plants must fully cover the remainder of the landscaped area.*

Response: There are no visual or noise impacts anticipated from the proposed development, and a high berm is not required or provided.

I. Partially Sight-Obscuring Fence Standard.

1. *Intent. The Partially Sight-Obscuring Fence Standard is intended to provide a tall, but not totally blocked, visual separation. The standard is applied where a low level of screening is adequate to soften the impact of one use or development on another, and where some visibility between abutting areas is preferred over a total visual screen. It can be applied in conjunction with landscape plantings or applied in areas where landscape plantings are not necessary and where nonresidential uses are involved.*
2. *Required materials. Partially Sight-Obscuring Fence Standard are to be at least six feet high and at least 50% sight-obscuring. Fences may be made of wood (other than plywood or particle-board), metal, bricks, masonry or other permanent materials (see Figure 27: Partially Sight-Obscuring Fence).*

J. Fully Sight-Obscuring Fence Standard.

1. *Intent. The Fully Sight-Obscuring Fence Standard is intended to provide a totally blocked visual separation. The standard is applied where full visual screening is needed to reduce the impact of one use or development on another. It can be applied in conjunction with landscape plantings or applied in areas where landscape plantings are not necessary.*
2. *Required materials. Fully sight-obscuring fences are to be at least six feet high and 100% sight-obscuring. Fences may be made of wood (other than plywood or particle-board), metal, bricks, masonry or other permanent materials (see Figure 28: Totally Sight-Obscuring Fence).*

Response: There is no need for partially or totally blocked visual separation. Sight-obscuring fencing is not provided.

(.03) Landscape Area. *Not less than 15% of the total lot area, shall be landscaped with vegetative plant materials. The 10% parking area landscaping required by section 4.155.03(B)(1) is included in the 15% total lot landscaping requirement. Landscaping shall be located in at least three separate and distinct areas of the lot, one of which must be in the contiguous frontage area. Planting areas shall be encouraged adjacent to structures. Landscaping shall be used to define, soften or screen the appearance of buildings and off-street parking areas. Materials to be installed shall achieve a balance between various plant forms, textures, and heights. The installation of native plant materials shall be used whenever practicable. (For recommendations refer to the Native Plant List maintained by the City of Wilsonville).*

Response: At least 15% of the total lot area for each single-family and/or middle housing dwelling will be landscaped; conformance with this standard will be reviewed at the time of building permit submittal. There are no parking areas proposed and no parking area landscaping is required.

(.04) Buffering and Screening. *Additional to the standards of this subsection, the requirements of the Section 4.137.5 (Screening and Buffering Overlay Zone) shall also be applied, where applicable.*

- A. *All intensive or higher density developments shall be screened and buffered from less intense or lower density developments.*
- B. *Activity areas on commercial and industrial sites shall be buffered and screened from adjacent residential areas. Multi-family developments shall be screened and buffered from single-family areas.*
- C. *All exterior, roof and ground mounted, mechanical and utility equipment shall be screened from ground level off-site view from adjacent streets or properties.*
- D. *All outdoor storage areas shall be screened from public view unless visible storage has been approved for the site by the Development Review Board or Planning Director acting on a development permit.*
- E. *In all cases other than for industrial uses in industrial zones, landscaping shall be designed to screen loading areas and docks, and truck parking.*
- F. *In any zone any fence over six feet high measured from soil surface at the outside of fenceline shall require Development Review Board approval.*

Response: The requirements of 4.137.5 are applicable along the edge of nonresidential zones abutting, or located directly across the street from, residential zones. The proposed development is located within a residential zone and is anticipated to abut residential development in accordance with the Frog Pond Master Plan. These provisions are not applicable.

(.05) Sight-Obscuring Fence or Planting. *The use for which a sight-obscuring fence or planting is required shall not begin operation until the fence or planting is erected or in place and approved by the City. A temporary occupancy permit may be issued upon a posting of a bond or other security equal to 110% of the cost of such fence or planting and its installation. (See Sections 4.400 to 4.470 for additional requirements.)*

Response: No sight-obscuring fences or planting are required between the proposed residential use and adjacent uses. This standard is not applicable.

(.06) Plant Materials.

- A. *Shrubs and Ground Cover. All required ground cover plants and shrubs must be of sufficient size and number to meet these standards within three years of planting. Non-horticultural plastic sheeting or other impermeable surface shall not be placed under mulch. Native topsoil shall be preserved and reused to the extent feasible. Surface mulch or bark dust are to be fully raked into soil of appropriate depth, sufficient to control erosion, and are confined to areas around plantings. Areas exhibiting only surface mulch, compost or barkdust are not to be used as substitutes for plant areas.*
1. *Shrubs. All shrubs shall be well branched and typical of their type as described in current AAN Standards and shall be equal to or better than 2-gallon containers and ten inches to 12 inches spread.*
 2. *Ground cover. Shall be equal to or better than the following depending on the type of plant materials used: gallon containers spaced at four feet on center minimum, four inch pot spaced two feet on center minimum, two one-fourth inch pots spaced at 18 inch on center minimum. No bare root planting shall be permitted. Ground cover shall be sufficient to cover at least 80% of the bare soil in required landscape areas within three years of planting. Where wildflower seeds are designated for use as a ground cover, the City may require annual re-seeding as necessary.*
 3. *Turf or lawn in non-residential developments. Shall not be used to cover more than 10% of the landscaped area, unless specifically approved based on a finding that, due to site conditions and availability of water, a larger percentage of turf or lawn area is appropriate. Use of lawn fertilizer shall be discouraged. Irrigation drainage runoff from lawns shall be retained within lawn areas.*
 4. *Plant materials under trees or large shrubs. Appropriate plant materials shall be installed beneath the canopies of trees and large shrubs to avoid the appearance of bare ground in those locations.*
 5. *Integrate compost-amended topsoil in all areas to be landscaped, including lawns, to help detain runoff, reduce irrigation and fertilizer needs, and create a sustainable, low-maintenance landscape.*

Response: A landscape plan has been included with the submission. Sheets L2.00 and L2.10 illustrate the proposed landscape plan throughout the development while Sheet L3.00 provides notes and details of proposed landscaping. Additionally, Sheets L1.00 and L1.10 address Tree Protection Plan and Tree Inventory.

- B. *Trees. All trees shall be well-branched and typical of their type as described in current American Association of Nurserymen (AAN) Standards and shall be balled and burlapped. The trees shall be grouped as follows:*
1. *Primary trees which define, outline or enclose major spaces, such as Oak, Maple, Linden, and Seedless Ash, shall be a minimum of two inch caliper.*
 2. *Secondary trees which define, outline or enclose interior areas, such as Columnar Red Maple, Flowering Pear, Flame Ash, and Honeylocust, shall be a minimum of 1¾ inch to 2 inch caliper.*

3. *Accent trees which, are used to add color, variation and accent to architectural features, such as Flowering Pear and Kousa Dogwood, shall be 1¾ inch minimum caliper.*
4. *Large conifer trees such as Douglas Fir or Deodar Cedar shall be installed at a minimum height of eight feet.*
5. *Medium-sized conifers such as Shore Pine, Western Red Cedar or Mountain Hemlock shall be installed at a minimum height of five to six feet.*

Response: Sheets L1.00 and L1.10 address Tree Protection Plan and Tree Inventory.

- C. *Where a proposed development includes buildings larger than 24 feet in height or greater than 50,000 square feet in footprint area, the Planning Director or the Development Review Board, as applicable, may require larger or more mature plant materials.*
1. *At maturity, proposed trees shall be at least one-half the height of the building to which they are closest, and building walls longer than 50 feet shall require tree groups located no more than 50 feet on center, to break up the length and height of the façade.*
 2. *Either fully branched deciduous or evergreen trees may be specified depending upon the desired results. Where solar access is to be preserved, only solar-friendly deciduous trees are to be used. Where year-round sight obscuring is the highest priority, evergreen trees are to be used.*
 3. *The following standards are to be applied:*
 - a. *Deciduous trees:*
 - i. *Minimum height of ten feet; and*
 - ii. *Minimum trunk diameter (caliper) of two inches (measured at four and one-half feet above grade).*
 - b. *Evergreen trees: Minimum height of 12 feet.*

Response: Some of the proposed residential dwellings will exceed 24 ft. in height but will be far less than 50,000 sq. ft. in footprint area. Requirements for larger or more mature plant materials are not warranted.

- D. *Street Trees. In order to provide a diversity of species, the Development Review Board may require a mix of street trees throughout a development. Unless the Board waives the requirement for reasons supported by a finding in the record, different types of street trees shall be required for adjoining blocks in a development.*
1. *All trees shall be standard base grafted, well branched and typical of their type as described in current AAN Standards and shall be balled and burlapped (b&b). Street trees shall be planted at sizes in accordance with the following standards:*
 - a. *Arterial streets—Three inches minimum caliper*
 - b. *Collector streets—Two inches minimum caliper.*
 - c. *Local streets or residential private access drives—1¾ inches minimum caliper.*
 - d. *Accent or median tree—1¾ inches minimum caliper.*

Response: A landscape plan has been included with the submission. Sheets L2.00 and L2.10 illustrate the proposed landscape plan throughout the development while Sheet L3.00 provides notes and details of proposed landscaping. Additionally, Sheets L1.00 and L1.10 address Tree Protection Plan and Tree Inventory. Standards are met.

2. *The following trees and varieties thereof are considered satisfactory street trees in most circumstances; however, other varieties and species are encouraged and will be considered:*

- a. *Trees over 50 feet mature height: Quercus garryana (Native Oregon White Oak), Quercus rubra borealis (Red Oak), Acer Macrophyllum (Native Big Leaf Maple), Acer nigrum (Green Column Black Maple), Fraxinus americanus (White Ash), Fraxinus pennsylvannica 'Marshall' (Marshall Seedless Green Ash), Quercus coccinea (Scarlet Oak), Quercus pulustris (PinOak), Tilia americana (American Linden).*
- b. *Trees under 50 feet mature height: Acer rubrum (Red Sunset Maple), Cornus nuttallii (Native Pacific Dogwood), Gleditsia triacanthos (Honey Locust), Pyrus calleryana 'Bradford' (Bradford Pear), Tilia cordata (Little Leaf Linden), Fraxinus oxycarpa (Flame Ash).*
- c. *Other street tree species. Other species may be specified for use in certain situations. For instance, evergreen species may be specified where year-round color is desirable and no adverse effect on solar access is anticipated. Water-loving species may be specified in low locations where wet soil conditions are anticipated.*

Response: A landscape plan has been included with the submission. Sheets L2.00 and L2.10 illustrate the proposed landscape plan throughout the development while Sheet L3.00 provides notes and details of proposed landscaping. Additionally, Sheets L1.00 and L1.10 address Tree Protection Plan and Tree Inventory. The proposed street trees include Liriodendron Tulipifera 'Fastigiatum' (Tulip Tree) and Quercus Rubra (Red Oak). All trees listed here have been chosen from the approved street tree list for the Frog Pond West Master Plan, and they have been selected for the qualities that cause them to be frequently specified as street trees: predictable form, disease resistance, tidiness, and visual interest.

E. Types of Plant Species.

1. *Existing landscaping or native vegetation may be used to meet these standards, if protected and maintained during the construction phase of the development and if the plant species do not include any that have been listed by the City as prohibited. The existing native and non-native vegetation to be incorporated into the landscaping shall be identified.*
2. *Selection of plant materials. Landscape materials shall be selected and sited to produce hardy and drought-tolerant landscaping. Selection shall be based on soil characteristics, maintenance requirements, exposure to sun and wind, slope and contours of the site, and compatibility with other vegetation that will remain on the site. Suggested species lists for street trees, shrubs and groundcovers shall be provided by the City of Wilsonville.*
3. *Prohibited plant materials. The City may establish a list of plants that are prohibited in landscaped areas. Plants may be prohibited because they are potentially damaging to sidewalks, roads, underground utilities, drainage improvements, or foundations, or because they are known to be invasive to native vegetation.*

Response: A landscape plan has been included with the submission. Sheets L2.00 and L2.10 illustrate the proposed landscape plan throughout the development while Sheet L3.00 provides notes and details of proposed landscaping. Additionally, Sheets L1.00 and L1.10 address Tree Protection Plan and Tree Inventory. Those plans include proposed landscape materials with a mix of native trees, shrubs, and groundcovers. No prohibited plant materials are proposed.

F. *Tree Credit.*

Existing trees that are in good health as certified by an arborist and are not disturbed during construction may count for landscaping tree credit as follows (measured at four and one-half feet above grade and rounded to the nearest inch):

Existing trunk diameter	Number of Tree Credits
18 to 24 inches in diameter	3 tree credits
25 to 31 inches in diameter	4 tree credits
32 inches or greater	5 tree credits

1. *It shall be the responsibility of the owner to use reasonable care to maintain preserved trees. Trees preserved under this section may only be removed if an application for removal permit under Section 4.610.10(01)(H) has been approved. Required mitigation for removal shall be replacement with the number of trees credited to the preserved and removed tree.*
2. *Within five years of occupancy and upon notice from the City, the property owner shall replace any preserved tree that cannot be maintained due to disease or damage, or hazard or nuisance as defined in Chapter 6 of this code. The notice shall be based on complete information provided by an arborist Replacement with the number of trees credited shall occur within one (1) growing season of notice.*

Response: As shown on Sheets L1.00 and L2.00 and described in Appendix C, there are 155 trees on or near the site; 109 trees are proposed for removal, and 42 on-site trees and 4 off-site trees are to be preserved. Of the trees being preserved, 19 trees are 18 inches or more DBH. Per the calculations above and shown in Table 4 below, 70 tree credits are provided by protected trees.

Table 4 Tree Credits

Count	Tag #	Existing Trunk Diameter	Number of Tree Credits
1	30482	36 in.	5
2	31067	24 in.	3
3	31072	20 in.	3
4	31099	24 in.	3
5	31102	36 in.	5
6	31103	24 in.	3
7	31109	26 in.	4
8	31110	36 in.	5
9	31111	24 in.	3
10	31141	40 in.	5
11	31143	24 in.	3
12	31145	21 in.	3
13	31146	24 in.	3
14	31149	26 in.	4
15	31156	2 x 24 in.	3
16	31159	32 in.	5
17	31162	30 in.	4
18	31165	24 in.	3
19	31176	18 in.	3
Total			70

[...]

(.07) Installation and Maintenance.

- A. *Installation. Plant materials shall be installed to current industry standards and shall be properly staked to assure survival. Support devices (guy wires, etc.) shall not be allowed to interfere with normal pedestrian or vehicular movement.*
- B. *Maintenance. Maintenance of landscaped areas is the on-going responsibility of the property owner. Any landscaping installed to meet the requirements of this Code, or any condition of approval established by a City decision-making body acting on an application, shall be continuously maintained in a healthy, vital and acceptable manner. Plants that die are to be replaced in kind, within one growing season, unless appropriate substitute species are approved by the City. Failure to maintain landscaping as required in this Section shall constitute a violation of this Code for which appropriate legal remedies, including the revocation of any applicable land development permits, may result.*
- C. *Irrigation. The intent of this standard is to assure that plants will survive the critical establishment period when they are most vulnerable due to a lack of watering and also to assure that water is not wasted through unnecessary or inefficient irrigation. Approved irrigation system plans shall specify one of the following:*
 - 1. *A permanent, built-in, irrigation system with an automatic controller. Either a spray or drip irrigation system, or a combination of the two, may be specified.*
 - 2. *A permanent or temporary system designed by a landscape architect licensed to practice in the State of Oregon, sufficient to assure that the plants will become established and drought-tolerant.*
 - 3. *Other irrigation system specified by a licensed professional in the field of landscape architecture or irrigation system design.*
 - 4. *A temporary permit issued for a period of one year, after which an inspection shall be conducted to assure that the plants have become established. Any plants that have died, or that appear to the Planning Director to not be thriving, shall be appropriately replaced within one growing season. An inspection fee and a maintenance bond or other security sufficient to cover all costs of replacing the plant materials shall be provided, to the satisfaction of the Community Development Director. Additionally, the applicant shall provide the City with a written license or easement to enter the property and cause any failing plant materials to be replaced.*
- D. *Protection. All required landscape areas, including all trees and shrubs, shall be protected from potential damage by conflicting uses or activities including vehicle parking and the storage of materials.*

Response: All landscape areas will be watered by a fully automatic underground irrigation system. These standards are met.

(.08) Landscaping on Corner Lots. *All landscaping on corner lots shall meet the vision clearance standards of Section 4.177. If high screening would ordinarily be required by this Code, low screening shall be substituted within vision clearance areas. Taller screening may be required outside of the vision clearance area to mitigate for the reduced height within it.*

Response: High screening is not required on any corner lots and is not proposed. This standard is not applicable.

(.09) Landscape Plans. *Landscape plans shall be submitted showing all existing and proposed landscape areas. Plans must be drawn to scale and show the type, installation size, number and placement of materials. Plans shall include a plant material list. Plants*

are to be identified by both their scientific and common names. The condition of any existing plants and the proposed method of irrigation are also to be indicated. Landscape plans shall divide all landscape areas into the following categories based on projected water consumption for irrigation:

- A. High water usage areas (\pm two inches per week): small convoluted lawns, lawns under existing trees, annual and perennial flower beds, and temperamental shrubs;
 - B. Moderate water usage areas (\pm one inch per week): large lawn areas, average water-using shrubs, and trees;
 - C. Low water usage areas (Less than one inch per week, or gallons per hour): seeded fieldgrass, swales, native plantings, drought-tolerant shrubs, and ornamental grasses or drip irrigated areas.
 - D. Interim or unique water usage areas: areas with temporary seeding, aquatic plants, erosion control areas, areas with temporary irrigation systems, and areas with special water-saving features or water harvesting irrigation capabilities.
- These categories shall be noted in general on the plan and on the plant material list.

Response: A landscape plan has been included with the submission. Sheets L2.00 and L2.10 illustrate the proposed landscape plan throughout the development while Sheet L3.00 provides notes and details of proposed landscaping. Additionally, Sheets L1.00 and L1.10 address Tree Protection Plan and Tree Inventory.

(.10) Completion of Landscaping. *The installation of plant materials may be deferred for a period of time specified by the Board or Planning Director acting on an application, in order to avoid hot summer or cold winter periods, or in response to water shortages. In these cases, a temporary permit shall be issued, following the same procedures specified in subsection (.07)(C)(3), above, regarding temporary irrigation systems. No final Certificate of Occupancy shall be granted until an adequate bond or other security is posted for the completion of the landscaping, and the City is given written authorization to enter the property and install the required landscaping, in the event that the required landscaping has not been installed. The form of such written authorization shall be submitted to the City Attorney for review.*

Response: Acknowledged. No deferral is requested at this time but may be requested in the future subject to the scenarios above.

(.11) Street Trees Not Typically Part of Site Landscaping. *Street trees are not subject to the requirements of this Section and are not counted toward the required standards of this Section. Except, however, that the Development Review Board may, by granting a waiver or variance, allow for special landscaping within the right-of-way to compensate for a lack of appropriate on-site locations for landscaping. See subsection (.06), above, regarding street trees.*

Response: No waiver or variance for on-site landscaping is requested. This standard is not applicable.

(.12) Mitigation and Restoration Plantings. *A mitigation plan is to be approved by the City's Development Review Board before the destruction, damage, or removal of any existing native plants. Plantings intended to mitigate the loss of native vegetation are subject to the following standards. Where these standards conflict with other requirements of this Code, the standards of this Section shall take precedence. The desired effect of this section is to preserve existing native vegetation.*

- A. *Plant Sources. Plant materials are to be native and are subject to approval by the City. They are to be non-clonal in origin; seed source is to be as local as possible, and plants must be nursery propagated or taken from a pre-approved transplantation area. All of these requirements are to be addressed in any proposed mitigation plan.*
- B. *Plant Materials. The mitigation plan shall specify the types and installation sizes of plant materials to be used for restoration. Practices such as the use of pesticides, fungicides, and fertilizers shall not be employed in mitigation areas unless specifically authorized and approved.*
- C. *Installation. Install native plants in suitable soil conditions. Plant materials are to be supported only when necessary because of extreme winds at the site. Where support is necessary, all stakes, guy wires or other measures are to be removed as soon as the plants can support themselves. Protect from animal and fowl predation and foraging until establishment.*
- D. *Irrigation. Permanent irrigation systems are generally not appropriate in restoration situations, and manual or temporary watering of new plantings is often necessary. The mitigation plan shall specify the method and frequency of manual watering, including any that may be necessary after the first growing season.*
- E. *Monitoring and Reporting. Monitoring of native landscape areas is the on-going responsibility of the property owner. Plants that die are to be replaced in kind and quantity within one year. Written proof of the survival of all plants shall be required to be submitted to the City's Planning Department one year after the planting is completed.*

Response: The site is currently in residential and agricultural use, and site plantings consist primarily of grass and clustered trees. The existing grass and 109 trees will be removed for site development, generally to accommodate the planned street and desired lotting pattern. Tree removal will be mitigated as detailed in the response to Section 4.610.30. These standards are not applicable.

I. Section 4.177. Street Improvement Standards.

This section contains the City's requirements and standards for pedestrian, bicycle, and transit facility improvements to public streets, or within public easements. The purpose of this section is to ensure that development, including redevelopment, provides transportation facilities that are safe, convenient, and adequate in rough proportion to their impacts.

(.01) Development and related public facility improvements shall comply with the standards in this section, the Wilsonville Public Works Standards, and the Transportation System Plan, in rough proportion to the potential impacts of the development. Such improvements shall be constructed at the time of development or as provided by Section 4.140, except as modified or waived by the City Engineer for reasons of safety or traffic operations.

Response: The proposed public facility improvements are designed to be in substantial conformance with the standards in this section, the Wilsonville Public Works Standards, and the Transportation System Plan as modified by the Frog Pond Master Plan.

(.02) Street Design Standards.

- A. *All street improvements and intersections shall provide for the continuation of streets through specific developments to adjoining properties or subdivisions.*
 - 1. *Development shall be required to provide existing or future connections to adjacent sites through the use of access easements where applicable. Such easements shall be required in addition to required public street dedications as required in Section 4.236(.04).*

Response: The proposed SW Windflower Street has been designed to be substantially consistent with the Frog Pond West Master Plan. Frog Pond Lane is being improved to Local Street standards established in the TSP. Future connections to adjacent sites are anticipated to the east. This standard is met.

B. The City Engineer shall make the final determination regarding right-of-way and street element widths using the ranges provided in Chapter 3 of the Transportation System Plan and the additional street design standards in the Public Works Standards.

Response: No modifications to the proposed rights-of-way and street elements widths are proposed at this time. The development will construct the local street in accordance with applicable standards. Frog Pond Lane and SW Windflower Street will meet width and street element standards. See Sheet C1.20 for street cross sections.

C. Rights-of-way.

- 1. Prior to issuance of a Certificate of Occupancy Building permits or as a part of the recordation of a final plat, the City shall require dedication of rights-of-way in accordance with the Transportation System Plan. All dedications shall be recorded with the County Assessor's Office.*
- 2. The City shall also require a waiver of remonstrance against formation of a local improvement district, and all non-remonstrances shall be recorded in the County Recorder's Office as well as the City's Lien Docket, prior to issuance of a Certificate of Occupancy Building Permit or as a part of the recordation of a final plat.*
- 3. In order to allow for potential future widening, a special setback requirement shall be maintained adjacent to all arterial streets. The minimum setback shall be 55 feet from the centerline or 25 feet from the right-of-way designated on the Master Plan, whichever is greater.*

Response: This proposal includes the following right-of-way dedication as shown in Sheet C1.40 (Prelim. Subdivision Plat & Horizontal Control):

- ROW dedication of 9.5 feet along the site's frontage with SW Frog Pond Lane

The site does not have frontage on an arterial street; therefore, the special setback does not apply. These standards are met.

D. Dead-end Streets. New dead-end streets or cul-de-sac shall not exceed 200 feet in length, unless the adjoining land contains barriers such as existing buildings, railroads or freeways, or environmental constraints such as steep slopes, or major streams or rivers, that prevent future street extension and connection. A central landscaped island with rainwater management and infiltration are encouraged in cul-de-sac design. No more than 25 dwelling units shall take access to a new dead-end or cul-de-sac street unless it is determined that the traffic impacts on adjacent streets will not exceed those from a development of 25 or fewer units. All other dimensional standards of dead-end streets shall be governed by the Public Works Standards. Notification that the street is planned for future extension shall be posted on the dead-end street.

Response: SW Windflower Street is proposed to stub at the eastern boundary of the subject property with the intent for it to be extended upon that property's development. A vehicle turn-around is provided in Tract B. There are no proposed permanent dead-end streets or cul-de-sacs. This standard is not applicable.

- E. *Corner or clear vision area.*
1. *A clear vision area which meets the Public Works Standards shall be maintained on each corner of property at the intersection of any two streets, a street and a railroad or a street and a driveway. However, the following items shall be exempt from meeting this requirement:*
 - a. *Light and utility poles with a diameter less than 12 inches.*
 - b. *Trees less than six inch d.b.h., approved as a part of the Stage II Site Design, or administrative review.*
 - c. *Except as allowed by b., above, an existing tree, trimmed to the trunk, ten feet above the curb.*
 - d. *Official warning or street sign.*
 - e. *Natural contours where the natural elevations are such that there can be no cross-visibility at the intersection and necessary excavation would result in an unreasonable hardship on the property owner or deteriorate the quality of the site.*
- F. *Vertical clearance - a minimum clearance of 12 feet above the pavement surface shall be maintained over all streets and access drives.*

Response: Clear vision areas will be maintained at the corner of each property.

- G. *Interim improvement standard. It is anticipated that all existing streets, except those in new subdivisions, will require complete reconstruction to support urban level traffic volumes. However, in most cases, existing and short-term projected traffic volumes do not warrant improvements to full Master Plan standards. Therefore, unless otherwise specified by the Development Review Board, the following interim standards shall apply.*
1. *Arterials 24 foot paved, with standard sub-base. Asphalt overlays are generally considered unacceptable, but may be considered as an interim improvement based on the recommendations of the City Engineer, regarding adequate structural quality to support an overlay.*
 2. *Half-streets are generally considered unacceptable. However, where the Development Review Board finds it essential to allow for reasonable development, a half-street may be approved. Whenever a half-street improvement is approved, it shall conform to the requirements in the Public Works Standards:*
 3. *When considered appropriate in conjunction with other anticipated or scheduled street improvements, the City Engineer may approve street improvements with a single asphalt lift. However, adequate provision must be made for interim storm drainage, pavement transitions at seams and the scheduling of the second lift through the Capital Improvements Plan.*

Response: There are no existing streets within the development site. These standards are not applicable.

- (.03) Sidewalks.** *Sidewalks shall be provided on the public street frontage of all development. Sidewalks shall generally be constructed within the dedicated public right-of-way, but may be located outside of the right-of-way within a public easement with the approval of the City Engineer.*
- A. *Sidewalk widths shall include a minimum through zone of at least five feet. The through zone may be reduced pursuant to variance procedures in Section 4.196, a waiver pursuant to Section 4.118, or by authority of the City Engineer for reasons of traffic operations, efficiency, or safety.*
 - B. *Within a Planned Development, the Development Review Board may approve a sidewalk on only one side. If the sidewalk is permitted on just one side of the street, the owners*

will be required to sign an agreement to an assessment in the future to construct the other sidewalk if the City Council decides it is necessary.

Response: As shown on Sheet C1.20, all street cross sections within the development site include sidewalks with at least 5 ft. wide. No adjustments are requested. These standards are met.

(.04) *Bicycle Facilities.* *Bicycle facilities shall be provided to implement the Transportation System Plan, and may include on-street and off-street bike lanes, shared lanes, bike boulevards, and cycle tracks. The design of on-street bicycle facilities will vary according to the functional classification and the average daily traffic of the facility.*

Response: The proposed street cross-sections shown on Sheet C1.20 comply with the street classifications and cross-sections identified in the Frog Pond West Master Plan. SW Frog Pond Lane and proposed SW Windflower Street are Local classified streets, and no bike lanes are proposed; bikes will share the vehicular lane with vehicles in these local streets. These standards are met.

(.05) *Multiuse Pathways.* *Pathways may be in addition to, or in lieu of, a public street. Paths that are in addition to a public street shall generally run parallel to that street, and shall be designed in accordance with the Public Works Standards or as specified by the City Engineer. Paths that are in lieu of a public street shall be considered in areas only where no other public street connection options are feasible, and are subject to the following standards.*

- A. *Paths shall be located to provide a reasonably direct connection between likely pedestrian and bicyclist destinations. Additional standards relating to entry points, maximum length, visibility, and path lighting are provided in the Public Works Standards.*
- B. *To ensure ongoing access to and maintenance of pedestrian/bicycle paths, the City Engineer will require dedication of the path to the public and acceptance of the path by the City as public right-of-way; or creation of a public access easement over the path.*

Response: A multiuse path is proposed through Tract A, connecting to proposed SW Windflower Street. The path is part of the Boeckman Creek Trail and is not proposed in lieu of a public street. Therefore, no dedication is required or proposed for the path/trail.

(.06) *Transit Improvements*

Transit Improvements. Development on sites that are adjacent to or incorporate major transit streets shall provide improvements as described in this section to any bus stop located along the site's frontage, unless waived by the City Engineer for reasons of safety or traffic operations. Transit facilities include bus stops, shelters, and related facilities. Required transit facility improvements may include the dedication of land or the provision of a public easement.

[...]

Response: The site is not adjacent to nor incorporates a major transit street. These standards are not applicable.

(.07) *Residential Private Access Drives.* *Residential Private Access Drives shall meet the following standards:*

- A. *Residential Private Access Drives shall provide primary vehicular access to no more than four residential lots.*

Response: Tract B is proposed as a private access/emergency turn-around. Tract B may provide access to only one lot (Lot 9). This standard is met.

B. The design and construction of a Residential Private Access Drive shall ensure a useful lifespan and structural maintenance schedule comparable, as determined by the City Engineer or City's Authorized Representative, to a local street constructed in conformance to current public works standards.

- 1. The design of residential private access drives shall be stamped by a professional engineer registered in the state of Oregon and shall be approved by the City Engineer or City's Authorized Representative to ensure the above requirement is met.*
- 2. Prior to issuing a certificate of occupancy for any residential dwelling unit whose primary vehicular access is from a Residential Private Access Drive the City Engineer or City's Authorized Representative shall certify construction of the Residential Private Access Drive substantially conforms the design approved by the City Engineer or City's Authorized Representative.*

Response: Sheet C1.20 includes a cross section for the proposed private access drive (SW Frog Pond Lane) to be reviewed and approved by City Engineering or Authorized Representative. This standard is intended to be met via this proposal.

C. Residential Private Access Drives shall be named for addressing purposes. All

Residential Private Access Drives shall use the suffix "Lane", i.e. SW Oakview Lane.

D. Residential Private Access Drives shall meet or exceed the standards for access drives and travel lanes established in Subsection (.08) of this Section.

[Amended by Ord. 682, 9/1/10]

Response: The proposed private access drive is to be named SW Frog Pond Lane in accordance with the development code standards. Sheet C1.20 includes a cross section for of the proposed access drive (SW Frog Pond Lane) to be reviewed and approved by City Engineering or Authorized Representative. This standard is intended to be met via this proposal.

(.08). Access Drive and Driveway Approach Development Standards.

- A. An access drive to any proposed development shall be designed to provide a clear travel lane free from any obstructions.*
- B. Access drive travel lanes shall be constructed with a hard surface capable of carrying a 23-ton load.*
- C. Where emergency vehicle access is required, approaches and driveways shall be designed and constructed to accommodate emergency vehicle apparatus and shall conform to applicable fire protection requirements. The City may restrict parking, require signage, or require other public safety improvements pursuant to the recommendations of an emergency service provider.*
- D. Secondary or emergency access lanes may be improved to a minimum 12 feet with an all-weather surface as approved by the Fire District. All fire lanes shall be dedicated easements.*

Response: Sheet C1.20 includes a cross section for the proposed private access drive (SW Frog Pond Lane) to be reviewed and approved by City Engineering or Authorized Representative. Sheet C1.20 includes a Local Road Pavement Section that details the engineering of the intended pavement to be used throughout the proposed development including the private access drive SW Frog Pond Lane. Appendix E includes communication

form the Tualatin Valley Fire & Rescue that the proposal does not include any changes that would require updates to the approved Service Provider Permit.

[...]

- P. *Unless constrained by topography, natural resources, rail lines, freeways, existing or planned or approved development, or easements or covenants, driveways proposed as part of a residential or mixed-use development shall meet local street spacing standards and shall be constructed to align with existing or planned streets, if the driveway.*
1. *Intersects with a public street that is controlled, or is to be controlled in the planning period, by a traffic signal;*
 2. *Intersects with an existing or planned arterial or collector street; or*
 3. *Would be an extension of an existing or planned local street, or of another major driveway.*

Response: Locations of driveways within the subdivision are provided on [Sheet C1.10](#) as conceptual locations. Driveway locations will be verified at the time of building permit review.

(.09) Minimum street intersection spacing standards.

- A. *New streets shall intersect at existing street intersections so that centerlines are not offset. Where existing streets adjacent to a proposed development do not align properly, conditions shall be imposed on the development to provide for proper alignment.*
- B. *Minimum intersection spacing standards are provided in Transportation System Plan Table 3-2.*

Response: The development abuts SW Frog Pond Lane, a Local classified street, and will construct one Local classified street (SW Windflower Street) within the site. All residential lots proposed with this development are accessed from Local streets. Where SW Windflower Street connects to SW Frog Pond Lane, the centerlines are not offset. This standard is met.

- (.10) Exceptions and Adjustments.** *The City may approve adjustments to the spacing standards of subsections (.08) and (.09) above through a Class II process, or as a waiver per Section 4.118(.03)(A.), where an existing connection to a City street does not meet the standards of the roadway authority, the proposed development moves in the direction of Code compliance, and mitigation measures alleviate all traffic operations and safety concerns. Mitigation measures may include consolidated access (removal of one access), joint use driveways (more than one property uses same access), directional limitations (e.g., one-way), turning restrictions (e.g., right in/out only), or other mitigation.*

Response: The proposed street is designed to be in conformance to the Frog Pond West Master Plan; no exceptions or adjustments to the spacing standards are requested.

J. Section 4.180. Exceptions and Modifications - Projections into Required Yards.

- (.01)** *Certain non-structural architectural features are permitted to project into required yards or courts, without requiring the approval of a Variance or Reduced Setback Agreement, as follows:*
- A. *Into any required yard:*
 1. *Architectural features may project into the required yard not more than two (2) inches for each foot of required setback.*

2. Open, unenclosed fire escapes may project a distance not exceeding forty-eight (48) inches.
- B. Into any required yard, adjoining a street or tract with a private drive: [Amended by Ord. 682, 9/9/10]
 1. Architectural features may project a distance not exceeding forty (40) inches.
 2. An uncovered porch, terrace, or patio extending no more than two and one-half (2 1/2) feet above the finished elevation may extend within three (3) feet of an interior side lot line, or within ten (10) feet of a front lot line or of an exterior side lot line.

Response: No buildings are proposed with this application. These provisions are not applicable.

K. Section 4.181. Exceptions & Modifications - Height Limits.

Except as stipulated in Sections 4.800 through 4.804, height limitations specified elsewhere in this Code shall not apply to barns, silos or other farm buildings or structures on farms; to church spires; belfries; cupolas; and domes; monuments; water towers; windmills; chimneys; smokestacks; fire and hose towers; flag poles; above-ground electric transmission, distribution, communication and signal lines, towers and poles; and properly screened mechanical and elevator structures.

Response: No listed structures are proposed at this time. These provisions are not applicable.

L. Section 4.182. Exceptions and Modifications - Setback Modifications.

In any residential zone where the average depth of at least two existing front yards on adjoining lots or within 150 feet of the lot in question and within the same block front is less or greater than the minimum or maximum front yard depth prescribed elsewhere in this Code, the required depth of the front yard on such lot shall be modified. In such case, the front yard depth shall not be less than the average depth, nor more than the greater depth, of existing front yards on at least two adjoining lots within 150 feet. In the case of a corner lot, the depth of the front yard may be reduced to that of the lot immediately adjoining, provided, however, that the depth of a front yard on any corner lot shall be at least ten feet.

Response: No setback modifications are requested under the provisions of this section. These provisions are not applicable.

M. Section 4.197. Zone Changes and Amendments To This Code – Procedures.

- (.01) *The following procedure shall be followed in applying for an amendment to the text of this Chapter:[...]*

Response: No zoning text amendments are proposed. This procedure is not applicable.

- (.02) *The following procedures shall be followed for zone map amendments.*

Response: An amendment to the zoning map is not proposed as part of this project. Therefore, the criteria is not applicable. DB22-0002 Frog Pond Overlook, recommended approval by DRB (resolution 407) and subsequent approval by CC (Ordinance 868), included a Zone Map

Amendment (ZONE22-0002) approval. The proposed middle housing land division will not affect the findings of the Zone Map Amendment (ZONE22-0002) approval.

5. Land Divisions

A. Section 4.210. Application Procedure.

- (.01) Pre-application conference.** *Prior to submission of a tentative condominium, partition, or subdivision plat, a person proposing to divide land in the City shall contact the Planning Department to arrange a pre-application conference as set forth in Section 4.010.*
- A. *Preparation of Tentative Plat. The Planning staff shall provide information regarding procedures and general information having a direct influence on the proposed development, such as elements of the Comprehensive Plan, existing and proposed streets, roads and public utilities. The applicant shall cause to be prepared a tentative plat, together with improvement plans and other supplementary material as specified in this Section. The Tentative Plat shall be prepared by an Oregon licensed professional land surveyor or engineer. An affidavit of the services of such surveyor or engineer shall be furnished as part of the submittal.*
- B. *Tentative Plat Submission. The purpose of the Tentative Plat is to present a study of the proposed subdivision to the Planning Department and Development Review Board and to receive approval or recommendations for revisions before preparation of a final Plat. The design and layout of this plan plat shall meet the guidelines and requirements set forth in this Code. The Tentative Plat shall be submitted to the Planning Department with the following information:*
1. *Site development application form completed and signed by the owner of the land or a letter of authorization signed by the owner. A preliminary title report or other proof of ownership is to be included with the application form.*
 2. *Application fees as established by resolution of the City Council.*
 3. *Ten copies and one sepia or suitable reproducible tracing of the Tentative Plat shall be submitted with the application. Paper size shall be 18 inch by 24 inch, or such other size as may be specified by the City Engineer.*
 4. *Name of the subdivision. No subdivision name shall duplicate or resemble the name of any other subdivision in Clackamas or Washington County. Names may be checked through the county offices.*
 5. *Names, addresses, and telephone numbers of the owners and applicants, and engineer or surveyor.*
 6. *Date, north point and scale of drawing.*
 7. *Location of the subject property by Section, Township, and Range.*
 8. *Legal road access to subject property shall be indicated as City, County, or other public roads.*
 9. *Vicinity map showing the relationship to the nearest major highway or street.*
 10. *Lots. Dimensions of all lots, minimum lot size, average lot size, and proposed lot and block numbers.*
 11. *Gross acreage in proposed plat.*
 12. *Proposed uses of the property, including sites, if any, for multi-family dwellings, shopping centers, churches, industries, parks, and playgrounds or other public or semi-public uses.*
 13. *Improvements: Statement of the improvements to be made or installed including streets, private drives, sidewalks, lighting, tree planting, and times such improvements are to be made or completed.*

14. *Trees. Locations, types, sizes, and general conditions of all existing trees, as required in Section 4.600.*
 15. *Utilities such as electrical, gas, telephone, on and abutting the tract.*
 16. *Easements: Approximate width, location, and purpose of all existing and proposed easements on, and known easements abutting the tract.*
 17. *Deed Restrictions. Outline of proposed deed restrictions, if any.*
 18. *Written Statement. Information which is not practical to be shown on the maps may be shown in separate statements accompanying the Tentative Plat.*
 19. *If the subdivision is to be a "Planned Development," a copy of the proposed Home Owners Association By-Laws must be submitted at the time of submission of the application. The Tentative Plat shall be considered as the Stage I Preliminary Plan. The proposed By-Laws must address the maintenance of any parks, common areas, or facilities.*
 20. *Any plat bordering a stream or river shall indicate areas subject to flooding and shall comply with the provisions of Section 4.172.*
 21. *Proposed use or treatment of any property designated as open space by the City of Wilsonville.*
 22. *A list of the names and addresses of the owners of all properties within 250 feet of the subject property, printed on self-adhesive mailing labels. The list shall be taken from the latest available property ownership records of the Assessor's office of the affected county.*
 23. *A completed "liens and assessments" form, provided by the City Finance Department.*
 24. *Locations of all areas designated as a Significant Resource Overlay Zone by the City, as well as any wetlands shall be shown on the tentative plat.*
 25. *Locations of all existing and proposed utilities, including but not limited to domestic water, sanitary sewer, storm drainage, and any private utilities crossing or intended to serve the site. Any plans to phase the construction or use of utilities shall be indicated.*
 26. *A traffic study, prepared under contract with the City, shall be submitted as part of the tentative plat application process, unless specifically waived by the Community Development Director.*
- C. *Action on proposed tentative plat:*
[...]
- D. *Land division phases to be shown. Where the applicant intends to develop the land in phases, the schedule of such phasing shall be presented for review at the time of the tentative plat. In acting on an application for tentative plat approval, the Planning Director or Development Review Board may set time limits for the completion of the phasing schedule which, if not met, shall result in an expiration of the tentative plat approval.*
 - E. *Remainder tracts to be shown as lots or parcels. Tentative plats shall clearly show all affected property as part of the application for land division. All remainder tracts, regardless of size, shall be shown and counted among the parcels or lots of the division.*
 - F. *Replats subject to same procedures as new plats. Proposals to replat any previously platted land shall be subject to the same standards and procedures as a new application for tentative plat approval. Except, however, that a replat that proposes the same number of lots or parcels as the originally recorded land division, and that is determined by the Planning Director to create no significant adverse impacts on adjacent properties beyond that of the original division, may be reviewed through Class II Administrative Review procedures.*

Response: The Frog Pond Overlook development was previously approved via DB22-0002. The proposal (DB22-0002) received a recommendation of approval by the DBR (resolution 407) and

subsequent approval from CC (Ordinance 868). This approval included the approval of Tentative Subdivision Plat (SUBD22-0001) for a 12-lot subdivision. The requested middle housing land division will further divide the Frog Pond Overlook into a total of 24 middle housing units. Specifically, the 12 lots within the Frog Pond Overlook revised tentative plat will be further divided to incorporate middle housing units for future development. A pre-application conference was held with the Planning Department on September 16, 2021, for the submittal associated with DB22-0002 Frog Pond Overlook. An informal meeting was held February 27, 2023, with City staff to discuss the proposed middle housing land division and it was determined that the proposal requires a Class II, Middle Housing Land Division to be reviewed administratively and a formal pre-application meeting was not necessary.

B. Section 4.232. - Expedited Land Divisions and Middle Housing Land Divisions.

(.01) Applicants for subdivisions or land partitions may request that their applications be processed as expedited land divisions, pursuant to ORS 197. In order to be processed as an expedited land division, each such request must be filed in writing at the time that the application is filed.

Response: The proposal includes a middle housing land division of the Frog Pond Overlook development. This development was previously approved via DB22-0002 which received a recommendation of approval by the DBR (resolution 407) and subsequent approval from CC (Ordinance 868). This approval included the approval of a Tentative Subdivision Plat (SUBD22-0001) for a 12-lot subdivision which has been submitted for revisions through a separate application that is concurrently being reviewed by the City.

The requested middle housing land division will further divide the Frog Pond Overlook into a total of 24 middle housing units. Specifically, the 12 lots of the Frog Pond Overlook revised tentative plat will be further divided to incorporate middle housing units for future development. As such, the proposal includes a request for an expedited land division for the proposed middle housing land division.

(.02) Additional to the relevant standards and criteria applying to partitions and subdivisions, applications for expedited land divisions shall only be approved where the subject property is in a residential zone and the application includes no requests for waivers or variances from the standards applying to land divisions in the zone.

Response: The Frog Pond Overlook site is located within the Residential Neighborhood (RN) Comprehensive Plan Map designation and RN zone applies to lands within Residential Neighborhood Comprehensive Plan Map designation. Additionally, DB22-0002 Frog Pond Overlook, recommended for approval by DRB (resolution 407) and subsequently approved by CC (Ordinance 868), included a Zone Map Amendment (ZONE22-0002) approval confirming the subject property is within a residential zone. As detailed within this report, no requests for waivers or variances from the standards applying to land divisions in the zone. Standard is met.

(.03) An applicant for a land division may process the land division as a Middle Housing land division if all the following are met:

A. The proposed land division is occupied by Middle Housing or an Accessory Dwelling Unit and the associated primary dwelling;

Response: The requested middle housing land division will further divide the 12-lot Frog Pond Overlook development into a total of 24 middle housing units. Specifically, the 12 lots of the Frog Pond Overlook revised tentative plat will be further divided to incorporate middle housing units for future development. Standard is met.

B. Separate utilities are provided for each dwelling unit within the land division;

Response: Sheet C1.30 details composite utility plans demonstrating separate utility connections are provided for each dwelling unit within the proposed middle housing land division. This standard is met.

C. Easements are provided for each dwelling unit for:

1. *Locating, accessing, replacing and servicing all utilities;*
2. *Pedestrian access from each dwelling unit to a street or private drive;*
3. *Any common areas or shared building elements;*
4. *Any dedicated driveways or parking; and*
5. *Any dedicated common area.*

Response: Sheet C1.30, Prelim. Subdivision Plat & Horizontal Control, illustrate easements associated with the proposed land division. Both detached and attached single-family dwelling units are proposed for the newly created lots; therefore, no easements for common/shared access or utility easements are required for the proposed middle housing. Standards are not applicable.

D. Evidence demonstrates how buildings or structures on a resulting middle housing land division unit will comply with applicable building codes provisions relating to new property lines and, notwithstanding the creation of new middle housing land division units, how structures or buildings located on the newly created middle housing land division units will comply with the Oregon residential specialty code.

Response: Sheet C1.10, Site Plan, includes illustrations detailing building setbacks associated with the proposed middle housing units. Individual dwelling designs and compliance with both building codes and Oregon residential specialty codes will be reviewed at the time of building permit submittal. Appendix D has been included as a visual example of proposed dwellings architecture that has been approved via DB22-0002 Frog Pond Overlook development.

E. Notes are added to the final plat indicating the following:

1. *Further division of the resulting middle housing land division units is prohibited;*
2. *The approval of the middle housing land division is pursuant to ORS 92.010 to 92.192, as applicable.*

Response: Acknowledged. This standard shall be met at time of final plat.

F. The Middle Housing Land Division is not used to create separate units of land for a two, three, or four-Unit Cluster Housing development on either of the following:

1. *On land otherwise divisible through a partition or subdivision to create lots for detached single-family homes; or*
2. *On lots in subdivisions or partitions recorded in the prior 24 month period unless the average size of the resulting land division units, determined by adding the areas of land division units and dividing by the number of land division units, is 60 percent or less of the minimum lot size in the zone.*

Response: The requested middle housing land division does not propose to separate units of land for two, three, or four-unit cluster housing development. The proposed middle housing units include detached and attached single-family dwelling units as shown on Sheet C1.10. Additionally, the average lot size of the proposed 24-middle housing units calculates to an average unit size of 4,233 sq. ft. (101,591 sq. ft. / 24 units) which is less than 60 percent of the minimum lot size established by the RN zone district standard (8,000 X .60 = 4,800). See table below for additional analysis:

Middle Housing Average Lot Area		
Original Lot No.	Middle Housing Lot No.	Middle Housing Lot Area (SF)
1	24	4,179
	23	3,901
2	22	4,020
	21	4,019
3	20	3,897
	19	4,418
4	18	4,286
	17	3,809
5	16	4,037
	15	4,050
6	14	3,935
	13	4,216
7	12	4,245
	11	4,774
8	10	4,422
	9	4,621
9	8	4,735
	7	4,410
10	6	4,723
	5	4,260
11	4	4,266
	3	4,272
12	2	4,032
	1	4,064
Totals	24 units	101,591
Average Lot Area (SF)		4,233

(.04) Provisions of Middle Housing Land Divisions:

- A. A Middle Housing Land Division creates separate units of land for each dwelling unit in a Middle Housing development that could otherwise be built on the lot without a land division or to create a separate unit of land for an Accessory Dwelling Unit.

Response: As detailed within the submitted plans and within this report, the tentative plat includes lots that meet the required development standards of the RN zone district. Additionally, the proposal includes incorporating both detached and attached single-family dwelling units within middle housing units which are both permitted uses in the RN zone district. These standards are met.

- B. *Following a Middle Housing Land Division, the units of land resulting from a Middle Housing Land Division shall collectively be considered a single lot, along with the parent lot, for all but platting and property transfer purposes under City code and state rules and statutes, including, but not limited to, the following purposes:*
1. *Lot standards such as size, setback, lot coverage, and lot width and depth;*
 2. *Definition of unit types (e.g., a two-Unit Cluster Housing development where each unit is on its own land division unit through a Middle Housing Land Division would still be considered two-Unit Cluster Housing rather than single-family units; a duplex would still be considered a duplex rather than townhouses);*
 3. *Allowance of number of Middle Housing units and Accessory Dwelling Units;*
 4. *Compliance with Middle Housing rules and statutes in ORS 197 and OAR 660-046.*

Response: The above provisions have been acknowledged.

- C. *Middle Housing Land Division Units, the units of land resulting from a Middle Housing Division, shall:*
1. *Have exactly one dwelling unit (except for tracts for common space), and*
 2. *Not be further divisible.*

Response: The proposed middle housing units include detached and attached single-family dwelling units as shown on Sheet C1.10. All required final plat notes identified within Section 4.232.03.E will be included.

(.05) Procedures and Requirements for Expedited Land Divisions and Middle Housing Land Divisions.

- A. *Expedited Land Divisions and Middle Housing Land Divisions for new middle housing, shall be subject to the same procedures and requirements as conventional land divisions, with the following exceptions:*
1. *The Planning Director shall have the authority to approve, conditionally approve, or deny tentative plat applications through the Administrative Review procedures of Section 4.035. The Director shall not refer an application for an expedited land division to the Development Review Board for hearing and the Board shall not have the authority to call up the decision of the Director for review.*
 2. *The Director shall render a decision on an expedited land division within 30 days of a complete filing, unless a time extension has been requested by the applicant.*
 3. *Appeals of the decisions of the Director on expedited land divisions shall be heard by a referee who has been retained by the City for the purpose of considering such appeals. Decisions of the referee shall be final and the City Council shall not have the authority to call up such decisions for review.*
 4. *The referee shall render a decision on an expedited land division or middle housing land division appeal within 63 days of a complete filing, unless a time extension has been requested by the applicant.*
- B. *Middle Housing Land Division occupied by existing middle housing or an Accessory Dwelling Unit and the associated primary dwelling shall be subject to the same procedures and requirements as partitions.*

- C. *For either process described in A. and B., an applicant may submit multiple tentative middle housing land divisions within the same recorded subdivision or partition plat as a single application.*
- D. *Notwithstanding Subsections A. and B. above, an applicant may elect to have one or more tentative middle housing land divisions reviewed concurrently with the tentative plat of a subdivision subject to review by the Development Review Board. Such tentative middle housing land divisions shall be shown on separate sheet(s) than the tentative subdivision plat and be clearly identified as being created from one or more lots created by the subdivision.*

Response: The requested Middle Housing Land Division will further divide the Frog Pond Overlook into a total of 24 middle housing units. Specifically, the 12 lots of the Frog Pond Overlook revised tentative plat will be further divided to incorporate middle housing units for future development. As such, Expedited Land Divisions for all proposed Middle Housing Land Divisions have been included within this submission. The above procedures and requirements have been acknowledged and it is the intent of the applicant to adhere to them.

C. Section 4.236. General Requirements - Streets.

- (.01)** *Conformity to the Transportation System Plan. Land divisions shall conform to and be in harmony with the Transportation Systems Plan, the Bicycle and Pedestrian Master Plan, and the Parks and Recreation Master Plan.*

Response: The Frog Pond Overlook development was previously approved via DB22-0002. The proposal (DB22-0002) received a recommendation of approval by the DBR (resolution 407) and subsequent approval from CC (Ordinance 868). This approval included the approval of Tentative Subdivision Plat (SUBD22-0001) for a 12-lot subdivision. The proposed middle housing land division does not propose any changes to the approved street configuration. DB22-0002 staff findings indicated, "As found in other findings in this report, the land division conforms with the Transportation System Plan, Frog Pond West Master Plan, and other applicable plans." As such, it can be understood that the proposed revised tentative plat shall be compliant with the standards of this chapter.

- (.02) Relation to Adjoining Street System.**

- A. *A land division shall provide for the continuation of the principal streets existing in the adjoining area, or of their proper projection when adjoining property is not developed, and shall be of a width not less than the minimum requirements for streets set forth in these regulations. Where, in the opinion of the Planning Director or Development Review Board, topographic conditions make such continuation or conformity impractical, an exception may be made. In cases where the Board or Planning Commission has adopted a plan or plat of a neighborhood or area of which the proposed land division is a part, the subdivision shall conform to such adopted neighborhood or area plan.*
- B. *Where the plat submitted covers only a part of the applicant's tract, a sketch of the prospective future street system of the unsubmitted part shall be furnished and the street system of the part submitted shall be considered in the light of adjustments and connections with the street system of the part not submitted.*
- C. *At any time when an applicant proposes a land division and the Comprehensive Plan would allow for the proposed lots to be further divided, the City may require an arrangement of lots and streets such as to permit a later resubdivision in conformity to the street plans and other requirements specified in these regulations.*

Response: No changes to the approved street configuration are proposed at this time. The proposed street network is designed for future continuation per the Frog Pond West Master Plan. These standards are met.

(.03) *All streets shall conform to the standards set forth in Section 4.177 and the block size requirements of the zone.*

Response: The standards of Section 4.177 are addressed in Section V of this narrative.

(.04) **Creation of Easements.** *The Planning Director or Development Review Board may approve an easement to be established without full compliance with these regulations, provided such an easement is the only reasonable method by which a portion of a lot large enough to allow partitioning into two parcels may be provided with vehicular access and adequate utilities. If the proposed lot is large enough to divide into more than two parcels, a street dedication may be required.*

Response: No street easements are proposed. This standard is not applicable.

(.05) **Topography:** *The layout of streets shall give suitable recognition to surrounding topographical conditions in accordance with the purpose of these regulations.*

Response: The street layout recognizes topographical conditions. This standard is met.

(.06) **Reserve Strips.** *The Planning Director or Development Review Board may require the applicant to create a reserve strip controlling the access to a street. Said strip is to be placed under the jurisdiction of the City Council, when the Director or Board determine that a strip is necessary:*

- A. *To prevent access to abutting land at the end of a street in order to assure the proper extension of the street pattern and the orderly development of land lying beyond the street; or*
- B. *To prevent access to the side of a street on the side where additional width is required to meet the right-of-way standards established by the City; or*
- C. *To prevent access to land abutting a street of the land division but not within the tract or parcel of land being divided; or*
- D. *To prevent access to land unsuitable for building development.*

Response: No reserve strip is proposed. This standard is met.

(.07) **Future Expansion of Street:** *When necessary to give access to, or permit a satisfactory future division of, adjoining land, streets shall be extended to the boundary of the land division and the resulting dead-end street may be approved without a turn-around. Reserve strips and street plugs shall be required to preserve the objective of street extension. Notification that the street is planned for future extension shall be posted on the stub street.*

Response: Proposed SW Windflower Street has been extended to the eastern boundary of the site and is intended for future extension. For that reason, no turnarounds are proposed for these streets. The applicant will comply with any requirements related to signage street extension objectives. This standard is met.

(.08) Existing Streets: *Whenever existing streets adjacent to or within a tract are of inadequate width, additional right-of-way shall conform to the designated width in this Code or in the Transportation Systems Plan.*

Response: Frog Pond Lane to the south of the site is of inadequate width. The tentative plat dedicates 9.5 ft. of additional right-of-way to the street. This standard is met.

(.09) Street Names: *No street names will be used which will duplicate or be confused with the names of existing streets, except for extensions of existing streets. Street names and numbers shall conform to the established name system in the City, and shall be subject to the approval of the City Engineer.*

Response: SW Windflower Street is a new public street and SW Frog Pond Lane is a private access drive that will conform to the City's established name system and will be subject to approval by the City Engineer. This standard is met.

D. Section 4.237. General Requirements – Other.

(.01) Blocks:

- A. *The length, width, and shape of blocks shall be designed with due regard to providing adequate building sites for the use contemplated, consideration of needs for convenient access, circulation, control, and safety of pedestrian, bicycle, and motor vehicle traffic, and recognition of limitations and opportunities of topography.*
- B. *Sizes: Blocks shall not exceed the sizes and lengths specified for the zone in which they are located unless topographical conditions or other physical constraints necessitate larger blocks. Larger blocks shall only be approved where specific findings are made justifying the size, shape, and configuration.*

Response: The Frog Pond Overlook development was previously approved via DB22-0002. The proposal (DB22-0002) received a recommendation of approval by the DBR (resolution 407) and subsequent approval from CC (Ordinance 868). This approval included the approval of Tentative Subdivision Plat (SUBD22-0001) for a 12-lot subdivision. The proposed middle housing land division does not proposed any changes to the approved street and/or block configuration. The length, width, and shape of blocks have been designed in conformance with the Frog Pond West Master Plan and to comply with the standards of Section 4.177. These standards are addressed in section V of this narrative. The site is located within the RN zone and is also subject to the block, access, and connectivity standards of Section 4.127(.10). These standards are met.

(.02) Easements:

- A. *Utility lines. Easements for sanitary or storm sewers, drainage, water mains, electrical lines or other public utilities shall be dedicated wherever necessary. Easements shall be provided consistent with the City's Public Works Standards, as specified by the City Engineer or Planning Director. All of the public utility lines within and adjacent to the site shall be installed within the public right-of-way or easement; with underground services extending to the private parcel constructed in conformance to the City's Public Works Standards. All franchise utilities shall be installed within a public utility easement. All utilities shall have appropriate easements for construction and maintenance purposes.*
- B. *Water courses. Where a land division is traversed by a water course, drainage way, channel or stream, there shall be provided a storm water easement or drainage right-of-way conforming substantially with the lines of the water course, and such further width as*

will be adequate for the purposes of conveying storm water and allowing for maintenance of the facility or channel. Streets or parkways parallel to water courses may be required.

Response: Public utilities are placed within public rights-of-way or within public utility easements (PUE) adjacent to the public streets. The applicant and owner of the east adjacent property entered into an agreement to include a 15-foot waterline easement to service the subject property. The easement will be located on the east adjacent property (7115 SW Frog Pond LN, 31W12D 00800) extending north-south along its west property line.

- (.03) Pedestrian and bicycle pathways.** *An improved public pathway shall be required to transverse the block near its middle if that block exceeds the length standards of the zone in which it is located.*
- A. *Pathways shall be required to connect to a cul-de-sac or to pass through unusually shaped blocks.*
 - B. *Pathways required by this subsection shall have a minimum width of ten feet unless they are found to be unnecessary for bicycle traffic, in which case they are to have a minimum width of six feet.*

Response: The Frog Pond Overlook development was previously approved via DB22-0002. The proposal (DB22-0002) received a recommendation of approval by the DBR (resolution 407) and subsequent approval from CC (Ordinance 868). This approval included the approval of Tentative Subdivision Plat (SUBD22-0001) for a 12-lot subdivision. The proposed middle housing land division does not proposed any changes to the approved street configuration. Pedestrian connections on the subject site are proposed through the recreation area/open space of Tract A and connecting to SW Windflower Street. The proposed design is consistent with the Tentative Subdivision Plat (SUBD22-0001) approval.

- (.04) Tree planting.** *Tree planting plans for a land division must be submitted to the Planning Director and receive the approval of the Director or Development Review Board before the planting is begun. Easements or other documents shall be provided, guaranteeing the City the right to enter the site and plant, remove, or maintain approved street trees that are located on private property.*

Response: Proposed street trees will be located within public right-of-way and additional easements should not be needed. This standard is met.

- (.05) Lot Size and shape.** *The lot size, width, shape and orientation shall be appropriate for the location of the land division and for the type of development and use contemplated. Lots shall meet the requirements of the zone where they are located.*
- A. *In areas that are not served by public sewer, an on-site sewage disposal permit is required from the City. If the soil structure is adverse to on-site sewage disposal, no development shall be permitted until sewer service can be provided.*
 - B. *Where property is zoned or deeded for business or industrial use, other lot widths and areas may be permitted at the discretion of the Development Review Board. Depth and width of properties reserved or laid out for commercial and industrial purposes shall be adequate to provide for the off-street service and parking facilities required by the type of use and development contemplated.*
 - C. *In approving an application for a Planned Development, the Development Review Board may waive the requirements of this section and lot size, shape, and density shall conform to the Planned Development conditions of approval.*

Response: The site is served by public sewer, and no on-site sewage disposal is proposed. The property is zoned for residential purposes and is subject to an application for a Planned Development. The site is located within the RN zone and is subject to the standards of that zone. The proposed lots meet the dimensional standards of the RN zone. These standards are met.

- (.06) Access.** *The division of land shall be such that each lot shall have a minimum frontage on a street or private drive, as specified in the standards of the relative zoning districts. This minimum frontage requirement shall apply with the following exceptions:*
- A. *A lot on the outer radius of a curved street or tract with a private drive, or facing the circular end of a cul-de-sac shall have frontage of not less than 25 feet upon a street or tract with a private drive, measured on the arc.*
 - B. *The Development Review Board may waive lot frontage requirements where in its judgment the waiver of frontage requirements will not have the effect of nullifying the intent and purpose of this regulation or if the Board determines that another standard is appropriate because of the characteristics of the overall development.*

Response: The minimum lot width in the RN zone is 40 ft; as detailed in the response to Section 4.127 and shown on Sheet C1.40, each lot has mean width of at least 40 ft. on a public street. These standards are met.

- (.07) Through lots.** *Through lots shall be avoided except where essential to provide separation of residential development from major traffic arteries or adjacent non-residential activity or to overcome specific disadvantages of topography and orientation. A planting screen easement of at least ten feet, across which there shall be no access, may be required along the line of lots abutting such a traffic artery or other disadvantageous use. Through lots with planting screens shall have a minimum average depth of 100 feet. The Development Review Board may require assurance that such screened areas be maintained as specified in Section 4.176.*

Response: There are no through-lots proposed as a part of this project. This standard is not applicable.

- (.08) Lot side lines.** *The side lines of lots, as far as practicable for the purpose of the proposed development, shall run at right angles to the street or tract with a private drive upon which the lots face.*

Response: Side lot lines are proposed at right angles to the extent practicable. This standard is met.

- (.09) Large lot land divisions.** *In dividing tracts which at some future time are likely to be re-divided, the location of lot lines and other details of the layout shall be such that re-division may readily take place without violating the requirements of these regulations and without interfering with the orderly development of streets. Restriction of buildings within future street locations shall be made a matter of record if the Development Review Board considers it necessary.*

Response: No future development tracts are proposed.

- (.10) Building line.** *The Planning Director or Development Review Board may establish special building setbacks to allow for the future redivision or other development of the property or for other reasons specified in the findings supporting the decision. If special*

building setback lines are established for the land division, they shall be shown on the final plat.

Response: No special building setbacks are proposed.

(.11) *Build-to line.* *The Planning Director or Development Review Board may establish special build to lines for the development, as specified in the findings and conditions of approval for the decision. If special build-to lines are established for the land division, they shall be shown on the final plat.*

Response: There is no maximum setback in the RN zones, and no build-to-lines are proposed.

(.12) *Land for public purposes.* *The Planning Director or Development Review Board may require property to be reserved for public acquisition, or irrevocably offered for dedication, for a specified period of time.*

Response: The City has not identified any requirements for property to be reserved for public acquisition. The development will dedicate right-of-way for the public street network.

(.13) *Corner lots.* *Lots on street intersections shall have a corner radius of not less than ten (10) feet.*

Response: As shown on Sheet C1.40, lots on street intersections have corner radii of at least 20 ft. This standard is met.

E. Section 4.262. Improvements - Requirements.

(.01) *Streets.* *Streets within or partially within the development shall be graded for the entire right-of-way width, constructed and surfaced in accordance with the Transportation Systems Plan and City Public Works Standards. Existing streets which abut the development shall be graded, constructed, reconstructed, surfaced or repaired as determined by the City Engineer.*

(.02) *Curbs.* *Curbs shall be constructed in accordance with standards adopted by the City.*

(.03) *Sidewalks.* *Sidewalks shall be constructed in accordance with standards adopted by the City.*

Response: As shown on Sheets C1.20, streets will be graded, constructed, and surfaced according to the TSP, the cross-sections incorporated into the Frog Pond West Master Plan, and the City's Public Works Standards as modified by the City Engineer. These standards are met.

(.04) *Sanitary sewers.* *Sanitary sewers. When the development is within 200 feet of an existing public sewer main, sanitary sewers shall be installed to serve each lot or parcel in accordance with standards adopted by the City. When the development is more than 200 feet from an existing public sewer main, the City Engineer may approve an alternate sewage disposal system.*

(.05) *Drainage.* *Storm drainage, including detention or retention systems, shall be provided as determined by the City Engineer.*

Response: The proposed development will be served by public sanitary sewer. Storm drainage systems are being provided as outlined in the City's Site Assessment and Planning standards. LIDA facilities are proposed within the Frog Pond Ln street frontage. Appendix B includes a Stormwater Report for the proposed revised tentative plat.

(.06) *Underground utility and service facilities.* All new utilities shall be subject to the standards of Section 4.300 (*Underground Utilities*). The developer shall make all necessary arrangements with the serving utility to provide the underground services in conformance with the City's Public Works Standards.

Response: The standards of Section 4.300 are addressed in Section VII of this narrative. These standards are met.

(.07) *Streetlight standards.* Streetlight standards shall be installed in accordance with regulations adopted by the City.

Response: Streetlights will be installed per the Frog Pond West Master Plan and regulations adopted by the City. Sheet C1.30 identifies locations of streetlights. These standards are met.

(.08) *Street signs.* Street name signs shall be installed at all street intersections and dead-end signs at the entrance to all dead-end streets and cul-de-sacs in accordance with standards adopted by the City. Other signs may be required by the City Engineer.

Response: Street signs will be installed per City standards.

(.09) *Monuments.* Monuments shall be placed at all lot and block corners, angle points, points of curves in streets, at intermediate points and shall be of such material, size and length as required by State Law. Any monuments that are disturbed before all improvements are completed by the developer and accepted by the City shall be replaced to conform to the requirements of State Law.

Response: Monuments will be placed per State, Clackamas County, and City requirements.

(.10) *Water.* Water mains and fire hydrants shall be installed to serve each lot in accordance with City standards.

Response: Water mains and fire hydrants are proposed to serve each lot in accordance with City and Fire Department standards.

6. Underground Utilities

A. Section 4.300. General.

- (.01)** *The City Council deems it reasonable and necessary in order to accomplish the orderly and desirable development of land within the corporate limits of the City, to require the underground installation of utilities in all new developments.*
- (.02)** *After the effective date of this Code, the approval of any development of land within the City will be upon the express condition that all new utility lines, including but not limited to those required for power, communication, street lighting, gas, cable television services and related facilities, shall be placed underground.*
- (.03)** *The construction of underground utilities shall be subject to the City's Public Works Standards and shall meet applicable requirements for erosion control and other environmental protection.*

Response: The proposed development is subject to the requirements of this section.

B. Section 4.320. Requirements.

- (.01) The developer or subdivider shall be responsible for and make all necessary arrangements with the serving utility to provide the underground services (including cost of rearranging any existing overhead facilities). All such underground facilities as described shall be constructed in compliance with the rules and regulations of the Public Utility Commission of the State of Oregon relating to the installation and safety of underground lines, plant, system, equipment and apparatus.*
- (.02) The location of the buried facilities shall conform to standards supplied to the subdivider by the City. The City also reserves the right to approve location of all surface-mounted transformers.*
- (.03) Interior easements (back lot lines) will only be used for storm or sanitary sewers, and front easements will be used for other utilities unless different locations are approved by the City Engineer. Easements satisfactory to the serving utilities shall be provided by the developer and shall be set forth on the plat.*

Response: New utilities will be installed underground in accordance with City and other agency requirements. Sheet C1.30 includes a Composite Utility Plan detailing compliance with the above standards. These standards are met.

7. Conclusion

The requested Expedited Land Division for Middle Housing Land Division for the Frog Pond Overlook development has proven to be consistent with the applicable standards of the City of Wilsonville as well as the project number DB22-0002 which received a recommendation of approval by DRB (resolution 407) and subsequent approval by CC (Ordinance 868). As such, West Hills Land Development LLC respectfully requests approval of the applications presented.



Otak, Inc.
808 SW Third Avenue, Ste. 800
Portland, OR 97204
503. 287. 6825
www.otak.com



EXPIRES: 12/31/2023

STAMP



WEST HILLS
LAND DEVELOPMENT
CONSULTANT

FROG POND OVERLOOK

MIDDLE HOUSING

24 DETACHED SINGLE FAMILY LOTS

CITY OF WILSONVILLE, OREGON

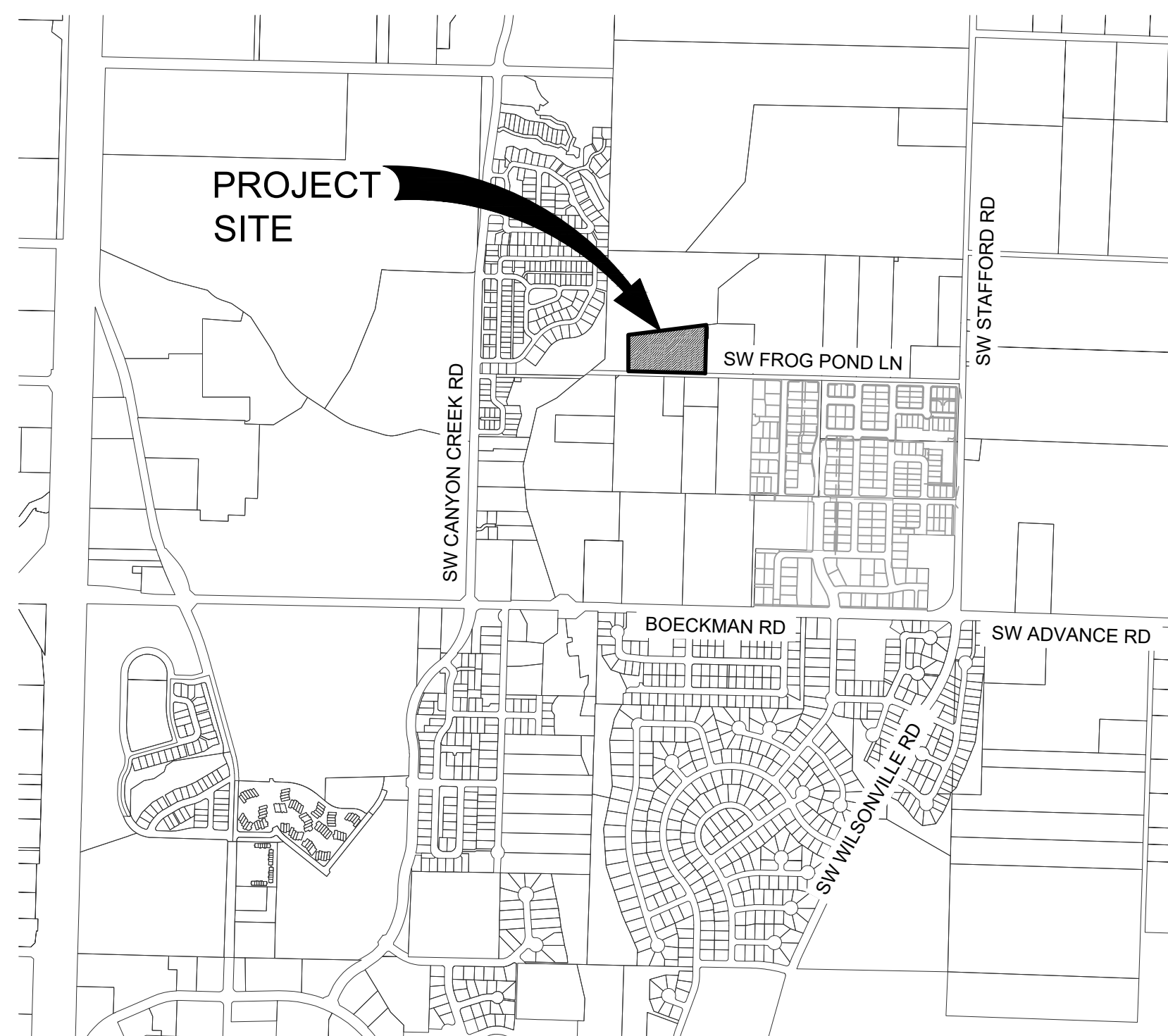

VICINITY MAP
N.T.S.

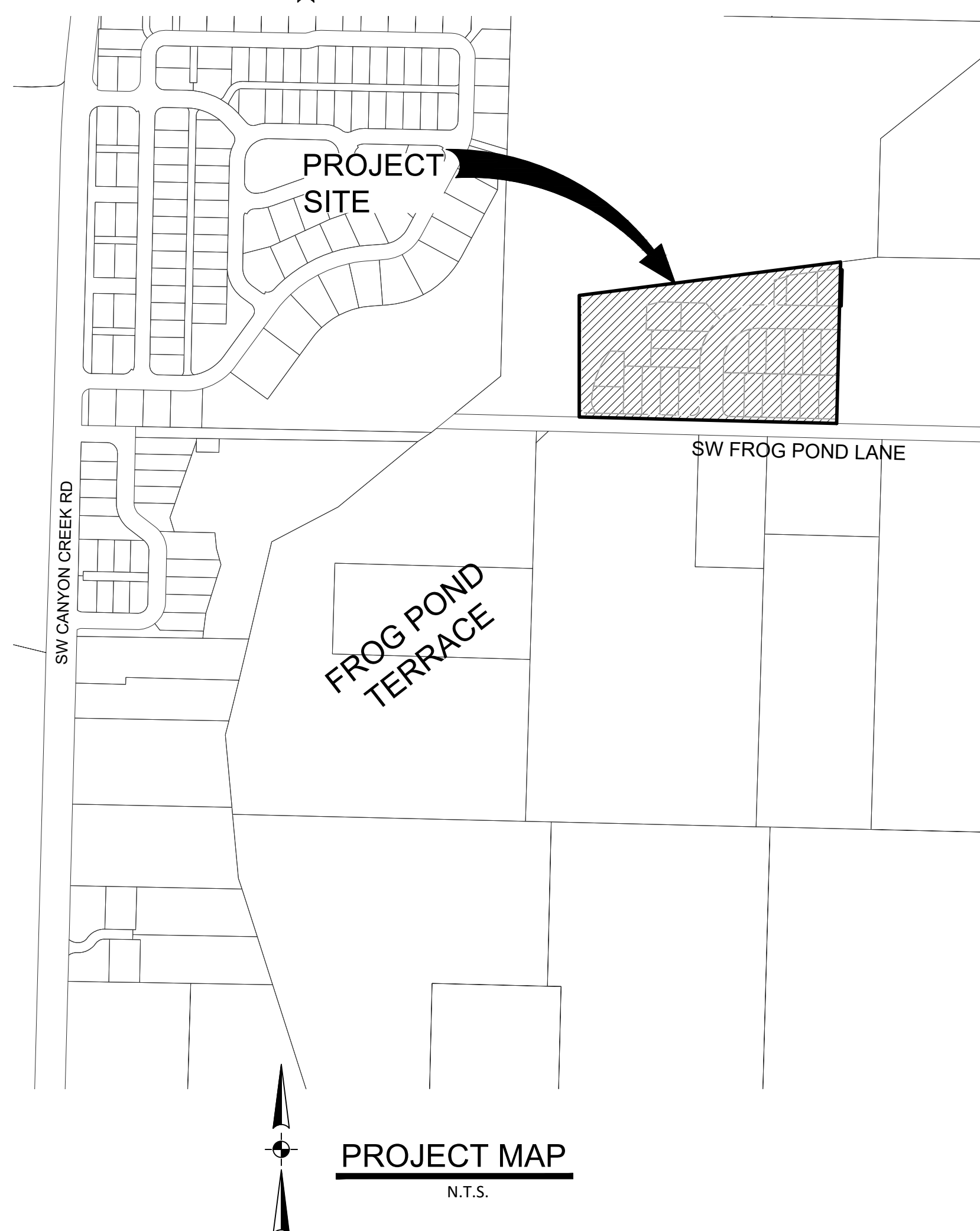

PROJECT MAP
N.T.S.

APPLICANT/ DEVELOPER

NAME: WEST HILLS LAND DEVELOPMENT
CONTACT: DAN GRIMBERG
ADDRESS: 3330 NW YEON AVENUE, SUITE 100
PORTLAND, OR 97210
PHONE: (503) 641-7342

PLANNER /CIVIL ENGINEER/ SURVEYOR/ LANDSCAPE ARCHITECT

NAME: OTAK INCORPORATED
PLANNER: JAMES CRAMER
ENGINEER: KEITH BUISMAN, P.E.
SURVEYOR: MICHAEL SPELTS, PLS
LANDSCAPE ARCHITECT: GABRIEL KRUSE, PLS
ADDRESS: 808 SW THIRD AVENUE, SUITE 800
PORTLAND, OR 97204
PHONE: (503) 287-6825

GEOTECHNICAL ENGINEER

NAME: HARDMAN GEOTECHNICAL SERVICES, INC.
CONTACT: SCOTT HARDMAN, P.E.
ADDRESS: 10110 SW NIMBUS AVENUE, SUITE B-5
PORTLAND, OR 97223
PHONE: (503) 530-8076

ARBORIST

NAME: PORTLAND TREE CONSULTING
CONTACT: PETER TORRES
ADDRESS: PO BOX 19042
PORTLAND, OR 97280
PHONE: (503) 421-3883

NATURAL RESOURCES CONSULTANT

NAME: AKS ENGINEERING & FORESTRY, LLC
CONTACT: STACEY REED, PWS
ADDRESS: 12965 SW HERMAN RD, SUITE 100
TUALATIN, OR 97062
PHONE: (503) 563-6151

BENCHMARK

ELEVATIONS ARE BASED ON GPS CONTROL POINT #6021 BEING A 3" DISK DOWN 0.57" IN A MONUMENT BOX IN PARKWAY AVENUE AT THE WEST 1/4 CORNER OF SECTION 13. PER DATA SHEET PROVIDED BY CITY THE NGVD 29 ELEVATION IS 192.260, WHICH EQUATES TO ELEVATION 195.711 WHEN CONVERTED TO THE PROJECT DATUM OF NAVD 88. UNITS IN INTERNATIONAL FEET.

COORDINATE SYSTEM IS A LOCAL DATUM PLAN BASED ON OREGON STATE PLANE, NORTH ZONE, NAD83 (2011) VALUES SCALED TO GROUND ABOUT COORDINATE 0,0 BY THE INVERSE OF A COMBINED SCALE FACTOR OF 0.999891042 (CALCULATED AT POINT #1.)

STREET LIGHTING

NAME: KITTELSON & ASSOCIATES
CONTACT: ANTHONY YI, P.E.
ADDRESS: 851 SW SIXTH AVE, SUITE 600
PORTLAND, OR 97204
PHONE: (503) 228-5230

GOVERNING JURISDICTION

LAND USE: CITY OF WILSONVILLE
SANITARY SEWER: CITY OF WILSONVILLE
STORM SEWER: CITY OF WILSONVILLE
WATER: CITY OF WILSONVILLE
GRADING: CITY OF WILSONVILLE
EROSION AND SEDIMENT CONTROL: CITY OF WILSONVILLE

FRANCHISE UTILITIES

PGE SUBDIVISION
CONTACT: PENKA TANTILOVA
PHONE: (503) 431-1971
EMAIL: penka.tantilova@pgn.com

PGE STREET LIGHTING
CONTACT: AMBER DRY
PHONE: (503) 736-5627
EMAIL: amber.dry@pgn.com

NW NATURAL
CONTACT: BRIAN KELLEY
PHONE: (503) 220-2427
EMAIL: brian.kelley@nwnatural.com

COMCAST
CONTACT: MIRCEA BURGHELEA
PHONE: (503)798-5785
EMAIL: mircea_burghelea@comcast.com

ZIPLY
CONTACT: LISA CLARK
PHONE: (253) 904-5619
EMAIL: lisa.clark@ziply.com

SITE INFORMATION

CLACKAMAS COUNTY
CITY OF WILSONVILLE, OREGON, 97070

TAXLOT	AREA (AC)
3S 1W 12D 700 (7315 SW FROG POND LANE)	4.07

CALL BEFORE YOU DIG
1-800-332-2344

ATTENTION EXCAVATORS: OREGON LAW REQUIRES COMPLIANCE WITH OAR 952-001-0010 THROUGH OAR 952-001-0090. THESE RULES MAY BE OBTAINED BY CALLING OREGON UTILITY NOTIFICATION CENTER (503) 232-1987. CONTRACTOR MUST NOTIFY THE CENTER AT LEAST TWO WORKING DAYS BEFORE, BUT NOT MORE THAN TEN DAYS BEFORE, COMMENCING EXCAVATION.

SHEET INDEX

SHEET NUMBER	SHEET TITLE
C0.00	COVER SHEET
C1.00	EXISTING CONDITIONS AND DEMO PLAN
C1.10	SITE PLAN
C1.20	STREET CROSS SECTIONS
C1.30	COMPOSITE UTILITY PLAN
C1.40	PRELIM. SUBDIVISION PLAT & HORIZONTAL CONTROL
C2.00	GRADING PLAN
L1.00	TREE PROTECTION PLAN
L1.10	TREE INVENTORY
L2.00	LANDSCAPE PLAN
L2.10	TRACT LANDSCAPE PLAN
L3.00	LANDSCAPE NOTES AND DETAILS

FROG POND OVERLOOK
24 DETACHED SINGLE FAMILY LOTS
CITY OF WILSONVILLE, OREGON
MIDDLE HOUSING

COVER SHEET

TITLE

#	DATE	DESCRIPTION

REVISIONS

NAVD88	DATUM
OTAK CAD	KJB
DRAWN BY	CHECKED BY
LAND USE	STATUS
TBD	DATE
21249	PROJECT NUMBER

C0.00

© 2023 OTAK, INC.

If this drawing is not 22" x 34", it has been reduced/enlarged. Scale accordingly.

Exhibit B2

DEMOLITION NOTES:

- ① DECOMMISSION EXISTING WELL. IT SHALL BE THE RESPONSIBILITY OF THE CONTRACTOR TO CONTACT THE CITY OF WILSONVILLE AND THE STATE OF OREGON WATER MASTER 503-681-7018 TO APPROVE REMOVAL OF ANY EXISTING WATER WELLS.
- ② DECOMMISSION EXISTING SEPTIC TANK. IT SHALL BE THE RESPONSIBILITY OF THE CONTRACTOR TO CONTACT THE CITY OF WILSONVILLE AND THE STATE OF OREGON WATER MASTER 503-681-7018 TO APPROVE THE FILLING OF ANY SEPTIC TANKS.
- ③ DEMOLISH EXISTING BUILDING STRUCTURE. PRE-DEMOLITION PHOTOS OF ALL STRUCTURES MUST BE SUBMITTED WITH THE DEMOLITION PERMIT. A MINIMUM OF 6 PHOTOS FOR EACH STRUCTURE IS REQUIRED. SEE BUILDING DIVISION DEMOLITION POLICY BPP 123 FOR ADDITIONAL DEMOLITION PERMIT REQUIREMENTS.
- ④ REMOVE EXISTING STORM CULVERT.
- ⑤ REMOVE EXISTING FENCE.
- ⑥ PRESERVE AND PROTECT EXISTING OVERHEAD POLES AND LINES.

BENCHMARK

ELEVATIONS ARE BASED ON GPS CONTROL POINT #6021 BEING A 3" DISK DOWN 0.57' IN A MONUMENT BOX IN PARKWAY AVENUE AT THE WEST 1/4 CORNER OF SECTION 13. PER DATA SHEET PROVIDED BY CITY THE NGVD 29 ELEVATION IS 192.260, WHICH EQUATES TO ELEVATION 195.711 WHEN CONVERTED TO THE PROJECT DATUM OF NAVD 88. UNITS IN INTERNATIONAL FEET.

COORDINATE SYSTEM IS A LOCAL DATUM PLAN BASED ON OREGON STATE PLANE, NORTH ZONE, NAD83 (2011) VALUES SCALED TO GROUND ABOUT COORDINATE 0.0 BY THE INVERSE OF A COMBINED SCALE FACTOR OF 0.9999891042 (CALCULATED AT POINT #1.)

EXISTING LEGEND

PROPERTY LINE	---
PROJECT LIMITS	-----
EXISTING 5' CONTOUR	- - - - - 225
EXISTING 5' CONTOUR	- - - - - 221
OVERHEAD LINE	—○—○—○—
FENCE	—x—x—x—
TREE PROTECTION FENCING	—o—o—o—
CULVERT PIPE	—x—x—x—
TREES	⊛ ⊙
TREES TO REMOVE	⊛ ⊙

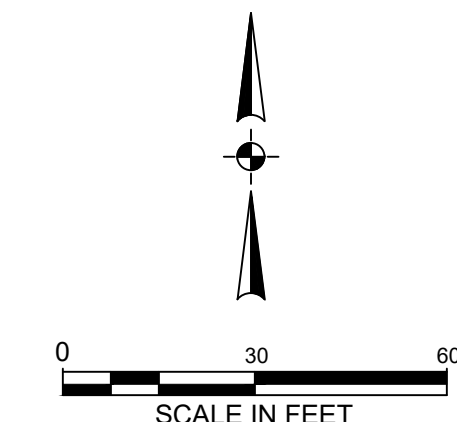
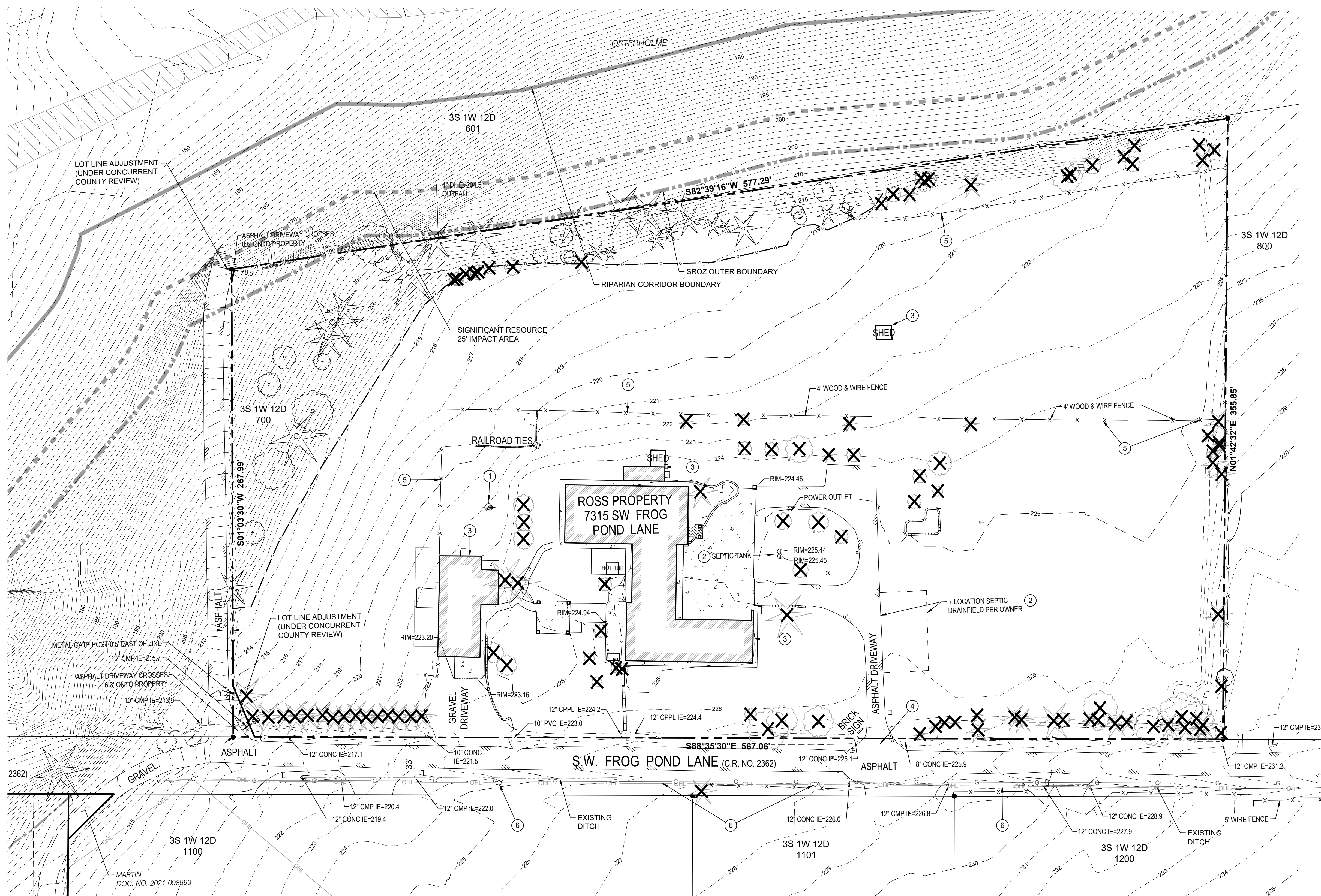

TITLE	DATE	DESCRIPTION

REVISIONS
NAVD88 DATUM
OTAK CAD DRAWN BY
KJB CHECKED BY
LAND USE STATUS
TBD
DATE
21249
PROJECT NUMBER

C1.00
© 2023 OTAK, INC.
If this drawing is not 22" x 34", it has been reduced/enlarged. Scale accordingly.

Plotted: Apr 18, 2023, 10:11am, Mike Haynes, L:\Projects\2120021249\04_CADD\CAD\CAD\Draw\Middle Housing\C1.00.dwg, Layout Name: C1.00

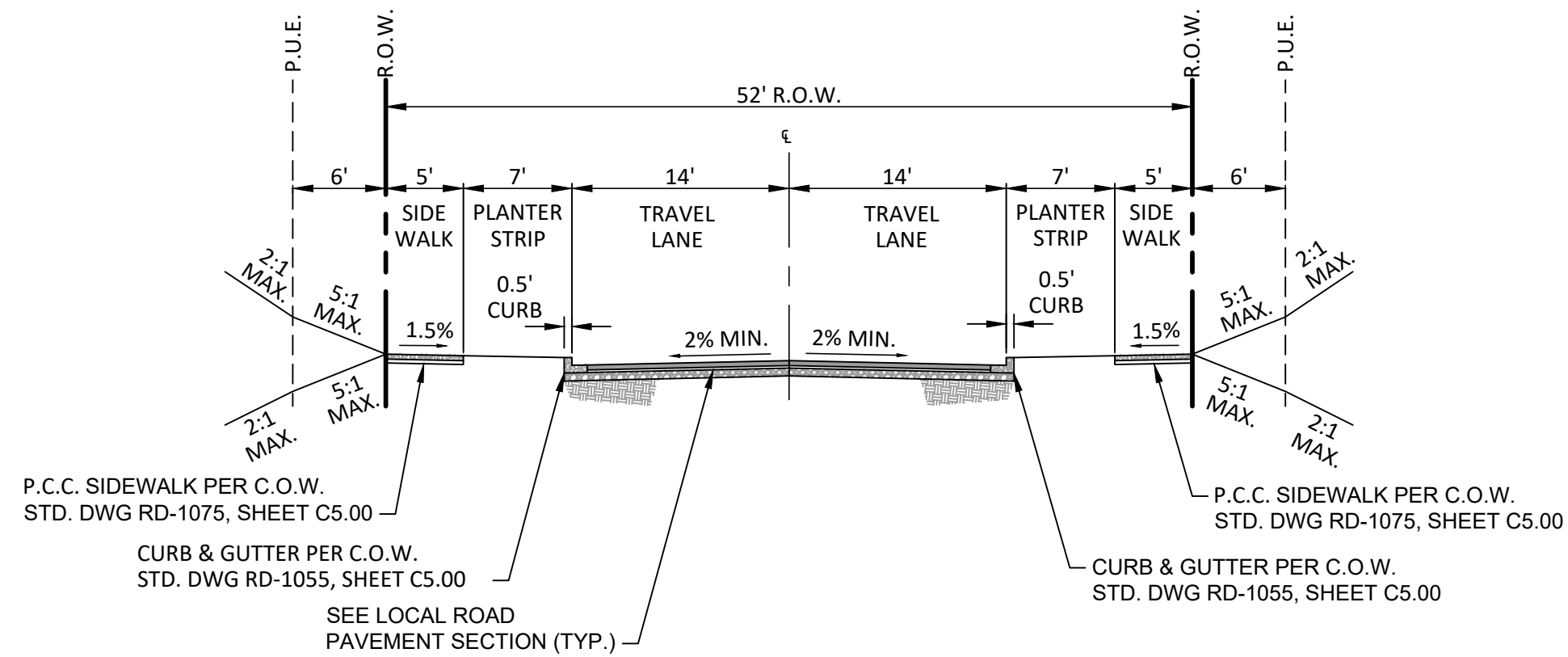

A SW WINDFLOWER ST (STA 10+00 TO 11+93; 12+73 TO 14+87)
(LOCAL STREET - PARKING ON BOTH SIDES)
TOC = CL + 0.17
SCALE: 1" = 10'-0"

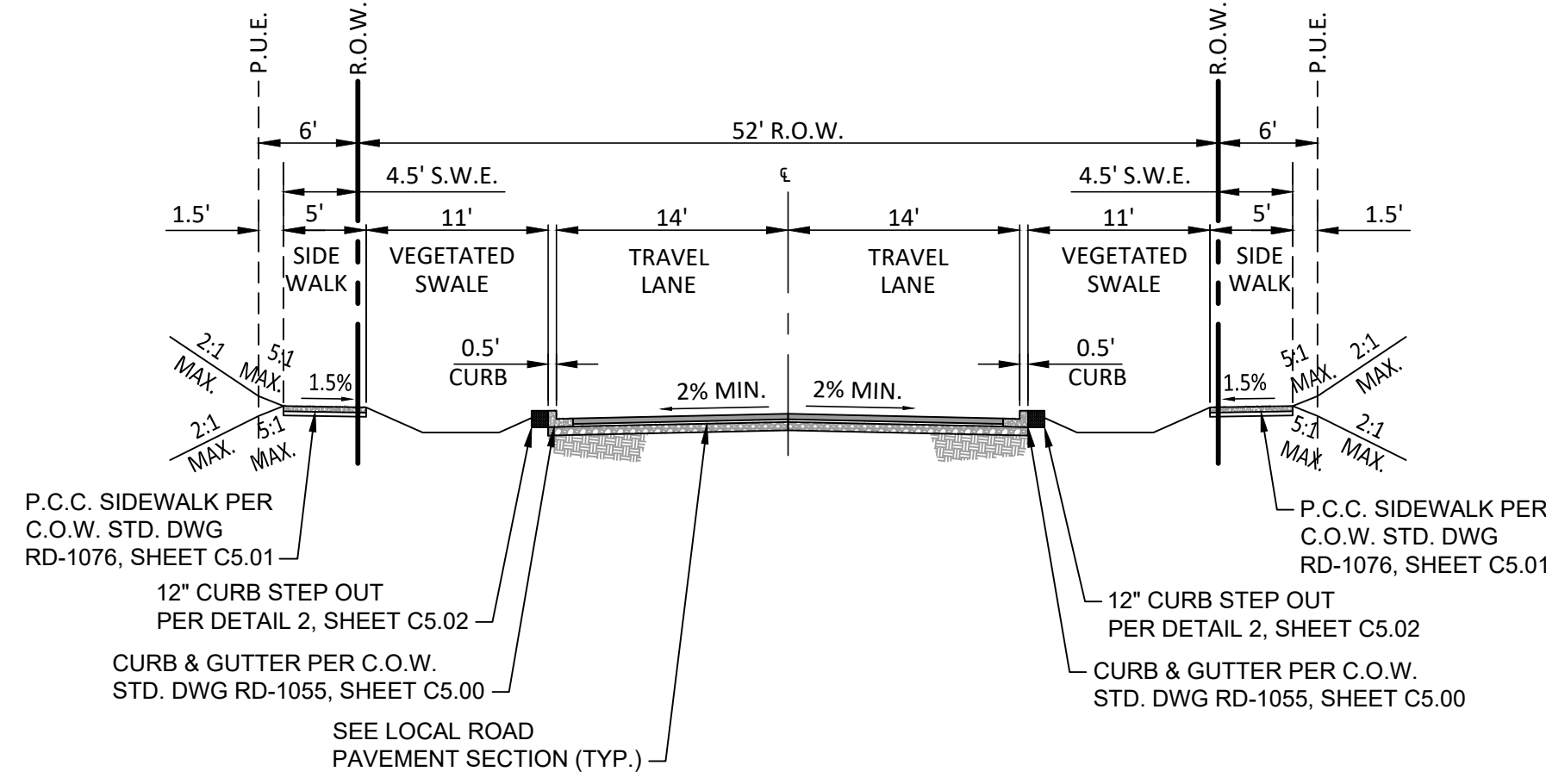

B SW WINDFLOWER ST (STA 11+93 TO 12+73)
(LOCAL STREET - PARKING ON BOTH SIDES)
TOC = CL + 0.17
SCALE: 1" = 10'-0"

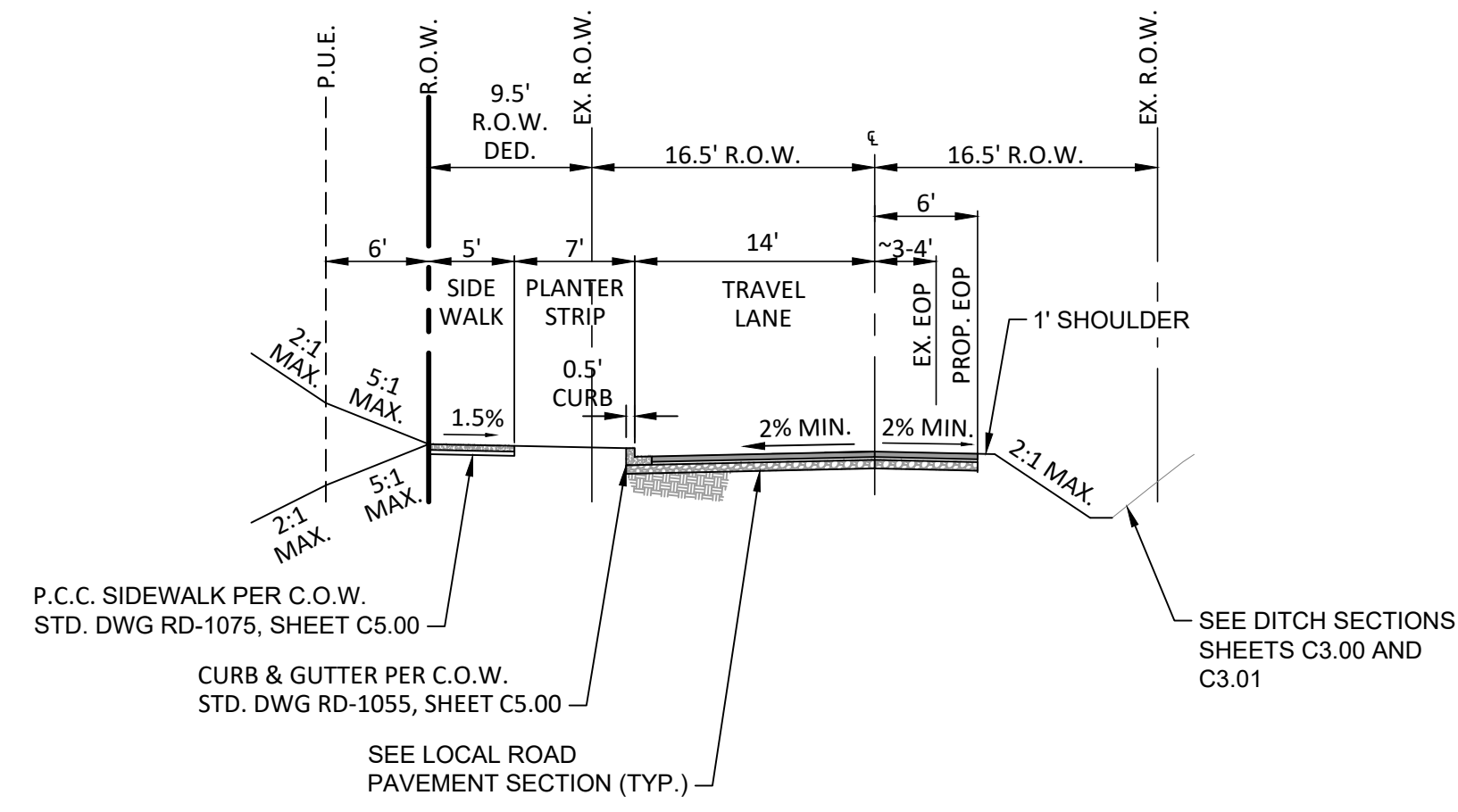

C SW FROG POND LANE (STA 12+57 TO 16+72)
(LOCAL STREET - PARKING ON BOTH SIDES)
TOC LT = CL + 0.17
SCALE: 1" = 10'-0"

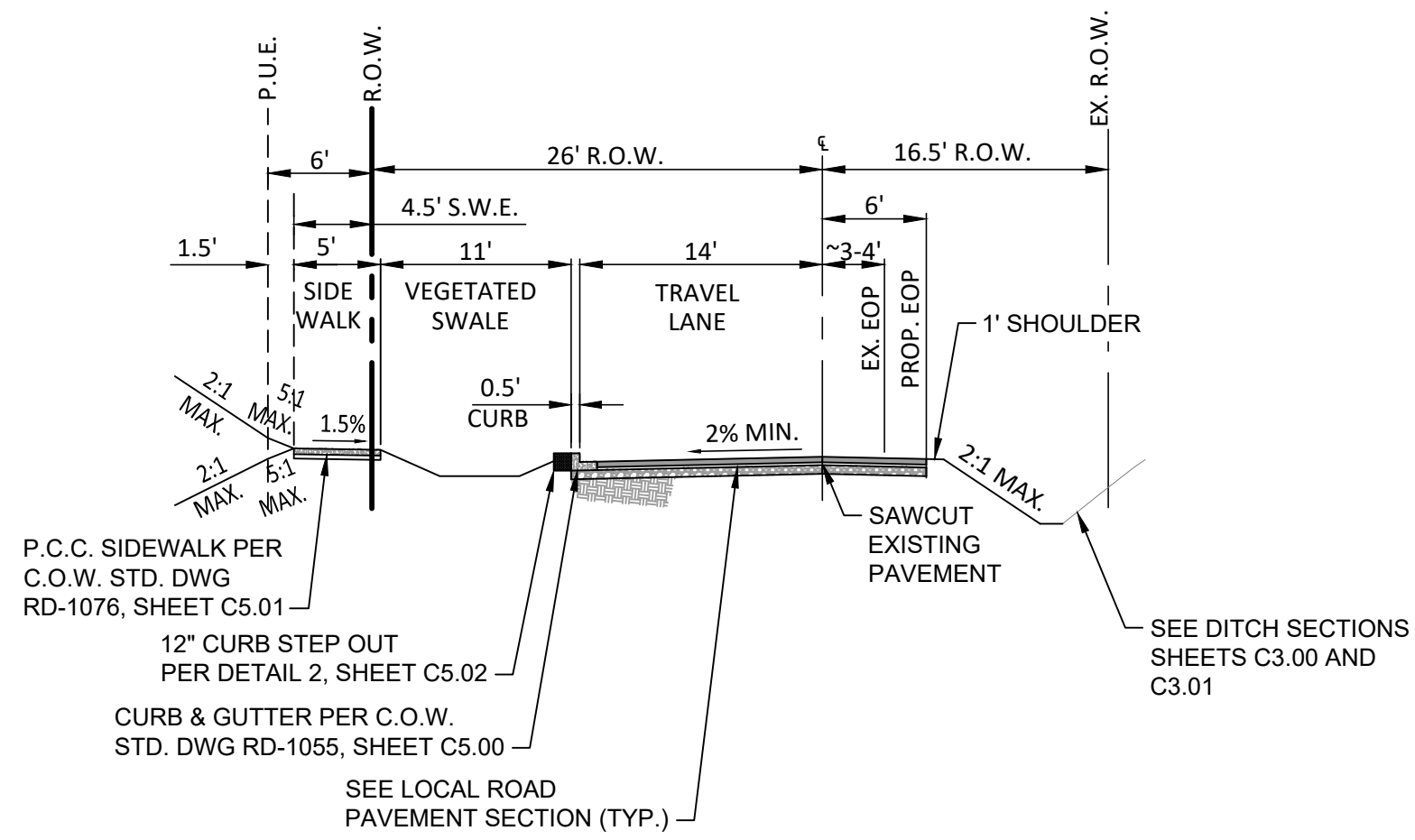

D SW FROG POND LANE (STA 11+72 TO 12+57)
(LOCAL STREET - PARKING ON BOTH SIDES)
TOC LT = CL + 0.17
SCALE: 1" = 10'-0"

GENERAL NOTE:

- FOR PAVEMENT SPECIFICATIONS AND COMPACTION REQUIREMENTS, SEE PAVEMENT SECTION ANALYSIS BY HGSI DATED APRIL 5, 2022.
- WARM MIX AC (WMAC) SHALL BE USED ON ALL PAVEMENT SECTIONS.
- SEE SHEET C1.10 FOR SECTION LOCATIONS.

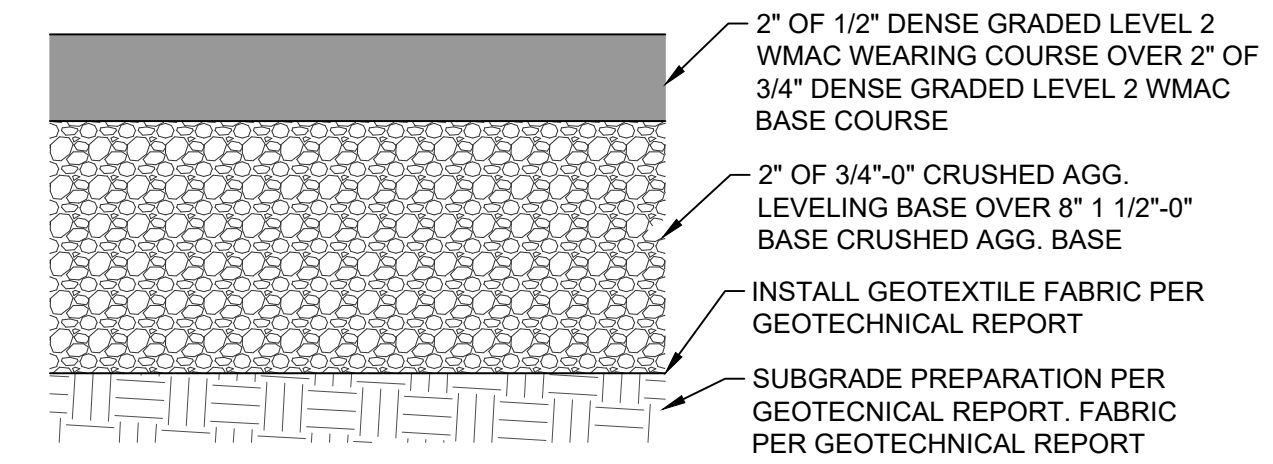

LOCAL ROAD PAVEMENT SECTION
SCALE: NTS

STREET CROSS SECTIONS
SEE SHEET C1.10 FOR SECTION LOCATIONS

FROG POND OVERLOOK
24 DETACHED SINGLE FAMILY LOTS
CITY OF WILSONVILLE, OREGON
MIDDLE HOUSING

STREET CROSS SECTIONS

#	DATE	DESCRIPTION

REVISIONS

NAVDB8
DATUM

OTAK CAD KJB
DRAWN BY CHECKED BY

LAND USE
STATUS

TBD
DATE
21249
PROJECT NUMBER

C1.20

Plotted: Apr 18, 2023, 10:11am, Mike Hawnes, L:\Projects\21200\21249\04_CAD\ACAD\Draw\Middle Housing\C1.20.dwg, Layout Name: C1.20

UTILITY KEY NOTES

- 1 CONNECT TO SANITARY SEWER PROPOSED WITH FROG POND TERRACE.
- 2 CONNECT TO STORM SEWER PROPOSED WITH FROG POND TERRACE.
- 3 CONNECT TO WATER LINE TO BE CONSTRUCTED WITH FROG POND ESTATES. CONNECTION CAN OCCUR WHEN FROG POND ESTATES WATER LINE HAS BEEN INSTALLED, INSPECTED, AND ACCEPTED BY THE CITY.
- 4 PROPOSED VEGETATED SWALE (CITY STD. DWG. ST-6045)
- 5 INSTALL 4-INCH CONDUIT CROSSING FOR NW NATURAL.
- 6 CONNECT TO WATER LINE TO BE CONSTRUCTED WITH FROG POND TERRACE.
- 7 PROPOSED STREET LIGHT - SEE LIGHTING PLANS.
- 8 INSTALL 2-INCH CONDUIT CROSSING FOR PGE.
- 9 INSTALL 3-INCH CONDUIT CROSSING FOR PGE.
- 10 INSTALL (2) 3-INCH CONDUIT CROSSING FOR PGE.

FRANCHISE UTILITY NOTES

1. SEE PGE PLAN M3289142 FOR SUBDIVISION BACKBONE.
2. SEE NW NATURAL GAS PLAN R00029374 FOR SUBDIVISION GAS AND REMOVAL OF GAS LINE IN FROG POND LANE.

LEGEND

SITE	PROPOSED	EXISTING
PROJECT BOUNDARY	---	---
STORM DRAIN MANHOLE	⊙	⊙
STORM DRAIN CLEAN OUT	⊙	⊙
LIDA FLOW CONTROL STRUCTURE (BEEHIVE: CITY STANDARD DWG. ST-6120)	•	
CATCH BASIN	■	
STORM DRAIN MAIN	SD	ST
STORM DRAIN LATERAL	SD	ST
SANITARY SEWER MANHOLE	⊙	⊙
SANITARY SEWER CLEAN OUT	⊙	⊙
SANITARY SEWER MAIN	SS	SA
SANITARY SEWER LATERAL	SS	SA
WATER VALVE	⊕	⊕
WATER BLOW-OFF	⊕	
WATER METER	⊕	
WATER FIRE HYDRANT	⊕	
WATER MAIN	W	WA
WATER LATERAL	W	WA
STREET LIGHT (SEE LIGHTING PLANS IL-1 THROUGH IL-4 FOR DETAILS)	⊕	⊕
PGE VAULT	⊕	

SWALE TABLE

FACILITY	AREA (SF)
SWALE 4	182
SWALE 5	208
SWALE 6	221

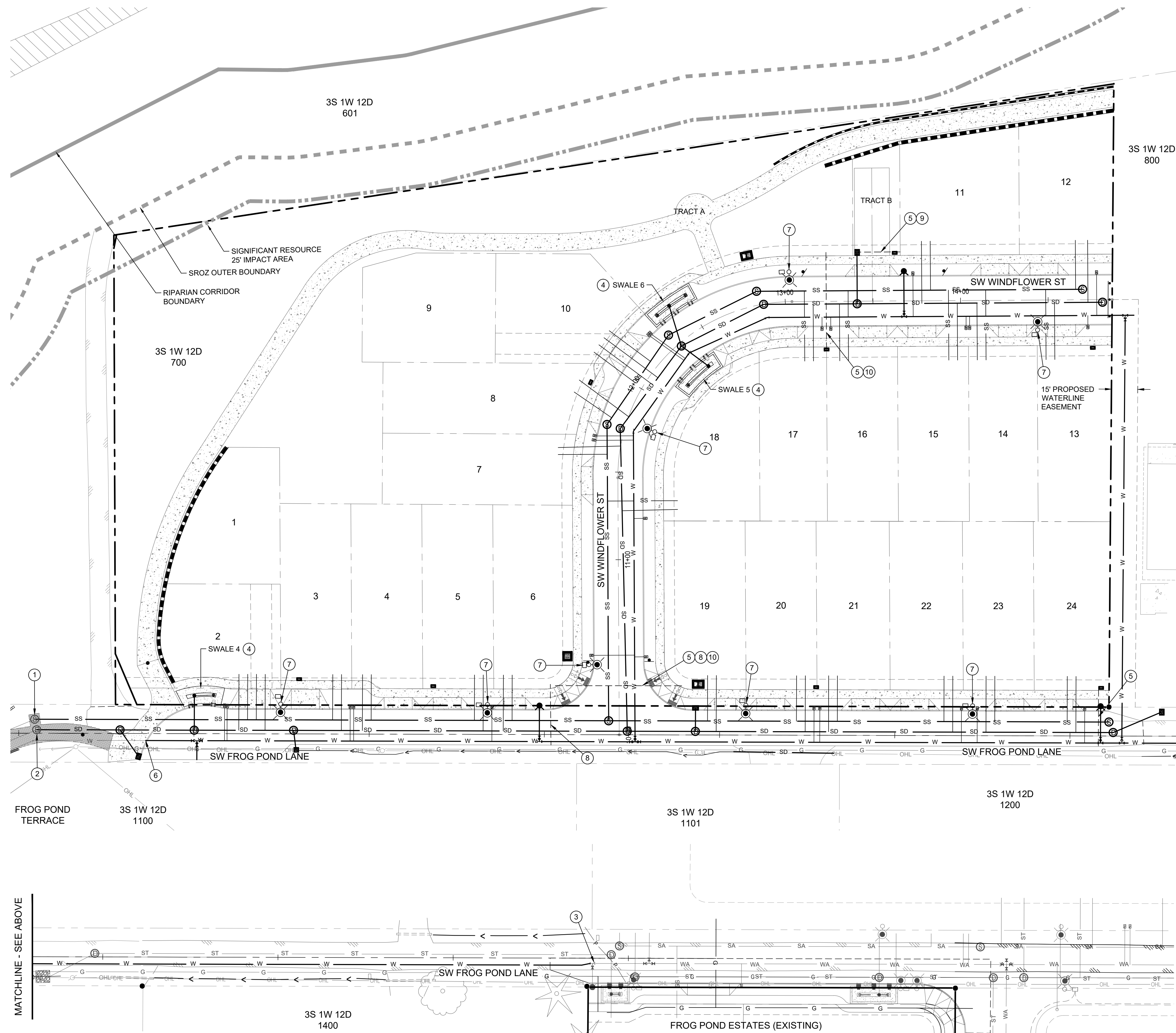

MATCHLINE - SEE BELOW

MATCHLINE - SEE ABOVE

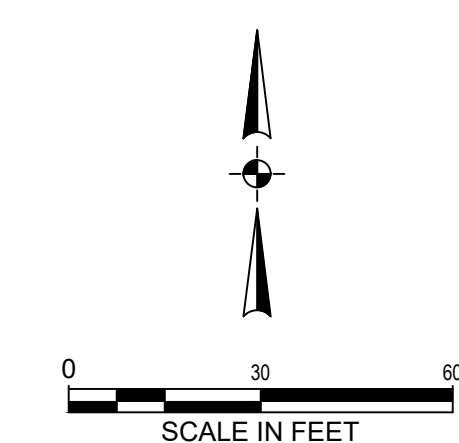

FROG POND OVERLOOK
 24 DETACHED SINGLE FAMILY LOTS
 CITY OF WILSONVILLE, OREGON
MIDDLE HOUSING

COMPOSITE UTILITY PLAN

TITLE	#	DATE	DESCRIPTION

REVISIONS
NAVD88 DATUM
OTAK CAD DRAWN BY
DRAWN BY
CHECKED BY
LAND USE STATUS
TBD
DATE
21249
PROJECT NUMBER

C1.30
© 2023 OTAK, INC.
If this drawing is not 22" x 34", it has been reduced/enlarged. Scale accordingly.



EXPIRES: 12/31/2023

STAMP



WEST HILLS
LAND DEVELOPMENT
CONSULTANT

FROG POND OVERLOOK
24 DETACHED SINGLE FAMILY LOTS
CITY OF WILSONVILLE, OREGON
MIDDLE HOUSING

PRELIM. SUBDIVISION PLAT & HORIZONTAL CONTROL

GENERAL NOTES:

- TRACT A IS FOR OPEN SPACE, PEDESTRIAN ACCESS, AND NATURAL RESOURCE PURPOSES.
- TRACT B IS FOR ACCESS TO LOT 7 AND ALSO INCLUDES A FIRE/SOLID WASTE HAULING TURNAROUND.

TRACT	TYPE
A	NATURAL RESOURCE
B	FIRE/SOLID WASTE HAULING TURNAROUND

LEGEND

RIGHT OF WAY		PROPOSED
CENTER LINE		
LOT LINE		
EASEMENT LINE		
LOT NUMBER		2

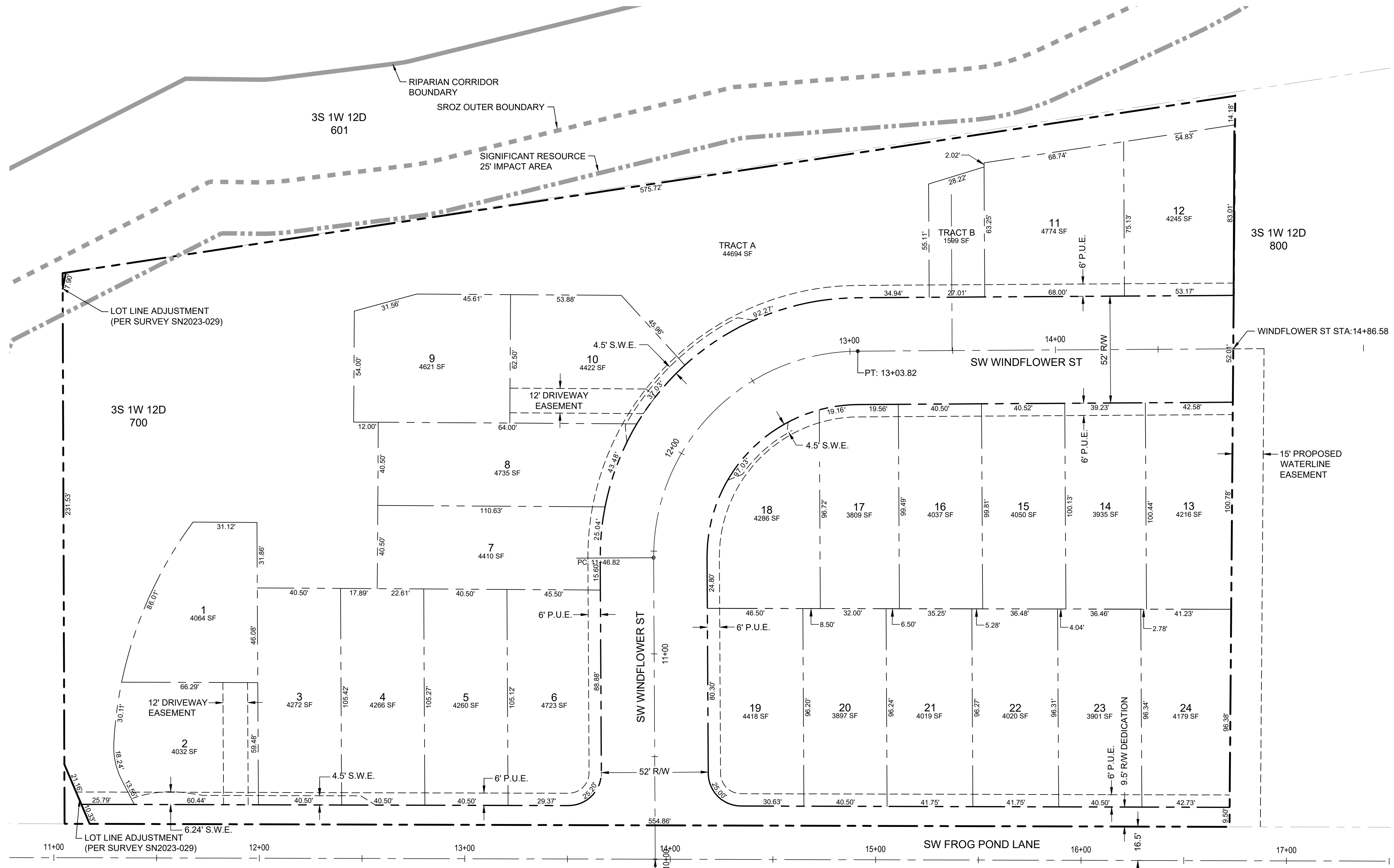

#	DATE	DESCRIPTION

REVISIONS

NAVD88	DATUM
OTAK CAD	KJB
DRAWN BY	CHECKED BY
LAND USE	STATUS
TBD	DATE
21249	PROJECT NUMBER

C1.40

© 2023 OTAK, INC.
If this drawing is not 22" x 34", it has been reduced/enlarged. Scale accordingly.

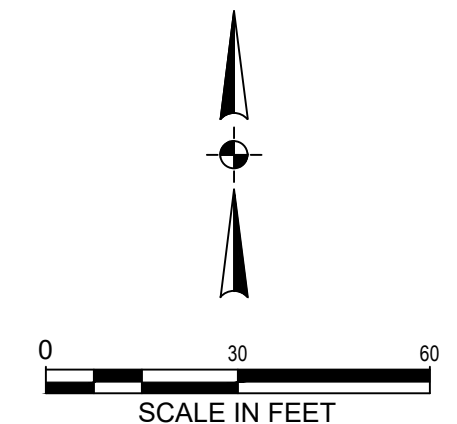

Plotted: Apr 18, 2023, 10:13am, Mike Havens, L:\Projects\21200\21249\04_CAD\CAD\DWG\Middle Housing\C1.40.dwg, Layout Name: C1.40

Plotted: Apr 21, 2023 - 10:26am - Elizabeth Oberlev. L:\Project\21249\04_CAD\CAD\Drawings\Housing\C2149\C200.dwg - Layout Name: C2.00

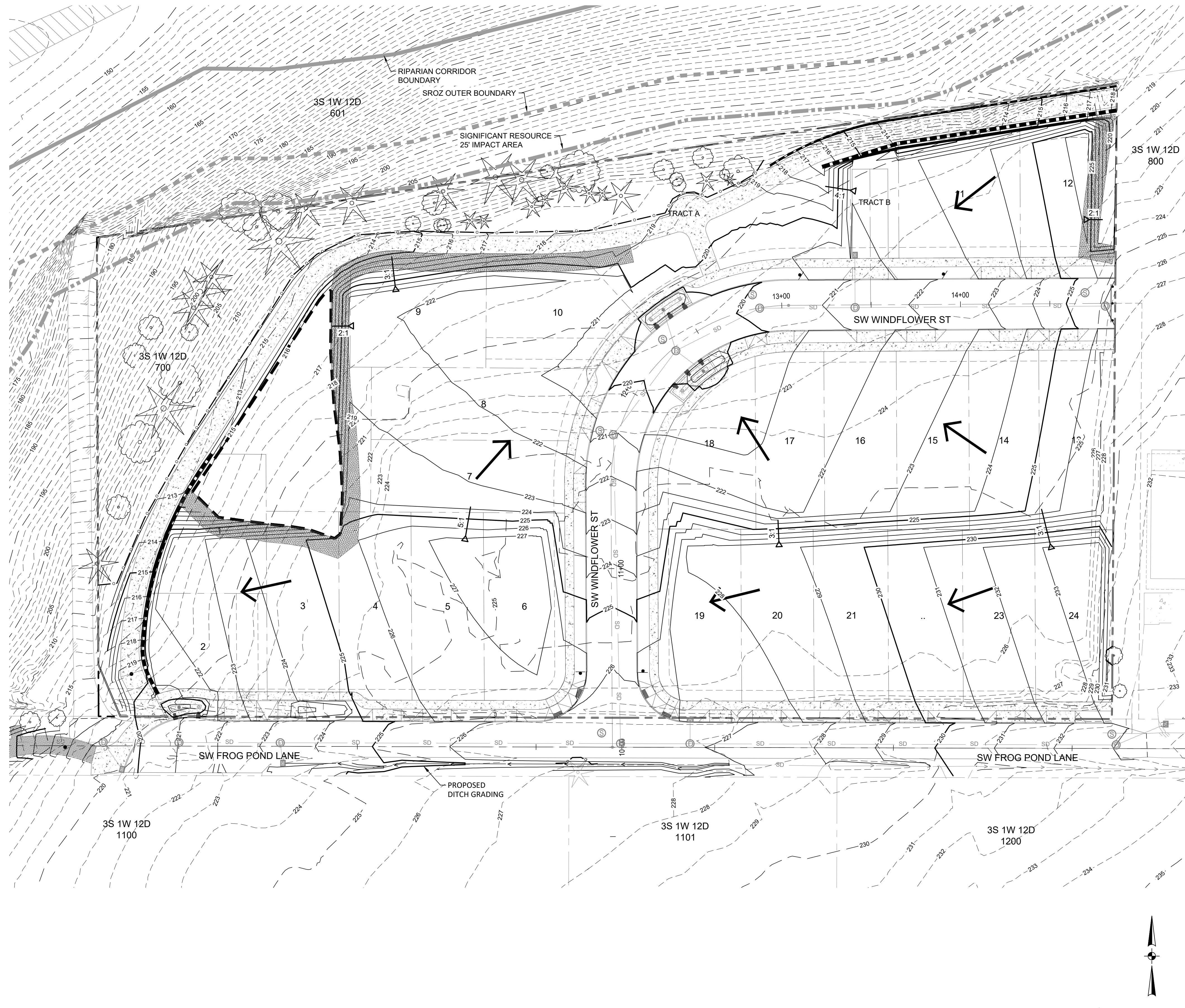

CONSTRUCTION NOTES:

- 1. INSTALL 6-FOOT TALL TREE PROTECTION FENCING PER DETAIL RD-1230, SHEET C5.02.

GRADING NARRATIVE

PROJECT DESCRIPTION:
 THE FROG POND OVERLOOK SUBDIVISION IS A 24-LOT DETACHED SINGLE FAMILY SUBDIVISION.
 GRADING WORK FOR THE FROG POND OVERLOOK SUBDIVISION WILL CONSIST OF THE FOLLOWING:

1. STRIPPING OF EXISTING GROUND (ORGANIC MATERIAL APPROXIMATELY 12" THICK) WITH DISPOSAL OFF-SITE AND SOME STOCKPILING OF STRIPPINGS ON-SITE FOR FUTURE PLACEMENT IN LANDSCAPE AND NON-STRUCTURAL AREAS.
2. ON-SITE EXCAVATION AND EMBANKMENT IS REQUIRED FOR CONSTRUCTION OF PUBLIC STREETS/UTILITIES AND FOR LOT GRADING. STREET AND STRUCTURAL FILLS TO BE CONSTRUCTED IN ACCORDANCE WITH CITY OF WILSONVILLE STANDARDS (SEE NOTES ON C0.10) AND RECOMMENDATIONS IN THE GEOTECHNICAL ENGINEERING REPORT BY HARDMAN GEOTECHNICAL SERVICES, INC.
3. 2H:1V SLOPED AREAS IN SIDEYARDS AND AT BACK OF LOTS MAY BE REPLACED BY BUILDING/FOOTING WALL STRUCTURES DURING HOME CONSTRUCTION. WALLS TO BE PERMITTED AND CONSTRUCTED UNDER SEPARATE BUILDING PERMIT.
4. TRENCH EXCAVATION MATERIAL WILL BE USED FOR ON-SITE FILLS AND/OR HAULED OFF-SITE, DEPENDENT ON THE TIMING OF CONSTRUCTION AND THE QUALITY OF THE TRENCH MATERIAL, AS DETERMINED BY THE GEOTECHNICAL ENGINEER. CONTRACTOR WILL BE RESPONSIBLE FOR ANY REQUIRED PERMITS/APPROVALS FOR MATERIAL DISPOSED OF OFF-SITE.
5. CONSTRUCTION SHALL COMPLY WITH FINDINGS/RECOMMENDATIONS IN "GEOTECHNICAL ENGINEERING AND INFILTRATION TESTING REPORT, FROG POND WEST - WEST" BY HARDMAN GEOTECHNICAL SERVICES INC, DATED: DECEMBER 15, 2021.
6. A GEOTECHNICAL ENGINEERING AND TESTING FIRM WILL BE ON-SITE TO PROVIDE COMPACTION TESTING AND FIELD RECOMMENDATIONS.
7. RETAINING WALL CONSTRUCTION SHALL CONFORM TO DETAILS INCLUDED WITHIN THE GEOTECHNICAL REPORT. THE CONTRACTOR IS TO OBTAIN ALL NECESSARY PERMITS FOR RETAINING WALL CONSTRUCTION.
8. SEE BENCHING DETAIL, FIGURE 4 FROM THE GEOTECH REPORT AND ON SHEET C2.10, FOR FILL SLOPE KEYING AND BENCHING.

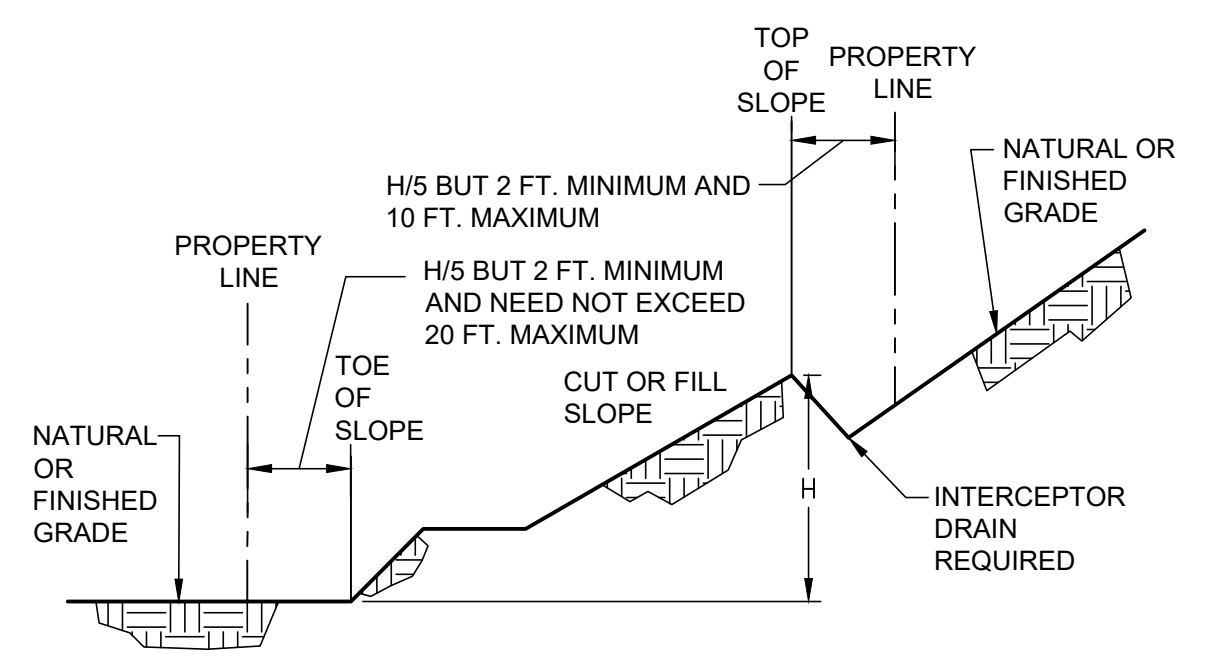

GRADING SETBACKS

(GRADING SETBACK DIMENSION PER 2014 OREGON STRUCTURAL SPECIALTY CODE, APPENDIX J, FIGURE J108.1)

LEGEND

SITE	EXISTING	PROPOSED
1' CONTOUR	--- 221 ---	— 221 —
5' CONTOUR	--- 220 ---	— 220 —
LIMITS OF DISTURBANCE	---	---
RETAINING WALL (KEYNOTE HEIGHT ON LOWSIDE OF WALL)	---	---
LANDSCAPE WALL (HEIGHT = 0'-4")	---	---
PUBLIC LIDA W/CURB OPENINGS	---	---
DRAINAGE FLOW ARROW	←	←
TREES TO REMAIN	○	○
TREE PROTECTION FENCING	○-○-○	○-○-○
FILL SLOPE KEYING AND BENCHING AREAS	---	---

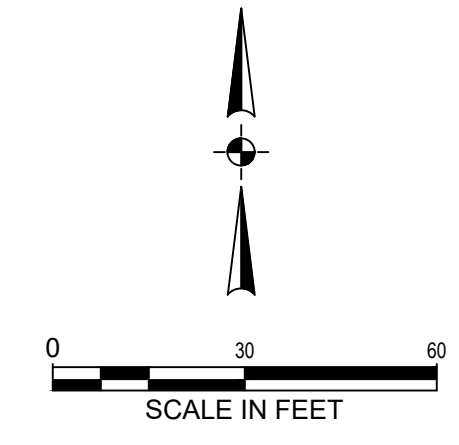

Otak, Inc.
 808 SW Third Avenue, Ste. 800
 Portland, OR 97204
 503.287.6825
 www.otak.com



FROG POND OVERLOOK
 24 DETACHED SINGLE FAMILY LOTS
 CITY OF WILSONVILLE, OREGON
MIDDLE HOUSING
GRADING PLAN

TITLE	#	DATE	DESCRIPTION

REVISIONS
NAVD88 DATUM
OTAK CAD DRAWN BY
KJB CHECKED BY
LAND USE STATUS
TBD
DATE
21249
PROJECT NUMBER

C2.00
 © 2023 OTAK, INC.
 If this drawing is not 22" x 34", it has been reduced/enlarged. Scale accordingly.

TREE PLAN LEGEND

SYMBOL	QTY	DESCRIPTION
	109	EXISTING TREES TO BE REMOVED
	42	EXISTING TREES TO REMAIN
	3	EXISTING OFF-SITE TREES TO BE PROTECTED
	495 LF	TREE PROTECTION FENCING
		TREE PROTECTION FENCING

SEE PLANTING PLAN L2.00 STREET/SITE TREES TO BE PLANTED

NOTES:

- CONTOURS ARE SHOWN FOR ROUGH FINISH GRADE DESIGN ONLY. SEE CIVIL PLANS FOR DETAILED GRADING.
- MITIGATION:
109 TREES REMOVED.
30 TREES PROPOSED (15 STREET TREES AND 15 TREES IN TRACT A).
PAY INTO TREE FUND FOR 79 TREES.

This Detail Drawing may not be altered or changed in any manner except by the City Engineer. It is the responsibility of the user to acquire the most current version.

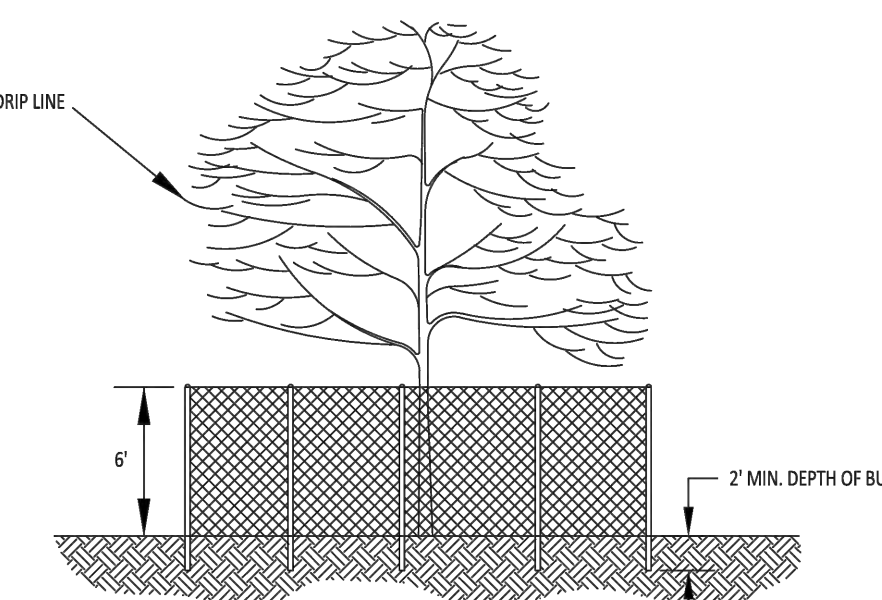

- NOTES:
- FENCE SHALL BE 6' IN HEIGHT AND SET AT TREE DRIP LINE.
 - FENCE MATERIALS SHALL CONSIST OF 2" MESH CHAIN LINKS SECURED TO A MINIMUM 1 1/2" DIA. STEEL OR ALUMINUM LINE POSTS.
 - POSTS SHALL BE SET TO A DEPTH OF NO LESS THAN 2 FEET IN NATIVE SOIL.
 - FENCE SHALL REMAIN IN PLACE UNTIL THE COMPLETION OF CONSTRUCTION ACTIVITIES. MOVEMENT OR REMOVAL OF FENCE REQUIRES APPROVAL BY CITY'S AUTHORIZED REPRESENTATIVE.

Tree Protection Fencing		CITY OF WILSONVILLE
DRAWING NUMBER: RD-1230	DRAWN BY: SR	SCALE: N.T.S.
FILE NAME: RD-1230.DWG	APPROVED BY: NK	DATE: 4/2/14
		PUBLIC WORKS STANDARDS

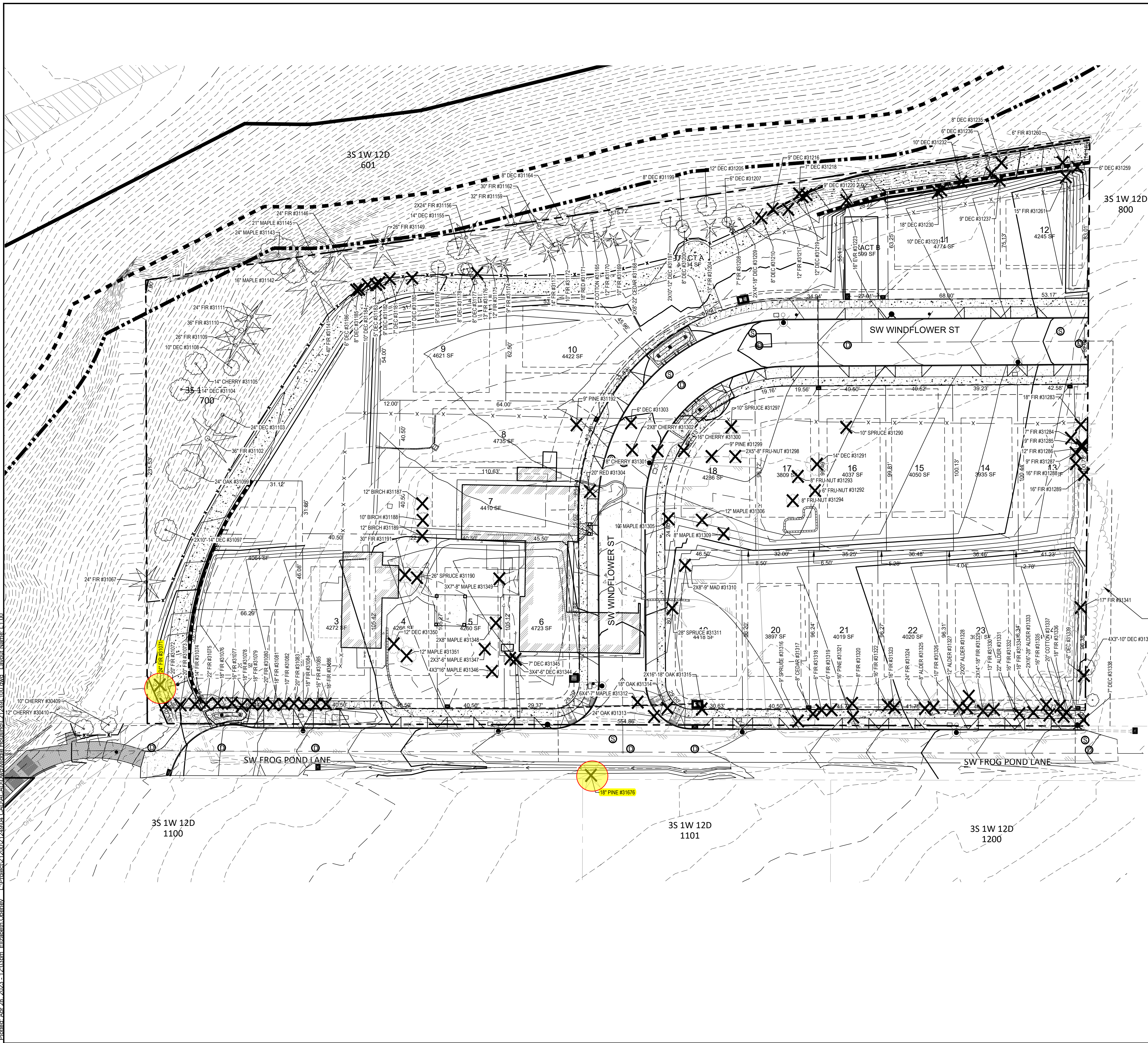

FROG POND OVERLOOK
24 DETACHED SINGLE FAMILY LOTS
CITY OF WILSONVILLE, OREGON
MIDDLE HOUSING

TREE PROTECTION PLAN

TITLE	#	DATE	DESCRIPTION

REVISIONS	
NAVDB8	
DATUM	
OTAK CAD	KJB
DRAWN BY	CHECKED BY
LAND USE	STATUS
TBD	
DATE	
21249	
PROJECT NUMBER	

L1.00
© 2023 OTAK, INC.
If this drawing is not 22" x 34", it has been reduced/enlarged. Scale accordingly.

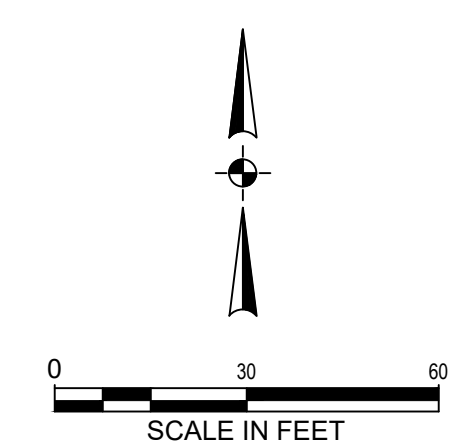



Otak, Inc.
808 SW Third Avenue, Ste. 800
Portland, OR 97204
503.287.6825
www.otak.com

PRELIMINARY



FROG POND OVERLOOK
 24 DETACHED SINGLE FAMILY LOTS
 CITY OF WILSONVILLE, OREGON
MIDDLE HOUSING
TREE INVENTORY

TITLE # DATE DESCRIPTION

REVISIONS
 NAVD88
 DATUM
 OTAK CAD KJB
 DRAWN BY CHECKED BY
 LAND USE
 STATUS
 TBD
 DATE
 21249
 PROJECT NUMBER

L1.10

© 2023 OTAK, INC.
 If this drawing is not 22" x 34", it has been reduced/enlarged. Scale accordingly.

Tag	Species	DBH	Dripline	Rating	Health & Structure	RPZ	Action
30409	Sato Cherry	10"	18	2	assymetric crown - Offsite	10 ft.	Protect
30410	Sato Cherry	12"	18	2	assymetric crown - Offsite		Protect
31067	Douglas-fir	24"	18	2	on a berm, part of windrow; through 31102 crowded trees		Protect
31071	Douglas-fir	24"	12	2	2 stems at 20 ft. Many of these were topped at 30 ft.		Remove
31072	Douglas-fir	20"	12	2	Topped or broken in past; part of windrow		Remove
31073	Douglas-fir	20"	12	2	Topped or broken in past; part of windrow		Remove
31074	Douglas-fir	14"	12	2	Topped or broken in past; part of windrow		Remove
31075	Douglas-fir	22"	12	2	Topped or broken in past; part of windrow		Remove
31076	Douglas-fir	18"	12	2	Topped or broken in past; part of windrow		Remove
31077	Douglas-fir	16"	12	2	Topped or broken in past; part of windrow		Remove
31078	Douglas-fir	18"	12	2	Topped or broken in past; part of windrow		Remove
31079	Douglas-fir	18"	12	2	Topped or broken in past; part of windrow		Remove
31080	Douglas-fir	20"	12	2	Topped or broken in past; part of windrow		Remove
31081	Douglas-fir	18"	12	2	Topped or broken in past; part of windrow		Remove
31082	Douglas-fir	10"	12	2	Topped or broken in past; part of windrow		Remove
31083	Douglas-fir	20"	12	2	Topped or broken in past; part of windrow		Remove
31084	Douglas-fir	18"	12	2	Topped or broken in past; part of windrow		Remove
31085	Douglas-fir	16"	12	2	Topped or broken in past; part of windrow		Remove
31086	Douglas-fir	18"	12	2	Topped or broken in past; part of windrow		Remove
31097	Gary oak	2X10"-14"	18	2	2 trunks from ground		Protect
31099	Gary oak	24"	20	2	2 trunks from ground		Protect
31102	Douglas-fir	36"	20	2	2 trunks from ground		Protect
31103	Gary oak	24"	12	2	assymetric crown		Protect
31104	Gary oak	14"	8	2	leans and assymetric crown		Protect

Portland Tree Consulting Fieldwork done by Peter Torres, PN-0650B, on 1/13/2022 and 1/14/2022

Tag	Species	DBH	Dripline	Rating	Health & Structure	RPZ	Action
31208	Douglas-fir	7"	6	2	assymetric crown		Protect
31209	Scouler willow	2X14"-18"	16	2	the 14" stem is a cottonwood, the 14" stem is Scouler willow		Protect
31210	red alder	8"	12	2	assymetric crown		Remove
31216	red alder	9"	8	2	assymetric crown		Remove
31217	Douglas-fir	12"	10	2	assymetric crown		Remove
31218	red alder	7"	6	2	assymetric crown		Remove
31219	red alder	12"	8	2	assymetric crown		Remove
31220	red alder	9"	6	2	assymetric crown		Remove
31223	Douglas-fir	16"	12	2	assymetric crown		Remove
31230	red alder	18"	12	2	assymetric crown		Remove
31231	red alder	10"	8	2	assymetric crown		Remove
31232	red alder	10"	8	2	assymetric crown		Remove
31235	red alder	8"	8	2	assymetric crown		Remove
31236	red alder	6"	6	2	assymetric crown		Remove
31237	red alder	9"	8	2	assymetric crown		Remove
31259	red alder	6"	6	2	assymetric crown		Remove
31260	Douglas-fir	6"	6	2	assymetric crown		Remove
31261	Douglas-fir	15"	12	2	assymetric crown		Remove
31283	Douglas-fir	18"	12	2	on a berm with shallow roots; assymetric crown		Remove
31284	Douglas-fir	7"	10	2	on a berm with shallow roots; assymetric crown		Remove
31285	Douglas-fir	9"	10	2	on a berm with shallow roots; assymetric crown		Remove
31286	Douglas-fir	12"	12	2	on a berm with shallow roots; assymetric crown		Remove
31287	Douglas-fir	9"	10	2	on a berm with shallow roots; assymetric crown		Remove
31288	Douglas-fir	16"	16	2	on a berm with shallow roots; assymetric crown		Remove

Portland Tree Consulting Fieldwork done by Peter Torres, PN-0650B, on 1/13/2022 and 1/14/2022

Tag	Species	DBH	Dripline	Rating	Health & Structure	RPZ	Action
31341	Douglas-fir	17"	14	2	on a berm with shallow roots		Remove
31344	Portuguese laurel	3X4"-6"	6	2	invasive species		Remove
31345	Portuguese laurel	7"	6	2	invasive species		Remove
31346	Japanese maple	4X3"-16"	8	2	within 10 ft. of building		Remove
31347	Japanese maple	2X3"-6"	8	2	within 10 ft. of building		Remove
31348	Japanese maple	2X8"	8	2	within 10 ft. of building		Remove
31349	Japanese maple	3X7"-8"	8	2	within 10 ft. of building		Remove
31350	Portuguese laurel	12"	8	2	within 10 ft. of building		Remove
31351	Japanese maple	12"	10	1	terminal decline		Remove
31676	ponderosa pine	18"	8	1	topped at 20 ft. for high-voltage lines - Offsite		Remove

Rating: 0/dead or hazardous, 1/decline, 2/average, 3/excellent health and structure

Tag	Species	DBH	Dripline	Rating	Health & Structure	RPZ	Action
31105	sweet cherry	14"	8	2	assymetric crown		Protect
31108	Gary oak	10"	12	2	assymetric crown		Protect
31109	Douglas-fir	26"	16	2	viable		Protect
31110	Douglas-fir	36"	16	2	viable		Protect
31111	Douglas-fir	24"	14	2	forks at 50 ft.		Protect
31141	Douglas-fir	40"	24	2	viable		Protect
31142	bigleaf maple	16"	12	1	ivy-infested		Protect
31143	bigleaf maple	24"	12	1	ivy-infested		Protect
31145	bigleaf maple	21"	12	1	ivy-infested		Protect
31146	Douglas-fir	24"	12	1	ivy-infested		Protect
31149	Douglas-fir	26"	16	2	ivy-infested		Protect
31155	red alder	14"	8	1	broken		Protect
31156	Douglas-fir	2X24"	16	2	ivy-infested		Protect
31159	Douglas-fir	32"	16	2	ivy-infested		Protect
31162	Douglas-fir	30"	16	2	ivy-infested		Protect
31164	red alder	8"	8	2	ivy-infested		Protect
31165	Cottonwood	24"	12	2	ivy-infested		Protect
31168	western redcedar	2X8"-22"	18	2	assymetric crown		Protect
31169	Douglas-fir	10"	6	2	assymetric crown		Protect
31170	Douglas-fir	12"	8	2	assymetric crown		Protect
31171	giant sequoia	18"	10	2	assymetric crown		Protect
31172	Douglas-fir	10"	10	2	assymetric crown		Protect
31173	Douglas-fir	14"	10	2	assymetric crown		Protect
31174	Douglas-fir	9"	8	2	assymetric crown		Protect

Portland Tree Consulting Fieldwork done by Peter Torres, PN-0650B, on 1/13/2022 and 1/14/2022

Tag	Species	DBH	Dripline	Rating	Health & Structure	RPZ	Action
31289	Douglas-fir	16"	12	2	on a berm with shallow roots; assymetric crown		Remove
31290	blue spruce	10"	6	2	viable		Remove
31291	apple	14"	8	2	viable		Remove
31292	apple	6"	8	2	viable		Remove
31293	apple	8"	8	2	viable		Remove
31294	apple	8"	8	2	viable		Remove
31297	blue spruce	10"	8	2	viable		Remove
31298	apple	2X5"-8"	8	2	viable		Remove
31299	limber pine	9"	10	2	viable		Remove
31300	Sato Cherry	16"	12	2	viable		Remove
31301	Sato Cherry	8"	8	2	viable		Remove
31302	Sato Cherry	2X8"	10	2	viable		Remove
31303	ginkgo	6"	8	2	viable		Remove
31304	incense-cedar	20"	12	2	viable		Remove
31305	Norway maple	10"	8	2	ornamental variety		Remove
31306	Norway maple	12"	8	2	ornamental variety		Remove
31309	Norway maple	8"	8	2	ornamental variety		Remove
31310	paperbark maple	2X8"-9"	10	2	viable		Remove
31311	Deodar cedar	28"	16	2	viable		Remove
31312	Japanese maple	6X4"-7"	12	2	viable		Remove
31313	black oak	24"	24	2	viable		Remove
31314	black oak	18"	24	2	viable		Remove
31315	black oak	2X16"-18"	24	2	structural defect at grade		Remove
31316	red spruce	9"	8	2	on berm at SW Frog Pond Lane; shallow roots, assymetric crown		Remove

Portland Tree Consulting Fieldwork done by Peter Torres, PN-0650B, on 1/13/2022 and 1/14/2022

Species

- apple- *Maus sylvestris*
- bigleaf maple- *Acer macrophyllum*
- black oak- *Quercus velutina*
- Norway maple- *Acer platanoides*
- blue spruce- *Picea pungens*
- Cottonwood- *Populus tricharpa*
- Deodar cedar- *Cedrus deodara*
- Douglas fir- *Pseudotsuga menziesii*
- European birch- *Betula pendula*
- Gary oak- *Quercus garryana*
- giant sequoia- *Sequoia giganteum*
- ginkgo- *Ginkgo biloba*
- grand fir- *Abies grandis*
- incense-cedar- *Calocedrus decurrens*
- Japanese maple- *Acer japonica*
- limber pine- *Pinus flexilis*
- Lombardy poplar- *Populus nigra*
- Norway maple- *Acer platanoides*
- paperbark maple- *Acer griseum*
- Ponderosa pine- *Pinus ponderosa* var. *scopolorum*
- Portuguese laurel- *Prunus lusitana*
- red alder- *Alnus rubra*
- red spruce- *Picea rubens*
- Sato Cherry- *Prunus* sp.
- Scouler willow- *Salix scouleriana*
- sitka spruce- *Picea sitchensis*
- sweet cherry- *Prunus avium*
- western redcedar- *Thuja plicata*

Portland Tree Consulting Fieldwork done by Peter Torres, PN-0650B, on 1/13/2022 and 1/14/2022

Plotted: Apr. 18, 2023, - 10:14am. Mike Havens. L:\Projects\21200\21249\04_CADD\CAD\Draw\Middle Housing\21249_100.dwg. Layout Name: L1.10



WEST HILLS
LAND DEVELOPMENT
CONSULTANT

FROG POND OVERLOOK
24 DETACHED SINGLE FAMILY LOTS
CITY OF WILSONVILLE, OREGON
MIDDLE HOUSING
LANDSCAPE PLAN

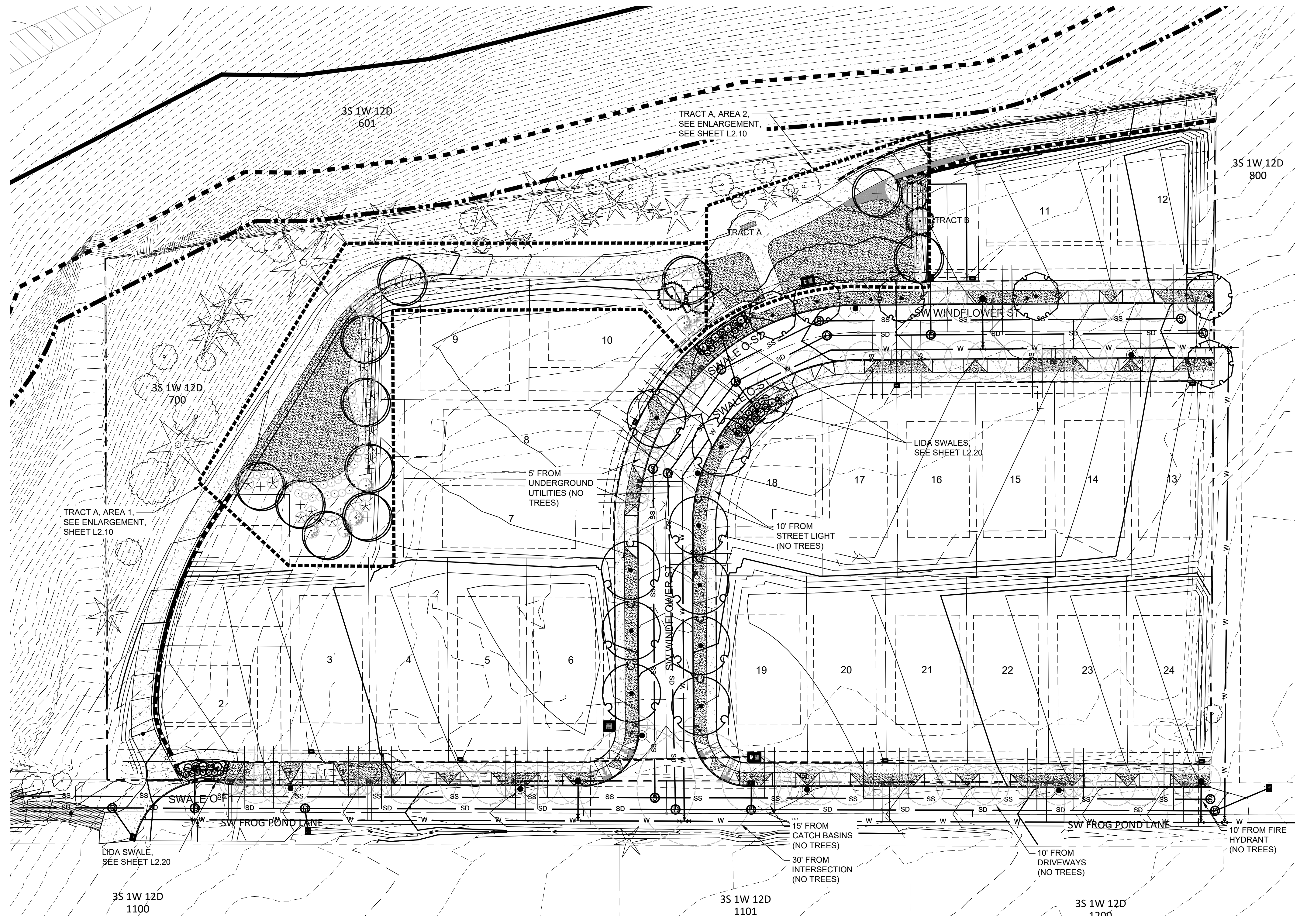

STREET TREE PLAN
SCALE: 1" = 50'-0"

PLANT SCHEDULE STREET PLANTING *CLASSIFIED AS A MODERATE WATER USAGE AREA (+/- ONE (1) INCH PER WEEK).

TREES	QTY	BOTANICAL / COMMON NAME	CONT	CAL	REMARKS	
	6	PISTACIA CHINENSIS / CHINESE PISTACHE	B&B	2"		
	9	QUERCUS RUBRA / RED OAK	B&B	2"	PRIMARY STREET	
GROUND COVERS	QTY	BOTANICAL / COMMON NAME	CONT	FIELD2	SPACING	REMARKS
	5,458 SF	TURF SEED DIAMOND GREEN - SUNMARK SEEDS / EXTREME LOW MAINTENANCE TURF	SEED			

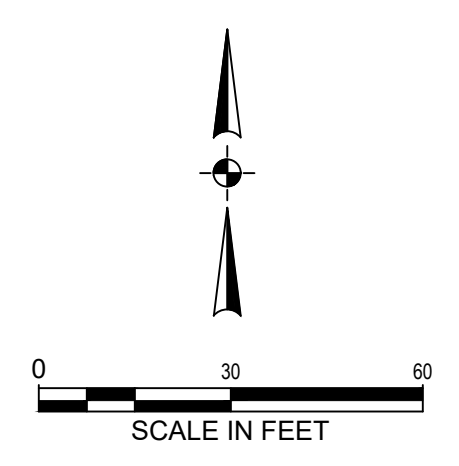

Plotted: Apr 26, 2023, 12:55pm, Elizabeth Oberlev, L:\Projects\212001248\04_CAD\CAD\Drawings\Middle_Housing\210151_200.dwg, Layout Name: L2.00

#	DATE	DESCRIPTION

REVISIONS

NAVD88 DATUM	
OTAK CAD DRAWN BY	KJB CHECKED BY
LAND USE STATUS	
TBD DATE	
21249 PROJECT NUMBER	

L2.00
© 2023 OTAK, INC.
If this drawing is not 22" x 34", it has been reduced/enlarged. Scale accordingly.

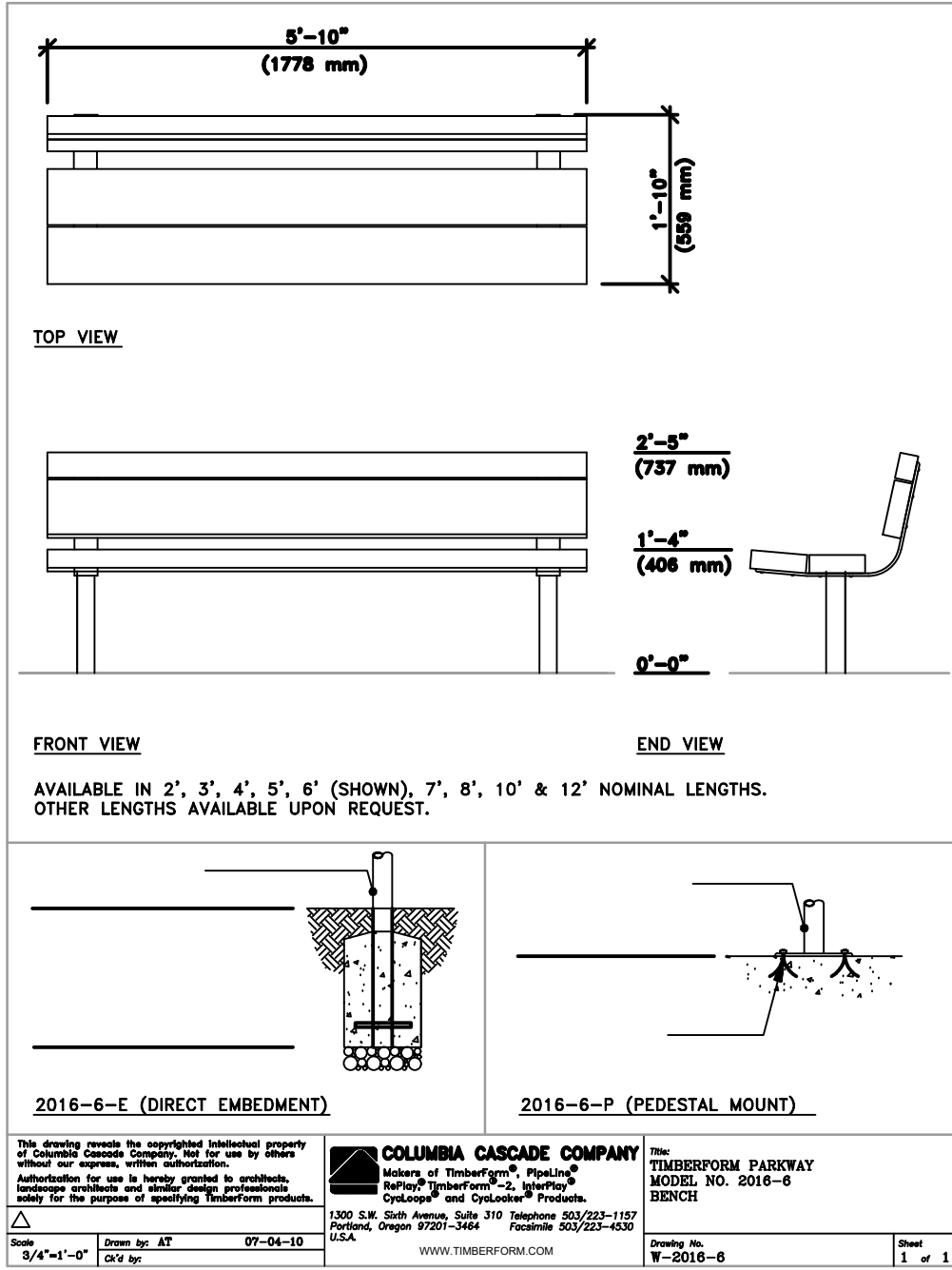

BENCH
SCALE: NTS

TRACT A LANDSCAPE PLAN AREA 1
SCALE: 1" = 10'-0"

TRACT A LANDSCAPE PLAN AREA 2
SCALE: 1" = 10'-0"

PLANT SCHEDULE TRACT A *CLASSIFIED AS A MODERATE WATER USAGE AREA (+/- ONE (1) INCH PER WEEK).

TREES	QTY	BOTANICAL / COMMON NAME	CONT	CAL	GROUND COVERS	QTY	BOTANICAL / COMMON NAME	CONT
	11	ACER RUBRUM 'BOWHALL' / BOWHALL MAPLE	B&B	2" CAL		184	ARCTOSTAPHYLOS UVA-URSI / KINNIKINNICK	4" POT
	4	PICEA PUNGENS / COLORADO SPRUCE	B&B	6'-8' HT.		59	LIRIOPE SPICATA 'SILVER DRAGON' / CREEPING LILY TURF	4" POT
SHRUBS	QTY	BOTANICAL / COMMON NAME	CONT					
	31	CEANOTHUS VELUTINUS / SNOWBRUSH	3 GAL			6,016 SF	TURF SEED DIAMOND GREEN - SUNMARK SEEDS / EXTREME LOW MAINTENANCE TURF	SEED
	39	MAHONIA AQUIFOLIUM / OREGON GRAPE	3 GAL					
	10	RHODODENDRON MACROPHYLLUM / PACIFIC RHODODENDRON	5 GAL					
	43	VACCINIUM OVATUM / EVERGREEN HUCKLEBERRY	3 GAL					

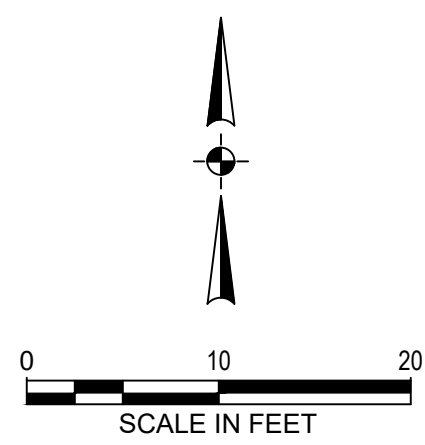

Otak
 Otak, Inc.
 808 SW Third Avenue, Ste. 800
 Portland, OR 97204
 503.287.6825
 www.otak.com

REGISTERED
 872
 PRELIMINARY
 GABRIEL A. KRUSE
 09/29/2015
 OREGON
 LANDSCAPE ARCHITECT
 EXPIRES: 9/30/2023

STAMP

WEST HILLS
 LAND DEVELOPMENT
 CONSULTANT

FROG POND OVERLOOK
 24 DETACHED SINGLE FAMILY LOTS
 CITY OF WILSONVILLE, OREGON
MIDDLE HOUSING
 TRACT LANDSCAPE PLAN

TITLE	#	DATE	DESCRIPTION

REVISIONS

NAVDB8
 DATUM

OTAK CAD KJB
 DRAWN BY CHECKED BY

LAND USE STATUS

TBD
 DATE
 21249
 PROJECT NUMBER

L2.10
 © 2023 OTAK, INC.
 If this drawing is not 22" x 34", it has been reduced/enlarged. Scale accordingly.

Plotted: Apr 18, 2023, 10:15am, Mike Hannes, L:\Projects\21200\21249\04_CADD\ACAD\Draw\Middle Housing\2001511200.dwg, Layout Name: L2.10

SEE AREA 2 BELOW

SEE AREA 1 ABOVE

This Detail Drawing may not be altered or changed in any manner except by the City Engineer. It is the responsibility of the user to acquire the most current version.

DO NOT HEAVILY PRUNE THE TREE AT PLANTING. PRUNE ONLY CROSSOVER LIMES, CO-DOMINANT LEADERS, AND BROKEN OR DEAD BRANCHES. SOME INTERIOR TWIGS AND LATERAL BRANCHES MAY BE PRUNED; HOWEVER, DO NOT REMOVE THE TERMINAL BUDS OF BRANCHES THAT EXTEND TO THE EDGE OF THE CROWN.

SEE TREE STAKING DETAIL FOR STAKING INSTRUCTIONS.

MARK THE NORTH SIDE OF THE TREE IN THE NURSERY, AND ROTATE TREE TO FACE NORTH AT THE SITE WHEN EVER POSSIBLE.

SET TOP OF ROOT BALL FLUSH TO GRADE OR 25-50 MM (1-2 IN.) HIGHER IN SLOWLY DRAINING SOILS.

50 MM (2 IN.) MULCH. DO NOT PLACE MULCH IN CONTACT WITH TREE TRUNK. MAINTAIN THE MULCH WEED-FREE FOR A MINIMUM OF THREE YEARS AFTER PLANTING.

NOTE: FOR DIMENSIONS OF PLANTING AREAS, TYPES OF SOIL AMENDMENTS, OR SOIL REPLACEMENT, SEE "SOIL IMPROVEMENT DETAILS."

NOTE: WIDTH OF PLANTING HOLE IS 3 TIMES ROOT BALL DIAMETER IN HIGHLY COMPACTED SOIL; 2 TIMES THE ROOT BALL DIAMETER MINIMUM IN ALL OTHERS. THIS DETAIL ASSUMES THE PLANTING SPACE IS LARGER THAN 2400 MM (8 FT.) SQUARE, OPEN TO THE SKY, AND NOT COVERED BY ANY PAVING OR GRATING.

Tree Planting Detail - B & B Trees in all Soil Types			CITY OF WILSONVILLE PUBLIC WORKS STANDARDS
DRAWING NUMBER: P-5000	DRAWN BY: SJ	SCALE: N.T.S.	
FILE NAME: P-5000.dwg	APPROVED BY: SA	DATE: 3/22/06	

This Detail Drawing may not be altered or changed in any manner except by the City Engineer. It is the responsibility of the user to acquire the most current version.

WIRE OR CABLE SIZES SHALL BE AS FOLLOWS:
TREES UP TO 65 MM (2.5 IN.) CALIPER - 14 GAUGE
TREES 65 MM (2.5 IN.) TO 75 MM (3 IN.) CALIPER - 12 GAUGE
TIGHTEN WIRE OR CABLE ONLY ENOUGH TO KEEP FROM SLIPPING. ALLOW FOR SOME TRUNK MOVEMENT. PLASTIC OR RUBBER HOSE SHALL BE LONG ENOUGH TO ACCOMMODATE 35MM (1.5 IN.) OF GROWTH AND BUFFER ALL BRANCHES FROM THE WIRE.
TUCK ANY LOOSE ENDS OF THE WIRE OR CABLE INTO THE WIRE WRAP SO THAT NO SHARP WIRE ENDS ARE EXPOSED.

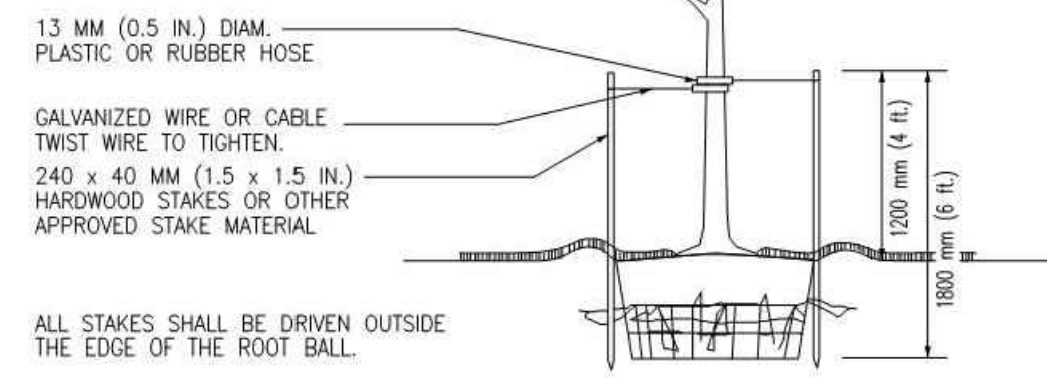

ASSURE THAT THE BEARING SURFACE OF THE PROTECTIVE COVERING OF THE WIRE OR CABLE AGAINST THE TREE TRUNK IS A MINIMUM OF 12 MM (0.5 IN.).
REMOVE ALL STAKING AS SOON AS THE TREE HAS GROWN SUFFICIENT ROOTS TO OVERCOME THE PROBLEM THAT REQUIRED THE TREE TO BE STAKED. STAKES SHALL BE REMOVED NO LATER THE END OF THE FIRST GROWING SEASON AFTER PLANTING.
TREES NORMALLY DO NOT NEED TO BE STAKED AND STAKING CAN BE HARMFUL TO THE TREE. STAKING SHOULD BE DONE ONLY WITH THE APPROVAL OF THE CITY IF IT IS EXPECTED THAT THE TREE WILL NOT BE ABLE TO SUPPORT ITSELF. THE FOLLOWING ARE REASONS WHY TREES DO NOT REMAIN STRAIGHT:
o TREES WITH POOR - QUALITY ROOT BALLS OR ROOT BALLS THAT HAVE BEEN CRACKED OR DAMAGED. REJECT RATHER THAN STAKE.
o TREES THAT HAVE GROWN TOO CLOSE TOGETHER IN THE NURSERY, RESULTING IN WEAK TRUNKS. REJECT RATHER THAN STAKE.
o PLANTING PROCEDURES THAT DO NOT ADEQUATELY TAMP SOILS AROUND THE ROOT BALL. CORRECT THE PLANTING PROCEDURE.
o ROOT BALLS PLACED ON SOFT SOIL. TAMP SOILS UNDER ROOT BALL PRIOR TO PLANTING.
o ROOT BALLS WITH VERY SANDY SOIL OR VERY WET CLAY SOIL. STAKING ADVISABLE.
o TREES LOCATED IN A PLACE OF EXTREMELY WINDY CONDITIONS. STAKING ADVISABLE.
ALTERNATE TREE STAKING METHODS:
1. TREE STAPLES OR EQUIVALENT TREE STAKING SYSTEM MAY BE USED
2. DUCKBILL ROOT KIT STRAP OR EQUIVALENT
- 40Rbk - 2" TREE
- 68Rbk - 3" TREE

Tree Staking Detail - Trees 75MM (3") Caliper or Less			CITY OF WILSONVILLE PUBLIC WORKS STANDARDS
DRAWING NUMBER: P-5005	DRAWN BY: SJ	SCALE: N.T.S.	
FILE NAME: P-5005.dwg	APPROVED BY: SA	DATE: 03/22/06	

This Detail Drawing may not be altered or changed in any manner except by the City Engineer. It is the responsibility of the user to acquire the most current version.

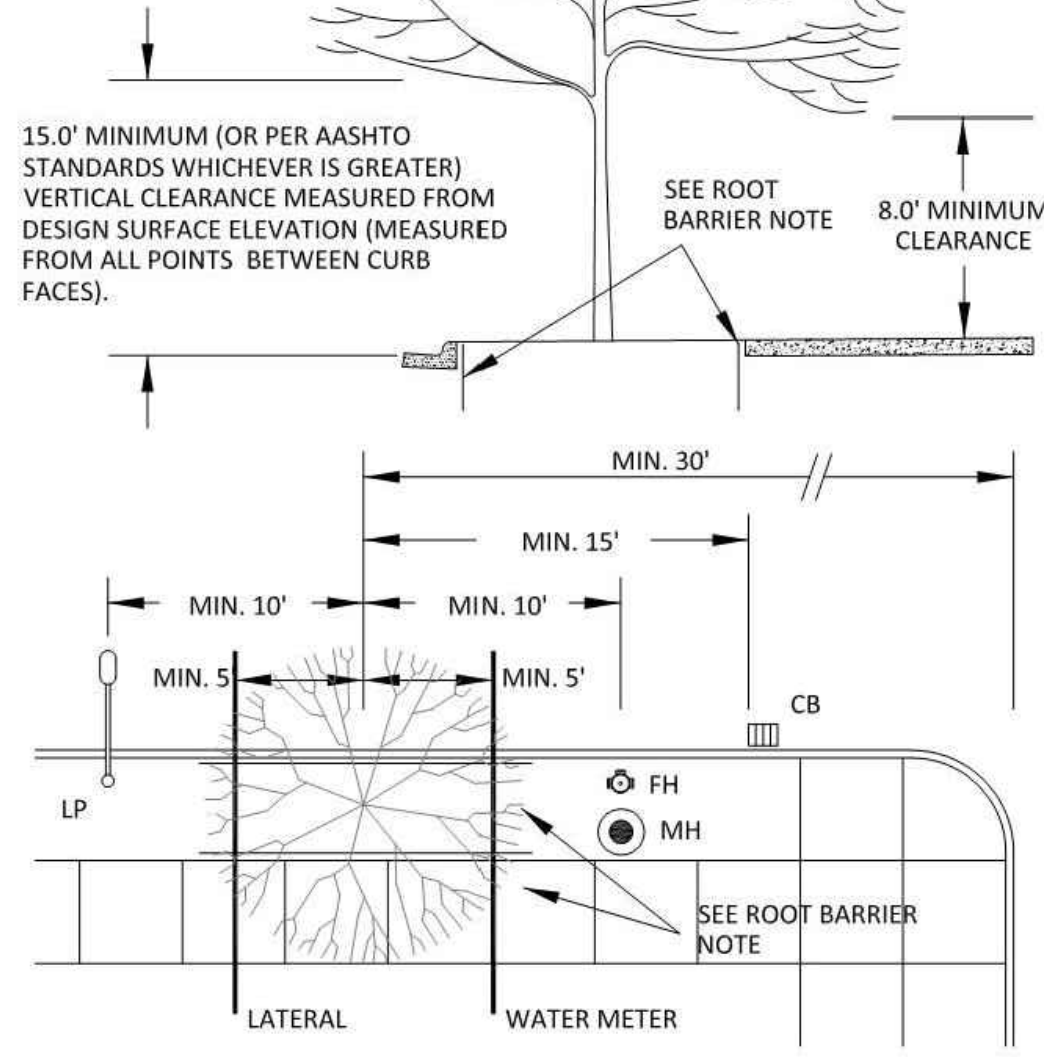

- NOTES:
- 5' MINIMUM CLEARANCE FROM UNDERGROUND UTILITIES AND LATERALS. LANDSCAPE DESIGN OF TREES AND ENGINEERING DESIGN OF UNDERGROUND SERVICES SHALL BE COORDINATED.
 - TREES SHALL BE CENTERED BETWEEN CURB AND SIDEWALK.
 - CITY APPROVED ROOT BARRIER METHOD TO BE USED FOR ALL STREET TREES LOCATED WITHIN 8 FEET OF ALL CURBS AND SIDEWALKS. ROOT BARRIER SHALL EXTEND TO A DISTANCE OF 20' CENTERED WITH THE TREE BASE. BARRIER SHALL BE 2'-4" FROM CURB OR SIDEWALK AND EXTEND A MINIMUM OF 24" IN DEPTH.
 - WHEN TREES ARE WITHIN TREE WELLS, ROOT BARRIER SHALL BE PLACED ON ALL SIDES.
 - PARALLEL PARKING: LOCATE TREE BETWEEN ON-STREET PARKING SPACES. THIS LOCATION PRECLUDES DOORS OPENING ONTO TREES AND PASSENGERS EXITING IN CONFLICT WITH TREE PLACEMENT.
 - DIAGONAL PARKING: LOCATE TREE MINIMUM 3' AWAY FROM LEFT STALL LINE TOWARD THE CENTER OF THE PARKING SPACE. THIS LOCATION ATTEMPTS TO AVOID THE FRONT END OF THE PARKED CAR OVERHANGING THE CURB.

Street Tree Location and Clearances			CITY OF WILSONVILLE PUBLIC WORKS STANDARDS
DRAWING NUMBER: RD-1240	DRAWN BY: SR	SCALE: N.T.S.	
FILE NAME: RD-1240.DWG	APPROVED BY: NK	DATE: 12/31/14	

CONTRACTOR IS CAUTIONED THAT EXISTING UNDERGROUND FACILITIES OCCUR THROUGHOUT THE WORK AREAS INCLUDING BUT NOT LIMITED TO POWER, GAS, TELEPHONE, WATER SUPPLY, AND IRRIGATION. CONTRACTOR SHALL MARK THE FACILITIES BEFORE WORK, POTHOLE WHERE NECESSARY, AND PROTECT DURING CONSTRUCTION. IMMEDIATELY NOTIFY OWNER'S REPRESENTATIVE IF ANY CONFLICTS ARE FOUND.

- GENERAL: SEVERAL OF THE FOLLOWING NOTES SUMMARIZE THE PROJECT SPECIFICATIONS FOR THE CONTRACTORS CONVENIENCE. IF A DISCREPANCY EXISTS BETWEEN THESE NOTES AND THE PROJECT SPECIFICATIONS THE SPECIFICATIONS SHALL OVERRIDE.
- THE LANDSCAPE CONTRACTOR IS TO THOROUGHLY REVIEW THE SITE. IF THERE ARE ANY DISCREPANCIES BETWEEN THE PLAN AND THE EXISTING CONDITIONS THE OWNERS REPRESENTATIVE IS TO BE NOTIFIED IMMEDIATELY.
- IF THE LANDSCAPE CONTRACTOR STARTS WORK BEFORE SITE CONDITIONS ARE READY OR CONTINUES WORK IN ADVERSE CONDITIONS WITHOUT PRIOR APPROVAL THEY WILL BE RESPONSIBLE FOR ANY ADDITIONAL COSTS RELATING TO THE CONDITION.
- IMMEDIATELY NOTIFY OWNERS REPRESENTATIVE CONCERNING ANY CONDITION AT ANY TIME DURING CONSTRUCTION THAT IS DETRIMENTAL TO THE HEALTH AND VIGOROUS GROWTH OF THE SPECIFIED PLANT MATERIAL.
- PROVIDE QUANTITY OF PLANT MATERIAL INDICATED IN PLANT LIST OR THE QUANTITY REQUIRED TO COVER AREAS INDICATED AT SPECIFIED SPACING, WHICHEVER IS GREATER.
- IF AN AREA DIFFERS SIGNIFICANTLY IN SIZE FROM THAT SCALED ON DRAWING AND REQUIRES MORE OR LESS MATERIAL THE OWNERS REPRESENTATIVE IS TO BE INFORMED.
- TOPSOIL: APPLY 9-INCH IMPORT TOPSOIL TO NEW PLANTED EXCEPT:
 - AT STORM POND AND LIDA FACILITIES INSTALL STORMWATER FACILITY GROWING MEDIUM PER CITY OF WILSONVILLE 2015 STORMWATER & SURFACE WATER DESIGN & CONSTRUCTION STANDARDS SECTION 3.A.4.00.
 - DO NOT APPLY TOPSOIL TO RIPARIAN MITIGATION AREA IN SROZ.
- SOIL ANALYSIS: CONTRACTOR SHALL OBTAIN A COPY OF OWNER-PROVIDED SOIL TEST. AMEND AND FERTILIZE IN CONFORMANCE WITH RECOMMENDATIONS INDICATED IN THE REPORT.
- COMPOST: APPLY 3-INCH DEPTH COMPOST TO TOPSOIL. DO NOT APPLY AT STORM OR LIDA FACILITIES. THOROUGHLY BLEND WITH TOPSOIL TO A DEPTH OF 6 INCHES.
 - DO NOT APPLY COMPOST TO RIPARIAN MITIGATION AREA IN SROZ.
- FERTILIZER: APPLY FERTILIZER TO ALL PLANT HOLES AND TURF AREAS OF THE TYPE, QUANTITY, APPLICATION METHOD, AND TIMING NOTED IN THE SPECIFICATIONS. DO NOT APPLY FERTILIZER AT STORM FACILITIES.
- BARK MULCH: SPREAD 3-INCH DEPTH FINE-MEDIUM GRADE FIR/HEMLOCK BARK OVER SHRUB BEDS. DO NOT APPLY MULCH AT STORM POND, LIDA FACILITIES, OR IN RIPARIAN MITIGATION AREA IN SROZ. KEEP BARK CLEAR OF TREE AND SHRUB STEM BASE.
- PLANTING POCKETS: BACK FILL PLANT HOLE WITH SOIL EXCAVATED FROM HOLE. DO NOT ADD ADDITIONAL AMENDMENTS.
- ROOT BARRIER: INSTALL PER CITY OF WILSONVILLE DETAIL RD-1240. SEE SHEET L3.0.
- PLANT MATERIAL: ALL PLANT MATERIAL SHALL MEET MINIMUM QUALITY AND SIZE REQUIREMENTS ESTABLISHED IN THE AMERICAN STANDARD FOR NURSERY STOCK GUIDELINES.
- LEAVE PLANT NAME IDENTIFICATION TAGS ON TEN PERCENT OF ALL TREES AND SHRUBS INSTALLED TO AID INSPECTORS IN VERIFYING THAT SPECIFIED PLANTS HAVE BEEN INSTALLED.
- PLANT CENTER OF SHRUBS A MINIMUM OF 24 INCHES FROM ADJACENT PAVING. PLANT GROUNDCOVERS A MINIMUM OF 18 INCHES FROM ADJACENT PAVING. WHERE PLANTER IS LESS THAN 6 FEET WIDE, SET PLANTS HALF OF THE NOTED PLANT SPACING FROM ADJACENT PAVING.
- WHERE PLANT BED SLOPE IS LESS THAN 3% MOUND PLANTING BED AREAS 3% MINIMUM FOR POSITIVE DRAINAGE.
- SEE SPECIFICATIONS FOR FINAL INSPECTION, MAINTENANCE, AND WARRANTY REQUIREMENTS UNIQUE TO THIS PROJECT.
- SEE SPECIFICATIONS FOR OTHER LANDSCAPE CONSTRUCTION REQUIREMENTS.

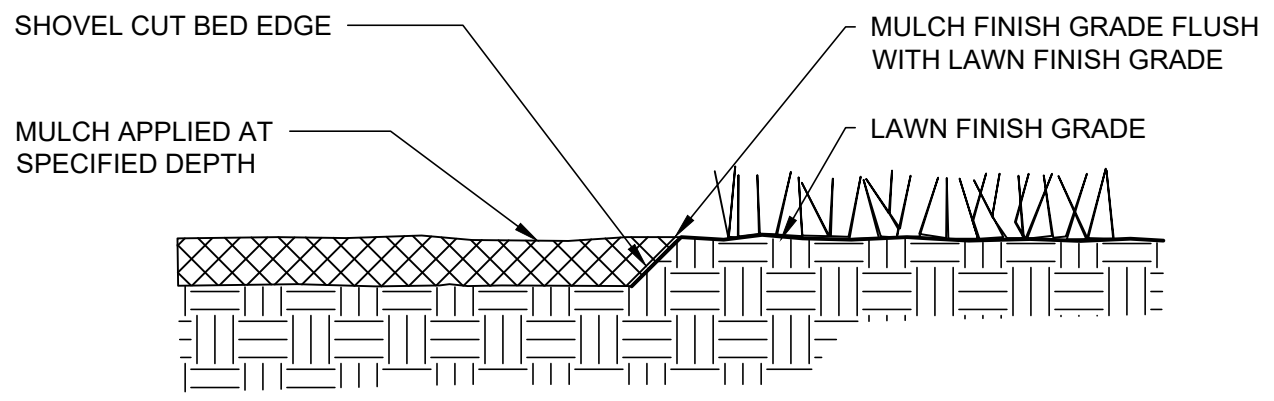

SHOVEL CUT BED EDGE

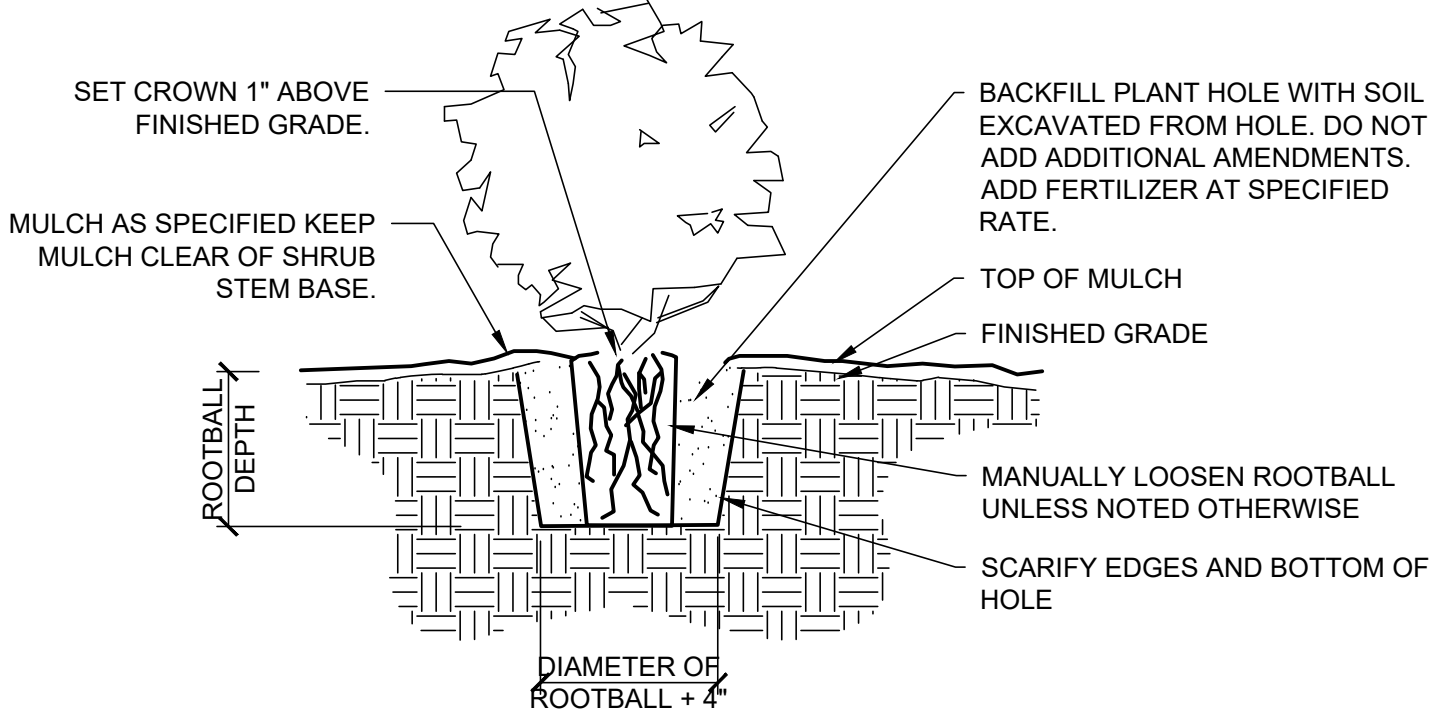

SHRUB PLANTING DETAIL

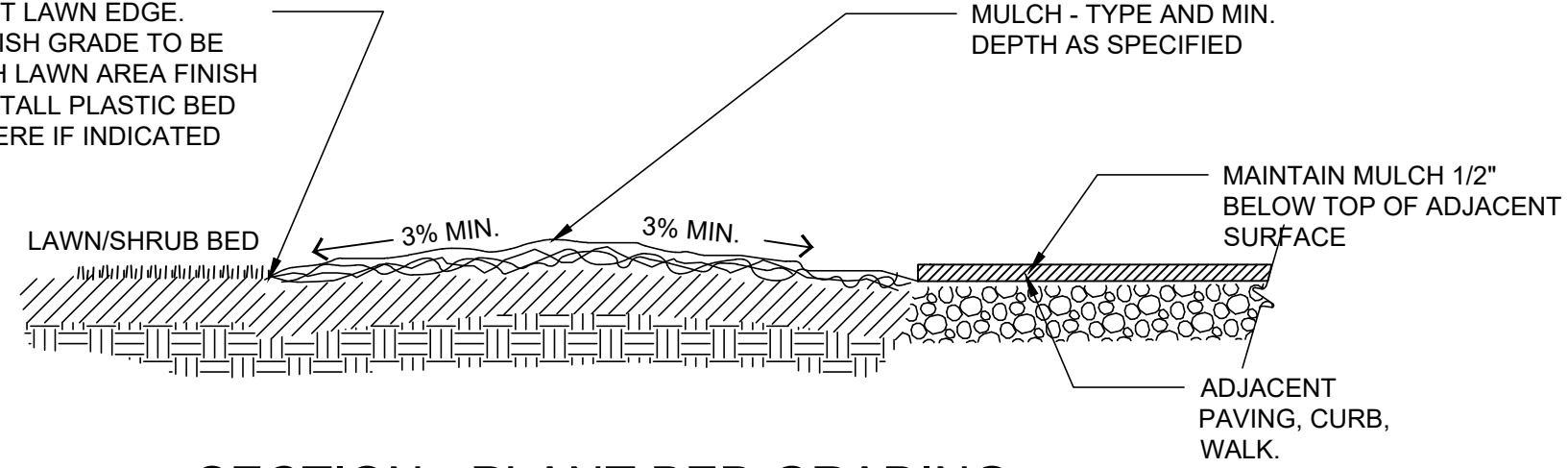

SECTION - PLANT BED GRADING



Otak, Inc.
808 SW Third Avenue, Ste. 800
Portland, OR 97204
503.287.6825
www.otak.com



FROG POND OVERLOOK
 24 DETACHED SINGLE FAMILY LOTS
 CITY OF WILSONVILLE, OREGON
MIDDLE HOUSING

LANDSCAPE NOTES AND DETAILS

TITLE		
#	DATE	DESCRIPTION

REVISIONS	
NAV/D88	DATUM
OTAK CAD	KJB
DRAWN BY	CHECKED BY
LAND USE	STATUS
TBD	DATE
21249	PROJECT NUMBER

L3.00
© 2023 OTAK, INC.
If this drawing is not 22" x 34", it has been reduced/enlarged. Scale accordingly.

Plotted: Apr 18, 2023 - 10:15am, Mike Havens, L:\Projects\21200\21249\04_CADD\ACAD\Drawn\Middle Housing\200151\200.dwg, Layout Name: L3.00



Frog Pond Terrace, Frog Pond Overlook
Preliminary Storm Drainage Report
Land Use

Submitted to:

City of Wilsonville
29799 SW Town Center Loop E.
Wilsonville, OR 97070

March 2023

Prepared by:

Otak, Inc.
808 SW Third Avenue, Suite 800
Portland, OR 97204

Project No. 21249

Acknowledgements

Project Name: Frog Pond Terrace, Frog Pond Overlook
Type of Report: Preliminary
Submittal Level: Land Use

Site Information

Subject Property: 31W12D Tax lots 700, 2800, 2801
Applicant Information: Dan Grimberg
West Hills Land Development
3330 NW Yeon St. Suite 200
Portland, OR 97210
503-789-0358

Project Development Team

Stormwater Lead: Rose Horton, PE
Stormwater Designer: Roger Tiffany, EIT

TABLE OF CONTENTS

	Page
Section 1. Introduction	1
Section 2. Project Description	1
Permitting	2
Existing Conditions	2
Proposed Conditions	2
Section 3. Hydrology	2
Rainfall Depth	2
Pollutants of Concern	2
Wetlands	3
Soils	3
Flood Hazard	3
Section 4. Methodology	3
BMP Sizing Tool Hydrology	4
Drainage	4
Conveyance	4
Section 5. Water Quality Treatment	5
Low Impact Development	5
Water Quality Facilities	5
Section 6. Flow Control	5
Section 7. Operations and Maintenance	6
Section 8. Conclusion	6
Section 9. References	6

TABLES

Table 1	24 Hour Precipitation Depths	2
Table 2	Pollutants of Concern	2
Table 3	Facility Summary Table	6
Table 4	Detention Pond Summary Table	6

FIGURES

Figure 1	Existing Conditions
Figure 2	Frog Pond Terrace – Proposed Conditions
Figure 3	Frog Pond Overlook – Proposed Conditions

APPENDICES

Appendix A	Hydrology
Appendix B	Geotechnical Report
Appendix C	Downstream Analysis
Appendix D	BMP Sizing Tool Output
Appendix E	Operations and Maintenance Plans

Section 1. Introduction

The Frog Pond Terrace and Frog Pond Overlook sites are proposed residential developments located within the West Neighborhood of the Frog Pond Area Plan. The combined 8.81 acres of property and right-of-way are comprised of Tax map 31W12D lots 700 (Terrace), 2800 and 2801 (Overlook) in Clackamas County within the City of Wilsonville Urban Growth Boundary (UGB) (see Vicinity Map). The Frog Pond Terrace and Frog Pond Overlook developments will consist of 19 and 21 single-family residential dwellings respectively as well as associated public infrastructure improvements including SW Frog Pond Lane, resulting in 5.00 acres in new or replaced impervious surface area.

The purpose of this document is to demonstrate compliance of the Frog Pond Terrace and Frog Pond Overlook stormwater management system with the City of Wilsonville Stormwater and Surface Water Design and Construction Standards (2015). Descriptions of the existing and proposed hydrologic conditions, as well as documentation showing compliance of the proposed onsite stormwater management system with City of Wilsonville standards for water quality and quantity are included in this report.



Vicinity Map

Section 2. Project Description

The Frog Pond Terrace and Frog Pond Overlook proposed residential developments consist of 40 new single-family lots, local street extensions, as well as sidewalks, public roadway improvements, utilities, and stormwater management systems that discharge to Boeckman Creek. Additionally, this project will include frontage improvements to SW Frog Pond Lane.

Permitting

The following permit applications will be required for this project:

- City of Wilsonville Development Permit
- Section 401 water quality certification from DEQ

Existing Conditions

The project site, shown in Figure 1, is primarily agricultural with a home and outbuildings that comprise 0.66 acres of impervious area. The Frog Pond Terrace project site slopes west at about 5% while the Frog Pond Overlook project site slopes north at about 4%. The right-of-way (ROW) of SW Frog Pond Lane that fronts on the Frog Pond Overlook site includes 0.02 acres of impervious pavement. Both project sites slope towards Boeckman Creek. This proposed project will maintain drainage patterns.

Proposed Conditions

Site improvements will include construction of approximately 5.00 acres of new or replaced impervious surfaces in the form of roof, roadway, and sidewalk area. A detention pond and vegetated stormwater swales are proposed to be constructed within the right-of-way and tracts to provide low impact development water quality treatment and flow control throughout the proposed residential developments. Runoff from approximately 14.5 acres of undeveloped offsite area will be conveyed through the site's stormwater infrastructure.

Section 3. Hydrology

Rainfall Depth

The following rainfall depths listed in Table 1 are provided in the City of Wilsonville Public Works Standards (2015). These depths correspond to design recurrence intervals which are used in hydrologic calculations for various aspects of stormwater management design.

Table 1 24 Hour Precipitation Depths

Recurrence Interval (Years)	Total Precipitation Depth (inches)
2	2.50
10	3.45
25	3.90
100	4.50

Pollutants of Concern

The pollutants of concern are those typically found in roadway runoff. These include sediment, oil and grease, polycyclic aromatic hydrocarbons (PAHs), metals such as Copper, Zinc, and Lead as well as pesticides and other nutrients (DEQ, 2016). Table 2 lists each waterway affected by this project and DEQ listing status.

Table 2 Pollutants of Concern

Waterway	Parameter	Listing Status
Boeckman Creek	N/A	None
Willamette River (Middle)	Chlorophyll a	303(d), TMDL needed

Waterway	Parameter	Listing Status
Willamette River (Middle)	E. Coli	TMDL approved
Willamette River (Middle)	Mercury	303(d), TMDL needed
Willamette River (Middle)	Temperature	TMDL approved

Wetlands

Wetland and water boundaries were delineated by AKS Engineering and Forestry on December 2, 2021. Wetlands were delineated adjacent to Boeckman Creek. The project is not anticipated to impact wetlands or waters. The project will impact the Significant Resource Overlay Zone (SROZ). Discussion of the impacts to sensitive areas will be provided by the environmental consultant, AKS.

Soils

The Web Soil Survey published by the United States Department of Agriculture (USDA) Natural Resources Conservation Service (NRCS) was referenced to determine the soil names, symbols, and hydrologic soil groups found on the project site. The soil type identified within the project area is identified as Woodburn silt loam (91B/C). These soils are classified as hydrologic soil type C, which in an undrained condition generally exhibit slow infiltration rates when thoroughly wet. The USDA soil survey map and the corresponding hydrologic soil group (HSG) for the area of interest are provided in Appendix A.

A geotechnical investigation was conducted to determine the site strata and infiltration rates. The field exploration did not encounter the static groundwater table and well data indicates that the groundwater table is at least 20 feet below ground surface. Perched groundwater conditions may occur during the wet season. Infiltration testing at a depth of five to six feet below ground surface yielded infiltration rates between 0.6 to 1.2 inches/hour. The geotechnical engineer stated that the lower value is more representative of the site and that a safety factor of at least 2 be applied to the design infiltration rate. The onsite Geotechnical Memorandum by Hardman Geotechnical Services is included in Appendix B.

Flood Hazard

The proposed development for this site is located outside the 100-year floodplain boundary designated by the Federal Emergency Management Agency (FEMA) Flood Insurance Rate Map (FIRM) for Clackamas County, Oregon and Incorporated Areas, Panel 234, June 17, 2008. See Appendix A for the FIRMette of the proposed site.

Section 4. Methodology

The stormwater system for the proposed Frog Pond Terrace/Overlook development was modeled using the following methods and design standards:

- **Water Quality:** The City of Wilsonville requires capture and treatment of 80% of the average annual runoff (approximately 1-inch in 24 hours). The City of Wilsonville has adopted a BMP Sizing Tool that was developed to aid in the design of detention and water quality low impact development facilities. The City of Wilsonville BMP Sizing Tool was used to size the minimum facility footprint areas to meet the water quality treatment standard.
- **Flow Control:** The BMP sizing tool was also simultaneously used to calculate facility sizes to include flow control. This tool provides the necessary calculations to design a facility to meet the City's flow

duration matching standards whereby the “duration of peak flow rates from post development conditions shall be less than or equal to the duration of peak flow rates from pre-development conditions for all peak flows between 42% of the 2-year storm peak flow rate up to the 10-year peak flow rate.”

- **Conveyance:** The Santa Barbara Urban Hydrograph (SBUH) method will be used to calculate design conveyance flow rates and XP-SWMM software will be used to size the project conveyance system. The City’s design event for pipe conveyance is the 25-year, 24-hour storm, requiring 1-foot of freeboard between the hydraulic grade line and finished grade at structure rims.

BMP Sizing Tool Hydrology

The BMP Sizing Tool was created to aid in designing low impact development facilities for both treating stormwater runoff and matching flow durations between target conditions and developed conditions. City standards consider target conditions to be pre-development, prior to any human settlement. City of Wilsonville standards stipulate that the pre-developed vegetation of Oak Savannah, which applies to the project site, should be modeled in the sizing tool as grass. Proposed conditions were set to paved conditions for roof, roadway, and sidewalk, and set to landscaped conditions for landscaped and other disturbed pervious areas within the project boundary.

A detention pond and vegetated filtration swales will function to provide both water quality and flow control mitigation. The BMP Sizing Tool provides minimum facility footprint areas for treatment and flow control. The BMP Sizing Tool also provides the required orifice sizes for incorporating the flow control component into these facilities.

Drainage

The developed site drains to Boeckman Creek over a mile north of its discharge point at the Willamette River. The Boeckman Creek drainage basin upstream of the project site is approximately 800 acres and the project area comprises less than 2% of the contributing drainage basin. Boeckman Creek is confined to a deep channel approximately 40 feet below the adjacent developments. A flow control structure on the creek exists in Boeckman Creek directly upstream of SW Boeckman Road (Wilsonville, 1992). Otak conducted a downstream impact analysis on the downstream section of Boeckman Creek per City of Wilsonville standards and the downstream impact analysis is included in Appendix C.

Conveyance

The proposed development will include a piped conveyance network that will convey flows to Boeckman Creek. Pipes draining the project site will be designed to meet City of Wilsonville conveyance standards.

The Santa Barbara Urban Hydrograph (SBUH) method will be used to calculate runoff rates generated under proposed developed conditions for contributing onsite areas as well as offsite upstream areas. The City of Wilsonville Public Works Standards (2015) identifies the 25-year, 24-hour storm to be used for conveyance design, maintaining 1-foot of clearance between the hydraulic grade line and conveyance structure rim elevations. The City also requires an assessment of the 100-year storm event impacts to the proposed system. Flow rates during the 100-year may be conveyed overland but are not expected to inundate existing structures. The stormwater conveyance network will be sized during final design.

Section 5. Water Quality Treatment

Low Impact Development

The City of Wilsonville promotes the use of Low Impact Development (LID) approaches to meet water quality treatment standards. Locations of LID facilities for water quality treatment for the Frog Pond Terrace and Frog Pond Overlook project site are shown on Figures 2 and 3.

Water Quality Facilities

Water quality treatment will be provided through a detention pond and filtration vegetated swales. The BMP Sizing Tool was used to calculate minimum facility sizes to satisfy water quality requirements. Facility sizing calculation reports from the BMP Sizing Tool are provided in Appendix D.

The Frog Pond Terrace project includes right-of-way improvements that complete the northern side of SW Brisband Street. The southern side of the street was developed with the Morgan Farm Phase 2 project located south of Frog Pond Terrace. Frog Pond Terrace Basins T14 and MF will drain to an existing swale on the Morgan Farm project (see Figure 3). The Morgan Farm storm report (PDG, 2019) shows that Basin MF, which is located south of the property line, was included in the design of Morgan Farm Swale 1. The existing Swale 1 and contributing drainage areas were modeled in the BMP tool based on the WES BMP Sizing Report appendix of the Morgan Farm storm report and Basin T14 was added to confirm that the swale is adequately sized to manage runoff from both sides of the street.

The proposed ten-foot wide pedestrian trail along the west end of the site is located adjacent to a steep slope where it is not feasible to install stormwater management facilities. Runoff from the trail will sheet flow through a vegetated area toward Boeckman Creek. The trail is located 100 to 250 feet away from the creek.

Section 6. Flow Control

City of Wilsonville Public Works Standards (2015) requires the use of flow attenuation when a proposed development increases impervious surface area by more than 5,000 square feet. Therefore, this project site will require flow control mitigation prior to discharging site runoff to downstream conveyance systems (open or closed channels or conduits). Per City requirements, the “post-development conditions shall be less than or equal to the duration of peak flow rates from pre-development conditions for all peak flows between 42% of the 2-year storm peak flow rate up to the 10-year peak flow rate.”

Flow control structures will be located immediately downstream of the detention pond and vegetated filtration swales, per the City’s standard detail. These facilities provide flow control by installing orifices at the end of their corresponding underdrain pipes to backwater flows into the available storage and voids present in facility soil and rock layers. Water is released from the facility through the orifice, which is sized to meter flows at a rate that meets flow control standards. Certain swales are sized to only provide water quality treatment. All proposed swales flow to the pond which provides flow control and water quality treatment.

Orifices are provided for flow control purposes only; construction details of the flow control structures are provided on the plan sheets. A summary of facilities to serve this project is presented in Tables 3 and 4.

Table 3 Facility Summary Table

Basin ID	Facility ID	Function	LID Min. Size, BMP Output (sf)	LID Treatment Size, Site Plan (sf)	Orifice Diameter (in)
T11	Swale 1	WQ	150	294	0.6
T12	Swale 2	WQ, FC	157	336	0.6
T13	Swale 3	WQ, FC	274	336	0.8
O3	Swale 4	WQ	182	221	0.6
O4	Swale 5	WQ	184	208	0.6
FP2, FP3	Swale 6	WQ	89	183	0.4
T15	Swale 8	WQ	47	128	0.3
T3	Swale 9	WQ	82	124	0.4

Table 4 Detention Pond Summary Table

Basin ID	Facility ID	Function	Max Depth (ft)	Treatment Area (sf)
T1-T2, T4-T10, T16, O1, O2a/b, O5, FP1, FP4, FP5	Pond	WQ, FC	5.0	7,523

Section 7. Operations and Maintenance

Vegetated facilities will be maintained by the private development. Operations and Maintenance requirements are included in Appendix E in conjunction with corresponding standard details for each type of facility. The following representative will be responsible for ongoing maintenance of onsite facilities: Dan Grimberg, Director of Land Development at West Hills Development, 503-641-7342.

Section 8. Conclusion

The proposed Frog Pond Terrace and Frog Pond Overlook developments will include a stormwater management system designed to comply with standards set forth by the City of Wilsonville. The proposed development will create 5.00 acres of impervious area. Runoff from impervious areas will be treated by LID facilities, including a detention pond and vegetated filtration swales. Flow control requirements will also be met by adding orifices at the downstream end of underdrain to regulate outflows from the detention pond and vegetated swales. The BMP Sizing Tool was used to calculate minimum facility and orifice sizes to satisfy water quality and flow control requirements. In accordance with City of Wilsonville standards, the conveyance system will be sized to convey the 25-year, 24-hour storm event with a minimum of 1-foot of freeboard between the hydraulic grade line (HGL) and the finished grade elevation.

Section 9. References

AKS, 2021A. *Natural Resources Feasibility Map SW Frog Pond Lane Martin Properties*, AKS Engineering & Forestry, October 2021.

AKS, 2021B. *Natural Resources Feasibility Map SW Frog Pond Lane Ross Properties*, AKS Engineering & Forestry, October 2021.

AKS, 2021C. *Frog Pond Terrace Significant Resource Impact Report*, AKS Engineering & Forestry,

December 2021.

DEQ, 2016. *Section 401 Water Quality Certification*, State of Oregon Department of Environmental Quality, May 2016.

FEMA, 2017. *FEMA Map Service Center*. <<http://msc.fema.gov/>> Accessed: December 11, 2019.

Hardman, 2021. Geotechnical Engineering and Infiltration Testing Report – Frog Pond West-West – Martin, George and Ross Properties, Wilsonville, Oregon, Hardman Geotechnical Services Inc., December 15, 2021

National Resource Conservation Services, 2018. *United States Department of Agriculture. Web Soil Survey*. <<http://websoilsurvey.nrcs.usda.gov/>> Accessed: August 17, 2021.

PDG, 2019. *Final Storm Drainage Report: Morgan Farms – Phase 2*, Pioneer Design Group, January 2019.

SCS, 1986. *Technical Release 55: Urban Hydrology for Small Watersheds*, United States Department of Agriculture Soil Conservation Service, June 1986.

USACE, 2014. *Standard Local Operating Procedures for Endangered Species (SLOPES V) to Administer Maintenance or Improvement of Stormwater, Transportation or Utility Actions*, United States Army Corps of Engineers, March 14, 2014.

Wilsonville, 1992. *Boeckman Creek Detention. Job No. 92-06-001*, City of Wilsonville, June 1992.

Wilsonville, 2015. *City of Wilsonville Public Works Standards. Section 3, Stormwater & Surface Water Design and Construction Standards 2015*; Revised December 2015.

Figures

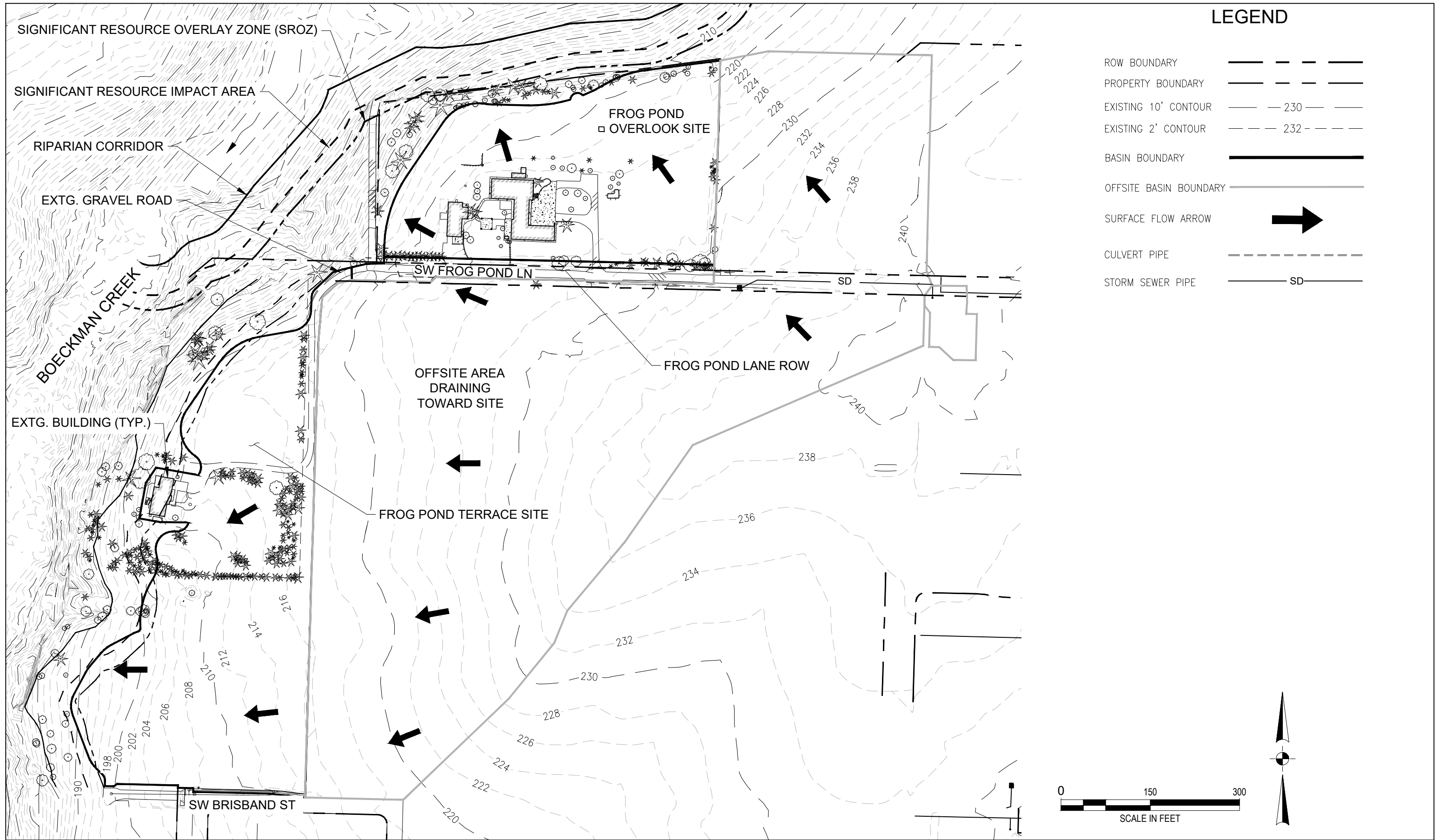

FROG POND TERRACE & OVERLOOK | PRELIMINARY DESIGN | EXISTING CONDITIONS



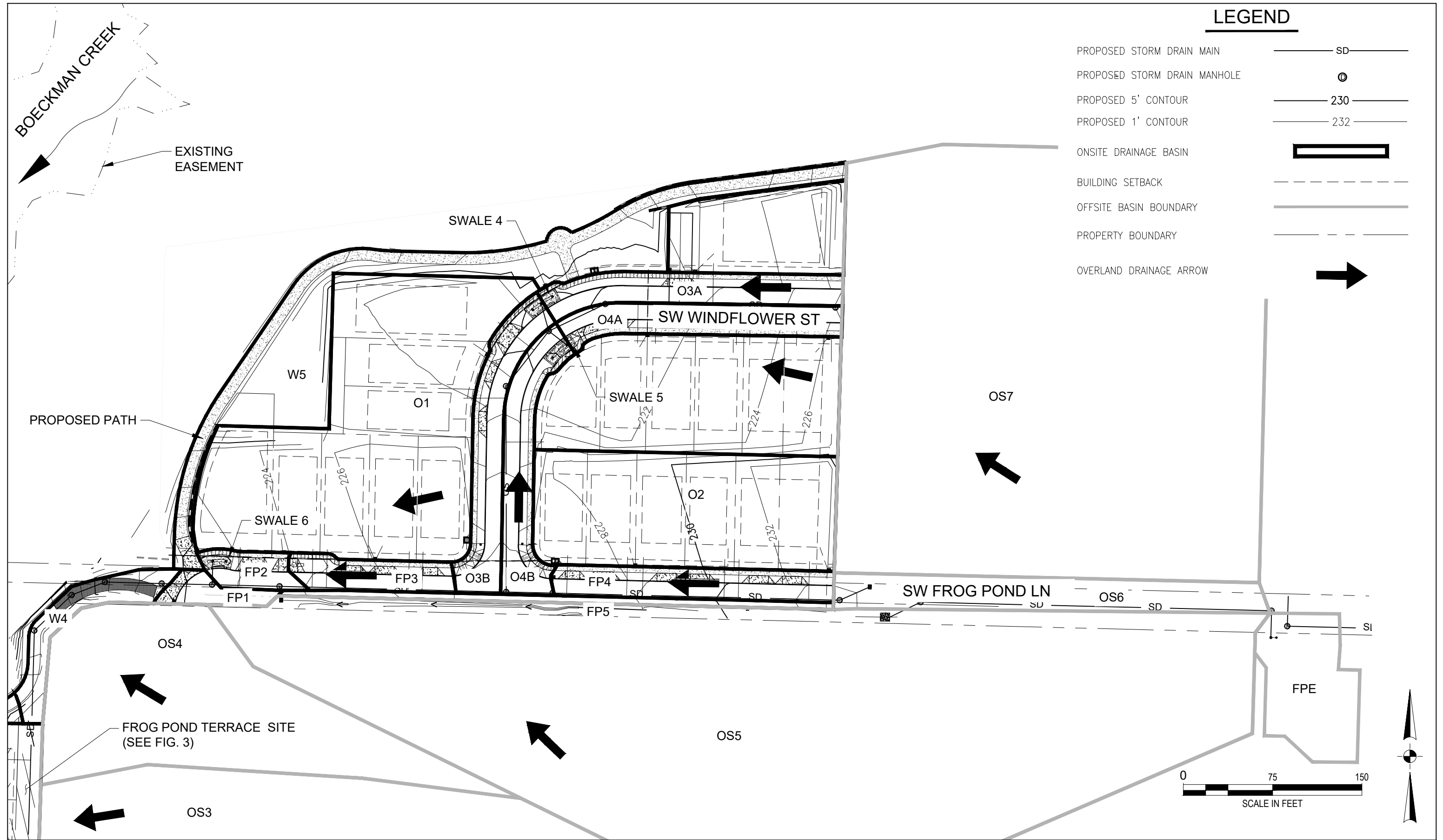

FROG POND OVERLOOK | PRELIMINARY DESIGN | PROPOSED CONDITIONS



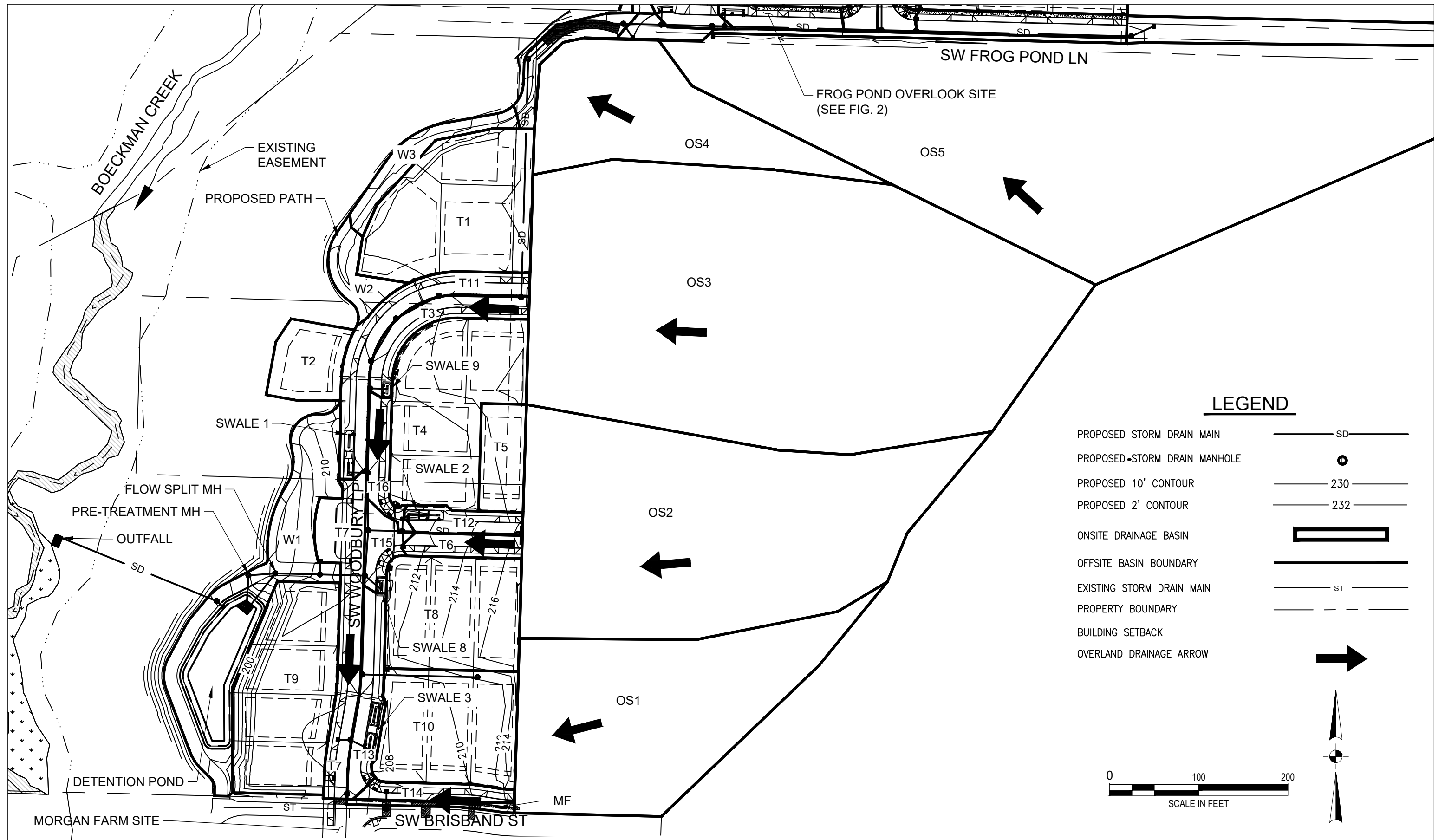

FROG POND TERRACE | PRELIMINARY DESIGN | PROPOSED CONDITIONS

FIG 3 | JANUARY 2023 | PROJECT NUMBER: 20015



Appendix A

Hydrology

Hydrologic Soil Group—Clackamas County Area, Oregon

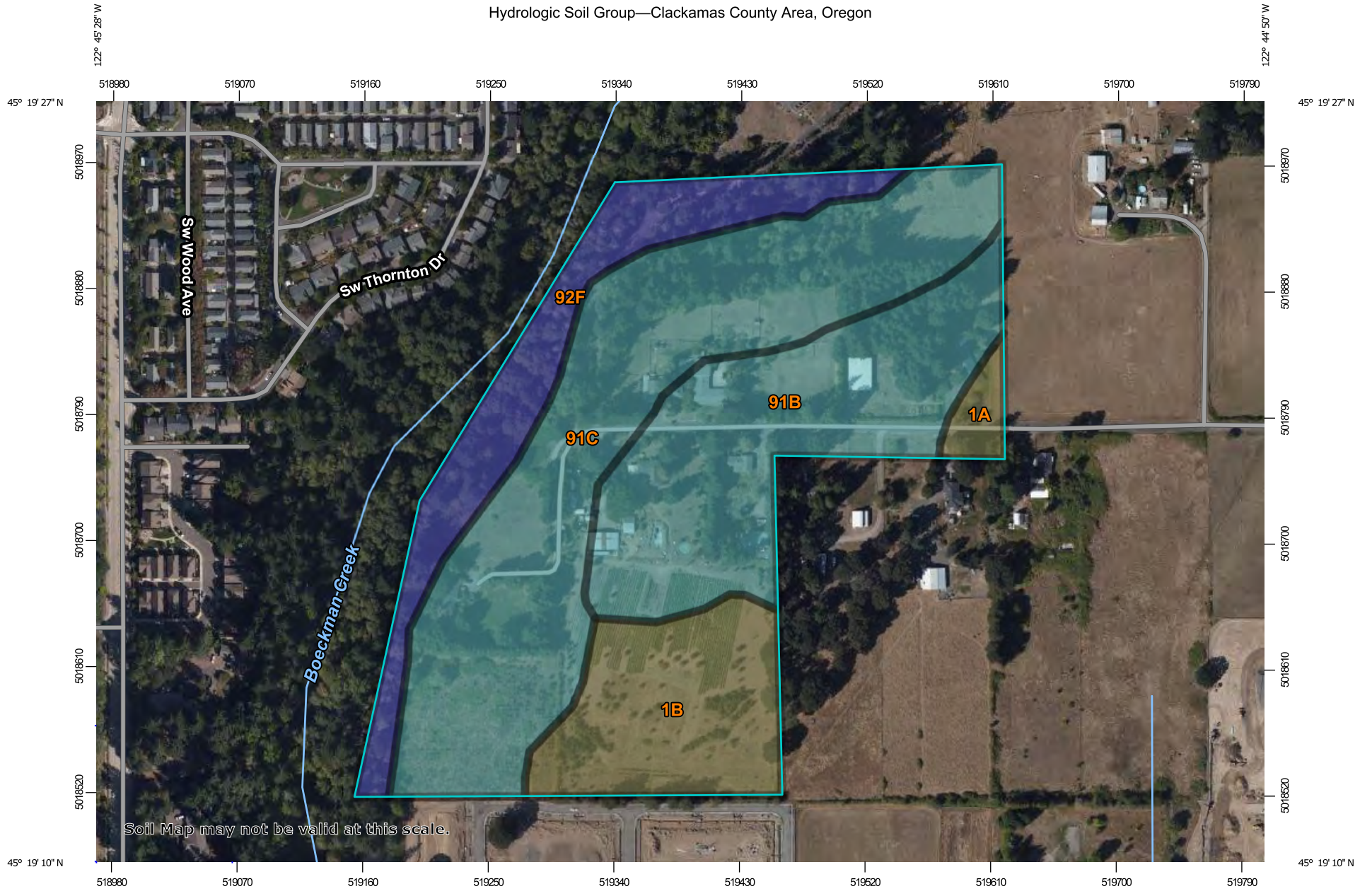

Soil Map may not be valid at this scale.

Map Scale: 1:3,830 if printed on A landscape (11" x 8.5") sheet.



Map projection: Web Mercator Corner coordinates: WGS84 Edge tics: UTM Zone 10N WGS84

MAP LEGEND

Area of Interest (AOI)









 Area of Interest (AOI)

Soils

Soil Rating Polygons





 A
 A/D
 B
 B/D
 C
 C/D
 D
 Not rated or not available

Soil Rating Lines

 A
 A/D
 B
 B/D
 C
 C/D
 D
 Not rated or not available

Soil Rating Points





 A
 A/D
 B
 B/D

 C
 C/D
 D
 Not rated or not available

Water Features

 Streams and Canals

Transportation

 Rails
 Interstate Highways
 US Routes
 Major Roads
 Local Roads

Background

 Aerial Photography

MAP INFORMATION

The soil surveys that comprise your AOI were mapped at 1:20,000.

Warning: Soil Map may not be valid at this scale.

Enlargement of maps beyond the scale of mapping can cause misunderstanding of the detail of mapping and accuracy of soil line placement. The maps do not show the small areas of contrasting soils that could have been shown at a more detailed scale.

Please rely on the bar scale on each map sheet for map measurements.

Source of Map: Natural Resources Conservation Service
 Web Soil Survey URL:
 Coordinate System: Web Mercator (EPSG:3857)

Maps from the Web Soil Survey are based on the Web Mercator projection, which preserves direction and shape but distorts distance and area. A projection that preserves area, such as the Albers equal-area conic projection, should be used if more accurate calculations of distance or area are required.

This product is generated from the USDA-NRCS certified data as of the version date(s) listed below.

Soil Survey Area: Clackamas County Area, Oregon
 Survey Area Data: Version 16, Jun 11, 2020

Soil map units are labeled (as space allows) for map scales 1:50,000 or larger.

Date(s) aerial images were photographed: Aug 1, 2019—Sep 12, 2019

The orthophoto or other base map on which the soil lines were compiled and digitized probably differs from the background imagery displayed on these maps. As a result, some minor shifting of map unit boundaries may be evident.

Hydrologic Soil Group

Map unit symbol	Map unit name	Rating	Acres in AOI	Percent of AOI
1A	Aloha silt loam, 0 to 3 percent slopes	C/D	0.6	1.9%
1B	Aloha silt loam, 3 to 6 percent slopes	C/D	5.1	15.1%
91B	Woodburn silt loam, 3 to 8 percent slopes	C	8.9	26.7%
91C	Woodburn silt loam, 8 to 15 percent slopes	C	13.9	41.3%
92F	Xerochrepts and Haploxerolls, very steep	B	5.0	15.0%
Totals for Area of Interest			33.5	100.0%

Description

Hydrologic soil groups are based on estimates of runoff potential. Soils are assigned to one of four groups according to the rate of water infiltration when the soils are not protected by vegetation, are thoroughly wet, and receive precipitation from long-duration storms.

The soils in the United States are assigned to four groups (A, B, C, and D) and three dual classes (A/D, B/D, and C/D). The groups are defined as follows:

Group A. Soils having a high infiltration rate (low runoff potential) when thoroughly wet. These consist mainly of deep, well drained to excessively drained sands or gravelly sands. These soils have a high rate of water transmission.

Group B. Soils having a moderate infiltration rate when thoroughly wet. These consist chiefly of moderately deep or deep, moderately well drained or well drained soils that have moderately fine texture to moderately coarse texture. These soils have a moderate rate of water transmission.

Group C. Soils having a slow infiltration rate when thoroughly wet. These consist chiefly of soils having a layer that impedes the downward movement of water or soils of moderately fine texture or fine texture. These soils have a slow rate of water transmission.

Group D. Soils having a very slow infiltration rate (high runoff potential) when thoroughly wet. These consist chiefly of clays that have a high shrink-swell potential, soils that have a high water table, soils that have a claypan or clay layer at or near the surface, and soils that are shallow over nearly impervious material. These soils have a very slow rate of water transmission.

If a soil is assigned to a dual hydrologic group (A/D, B/D, or C/D), the first letter is for drained areas and the second is for undrained areas. Only the soils that in their natural condition are in group D are assigned to dual classes.

Rating Options

Aggregation Method: Dominant Condition

Component Percent Cutoff: None Specified

Tie-break Rule: Higher



JOINS PANEL 0253



MAP SCALE 1" = 500'

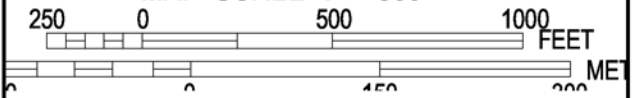

NFIP
NATIONAL FLOOD INSURANCE PROGRAM

PANEL 0234D

FIRM
FLOOD INSURANCE RATE MAP
CLACKAMAS COUNTY,
OREGON
AND INCORPORATED AREAS

PANEL 234 OF 1175
 (SEE MAP INDEX FOR FIRM PANEL LAYOUT)

CONTAINS:

<u>COMMUNITY</u>	<u>NUMBER</u>	<u>PANEL</u>	<u>SUFFIX</u>
CLACKAMAS COUNTY	415588	0234	D
WILSONVILLE, CITY OF	410025	0234	D

Notice to User: The **Map Number** shown below should be used when placing map orders; the **Community Number** shown above should be used on insurance applications for the subject community.



MAP NUMBER
41005C0234D
EFFECTIVE DATE
JUNE 17, 2008

Federal Emergency Management Agency

This is an official copy of a portion of the above referenced flood map. It was extracted using F-MIT On-Line. This map does not reflect changes or amendments which may have been made subsequent to the date on the title block. For the latest product information about National Flood Insurance Program flood maps check the FEMA Flood Map Store at www.msc.fema.gov

Drainage Basin Areas

20015 Frog Pond Terrace/Frog Pond Overlook

Existing Conditions:

Basin Name	Impervious Area		Pervious Area		Total Area	
	Total (sf)	Total (ac)	Total (sf)	Total (ac)	(sf)	(ac)
Site Total	28588	0.66	357,220	8.20	385,808	8.86
Terrace	3,451	0.08	214,018	4.91	217,469	4.99
Overlook	16,780	0.39	131,665	3.02	148,445	3.41
ROW	8,357	0.19	11,537	0.26	19,894	0.46
Offsite					641,947	14.74

Proposed Impervious Area per Lot

2,750 SF (2015 Public Works Stds 301.4.01)

Proposed Middle Housing Impervious Area per lot

2,420 SF (Overlook only)

Proposed Conditions:

40.0 lots HSG Type C

Basin	Treated By	Impervious Area				Pervious Area		Total Area	
		Roadway (sf)	Roof (sf)	Total (sf)	Total (ac)	(sf)	(ac)	(sf)	(ac)
Site Total		113,750	104,060	217,810	5.00	167,991	3.86	385,801	8.86
T1	Pond	2,281	8,250	10,531	0.24	15,541	0.36	26,072	0.60
T2	Pond	0	2,750	2,750	0.06	4,073	0.09	6,823	0.16
T3	Swale 9	5,035	0	5,035	0.12	851	0.02	5,886	0.14
T4	Pond	0	11,000	11,000	0.25	14,166	0.33	25,166	0.58
T5	Pond	0	2,750	2,750	0.06	3,313	0.08	6,063	0.14
T6	Pond	3,018	0	3,018	0.07	358	0.01	3,376	0.08
T7	Pond	11,203	0	11,203	0.26	358	0.01	11,561	0.27
T8	Pond	0	8,250	8,250	0.19	10,705	0.25	18,955	0.44
T9	Pond	0	11,000	11,000	0.25	13,021	0.30	24,021	0.55
T10**	Pond	0	8,250	8,250	0.19	11,390	0.26	19,640	0.45
T11	Swale 1	9,707	0	9,707	0.22	548	0.01	10,255	0.24
T12	Swale 2	2,693	0	2,693	0.06	889	0.02	3,582	0.08
T13	Swale 3	4,670	0	4,670	0.11	1,602	0.04	6,272	0.14
T14	MF Swale	2,924	0	2,924	0.07	386	0.01	3,310	0.08
T15	Swale 8	3,005	0	3,005	0.07	171	0.00	3,176	0.07
T16	Pond	3,439	0	3,439	0.08	348	0.01	3,787	0.09
O1	Pond	0	20,020	20,020	0.46	22,224	0.51	42,244	0.97
O2a	Pond	0	14,520	14,520	0.33	9,916	0.23	24,436	0.56
O2b	Pond	0	14,520	14,520	0.33	9,657	0.22	24,177	0.56
O3a	Swale 4	5,079	0	5,079	0.12	1,551	0.04	6,630	0.15
O3b	Swale 4	6,395	0	6,395	0.15	919	0.02	7,314	0.17
O4a	Swale 5	6,239	0	6,239	0.14	0	0.00	6,239	0.14
O4b	Swale 5	5,385	0	5,385	0.12	1,180	0.03	6,565	0.15
O5	Pond	1,101	2,750	3,851	0.09	6,347	0.15	10,198	0.23
MF	MF Swale	1,101	0	1,101	0.03	189	0.00	1,290	0.03
FP1	Pond	1,851	0	1,851	0.04	0	0.00	1,851	0.04
FP2	Swale 6	2,168	0	2,168	0.05	183	0.00	2,351	0.05
FP3	Swale 6	3,657	0	3,657	0.08	0	0.00	3,657	0.08
FP4	Pond	6,143	0	6,143	0.14	0	0.00	6,143	0.14
FP5	Pond	2,743	0	2,743	0.06	0	0.00	2,743	0.06
W1	Veg Corridor	9,862	0	9,862	0.23	16,617	0.38	26,479	0.61
W2	Veg Corridor	1,305	0	1,305	0.03	2,667	0.06	3,972	0.09
W3	Veg Corridor	2,398	0	2,398	0.06	2,472	0.06	4,870	0.11
W4	Veg Corridor	1,885	0	1,885	0.04	2,246	0.05	4,131	0.09
W5	Veg Corridor	8,463	0	8,463	0.19	14,103	0.32	22,566	0.52
Pond Total				135,839	3.12	121,992	2.80	261,856	6.01
Offsite Total				349,770	8.03	292,177	6.71	641,947	14.74
OS1	Offsite*			30,737	0.71	25,149	0.58	55,886	1.28
OS2	Offsite*			52,874	1.21	43,260	0.99	96,134	2.21
OS3	Offsite*			89,730	2.06	73,415	1.69	163,145	3.75
OS4	Offsite*			17,929	0.41	14,670	0.34	32,599	0.75
OS5	Offsite*			81,524	1.87	66,702	1.53	148,226	3.40
OS6	Offsite*			4,990	0.11	4,083	0.09	9,073	0.21
OS7	Offsite*			70,449	1.62	57,640	1.32	128,089	2.94
FPE	FPE RG/Swale			1,536	0.04	7,259	0.17	8,795	0.20

* For conveyance sizing offsite areas are assumed to be developed to 55% imperviousness

**Basin T10 pervious area drains to SDMH 2C and roofs drain to SDMH 6A

Appendix B

Geotechnical Report





HARDMAN GEOTECHNICAL SERVICES INC.

Practical, Cost-Effective
Engineering Solutions

December 15, 2021
HGSI Project No. 21-2824

Dan Grimberg / Kristi Hosea
West Hills Land Development
3330 NW Yeon Avenue, Suite 200
Portland, Oregon 97210

Via e-mail (pdf format); hard copies mailed upon request

**Subject: GEOTECHNICAL ENGINEERING AND INFILTRATION TESTING REPORT
FROG POND WEST-WEST
MARTIN, GEORGE AND ROSS PROPERTIES
WILSONVILLE, OREGON**

This report presents the results of a geotechnical engineering study conducted by Hardman Geotechnical Services Inc. (HGSI) for Frog Pond West-West (Martin, George and Ross Properties) in Wilsonville, Oregon (Figure 1). The purpose of this study was to evaluate subsurface conditions at the site and to provide geotechnical recommendations for site development.

SITE DESCRIPTION AND PROPOSED DEVELOPMENT

The project totals about 15.07 acres, as summarized below. Please note that the parcel addresses and acreages were taken from the Clackamas County GIS website and are only as accurate as the information provided.

Property	Tax Lot No.	Address	Acreage	House Constructed Date
Ross	31W12D 00700	7315 SW Frog Pond Ln	4.09	1964
George	31W12D 02801	7500 SW Frog Pond Ln	2.00	1972
Martin	31W12D 02800	No address	8.98	--

The Ross and George properties are currently occupied by residential homes, with several detached shops, garages and barns. Existing facilities are present only within the eastern, more flat-lying portion of the overall site. The areas surrounding the homes and other structures are landscaped with lawn, shrubbery and ornamental or fruit-bearing trees. No structures are present on the Martin property, which is overgrown with blackberries, etc. Along the western edge of the site is an area of steep slopes descending down to Boeckman Creek. The steep slope is vegetated with large deciduous and evergreen trees, and undergrowth.

December 15, 2021

HGSI Project No. 21-2824

Preliminary plans indicate the site will be developed into a 31-lot residential subdivision that will include two separate tracts with the intention of having one or both serve as water quality/detention facilities. The actual number of lots may vary as project design progresses. Site development will also include construction of on-site streets and underground utilities. All of the proposed development is within the eastern, flat to gently sloping portion of the site. The steep slopes in the western portion of the site are to remain open space.

In the northwest portion of the site, a temporary access easement extends near the top of the steep slope area. HGSI has studied potential landslide hazards and slope stability specific to this area, in a previous report (HGSI, 2021). The report concludes that the planned utility lines and temporary access way can be safely constructed, with a low-height soldier pile wall along the downslope (northwest) portion of the easement to protect against surficial soil sloughing/erosion.

REGIONAL GEOLOGY AND SEISMIC SETTING

The subject site lies within the heart of the Portland Basin, a broad structural depression situated between the Coast Range on the west and the Cascade Range on the east. The Portland Basin is a northwest-southwest trending structural basin produced by broad regional downwarping of the area. The Portland Basin is approximately 20 miles wide and 45 miles long and is filled with consolidated and unconsolidated sedimentary rocks of late Miocene, Pliocene and Pleistocene age.

Geologic maps indicate the subject site is underlain by Quaternary age (last 1.6 million years) Willamette Silt, fine flood deposits that mantles basalt bedrock (Madin, 1990). This generally consists of massive fine sand and silt deposited following repeated catastrophic flooding events in the Willamette Valley, the last of which occurred between 15,000 and 10,000 years ago. In localized areas, the light brown sandy silts include buried paleosols that developed between depositional events. Regionally, the total thickness of catastrophic flood deposits range from 5 feet to greater than 100 feet.

The Willamette Formation is underlain by residual soil formed by in place weathering of the underlying Columbia River Basalt Formation (Madin, 1990). The Miocene aged (about 14.5 to 16.5 million years ago) Columbia River Basalts are a thick sequence of lava flows which form the crystalline basement of the Tualatin Valley. The basalts are composed of dense, finely crystalline rock that is commonly fractured along blocky and columnar vertical joints. Individual basalt flow units typically range from 25 to 125 feet thick and interflow zones are typically vesicular, scoriaceous, brecciated, and sometimes include sedimentary rocks.

At least three major fault zones capable of generating damaging earthquakes are known to exist in the region. These include the Portland Hills Fault Zone, Gales Creek-Newberg-Mt. Angel Structural Zone, and the Cascadia Subduction Zone. These potential earthquake source zones are included in the determination of seismic design values for structures, as presented in the *Seismic Design* section. None of the known faults extend beneath the site.

FIELD EXPLORATION

Test Pits and Exploratory Hand Auger Borings

The site-specific exploration for this study was conducted on October 22, 2021 and December 3 and 9, 2021. On October 22, 2021 HGSI oversaw the excavation of two test pits using a medium-sized excavator in the area of the temporary easement (Figure 2). Test pits TP-3 through TP-11 were excavated on December 3, 2021, using a rubber-tired backhoe with extend-a-hoe attachment. Six hand auger borings (HA-1 through HA-6) were drilled on December 3 and 9, 2021 by HGSI staff using hand auger tools. Explorations were conducted at the approximate locations shown on the attached Site Plan, Figure 2.

Explorations were conducted under the full-time observation of HGSI personnel. Soil samples obtained from the borings were classified in the field and representative portions were placed in relatively air-tight plastic bags. These soil samples were then returned to the laboratory for further examination. Pertinent information including soil sample depths, stratigraphy, soil engineering characteristics, and groundwater occurrence was recorded. Soils were classified in general accordance with the Unified Soil Classification System.

Summary exploration logs are attached to this report. The stratigraphic contacts shown on the individual exploration logs represent the approximate boundaries between soil types. The actual transitions may be more gradual. The soil and groundwater conditions depicted are only for the specific dates and locations reported, and therefore, are not necessarily representative of other locations and times.

Infiltration Testing

On December 3, 2021, HGSI performed falling head infiltration tests using the open-hole method in hand auger borings HA-1, HA-2 and HA-3. The infiltration testing was performed by measuring the water level at one-minute intervals using HOBOTM data loggers, which measures water pressure corrected for temperature and barometric pressure. See attached HOBOTM water level data logger plot. The infiltration rate was determined based on the slope of the water depth line near the end of the test. Table 1 presents the results of the falling head infiltration tests.

Table 1. Summary of Infiltration Test Results

Boring	Depth (feet)	Soil Type	Infiltration Rate (in/hr)	Hydraulic Head Range during Testing (inches)
HA-1	5	Silt with Clay (ML)	0.6	7.8 – 6.6
HA-2	6	Fine Sandy Silt (ML)	1.1	15 - 14
HA-3	6	Fine Sandy Silt (ML)	1.2	14 – 13

The average of the three infiltration tests is 1.0 inches/hour. Reported values are ultimate and should be adjusted using an appropriate factor of safety for design purposes.

SUBSURFACE CONDITIONS

The following discussion is a summary of subsurface conditions encountered in our explorations. For more detailed information regarding subsurface conditions at specific exploration locations, refer to the attached hand auger logs. Also, please note that subsurface conditions can vary between exploration locations, as discussed in the *Uncertainty and Limitations* section below.

Soil

On-site soils are anticipated to consist of undocumented fill, topsoil, colluvium, and Willamette Formation soils as described below.

Undocumented Fill – In the northeast portion of the Ross Property, we encountered an area of undocumented fill. Test Pits TP-8, TP-9 and TP-10; and hand auger boring HA-3 encountered undocumented fill extending to 4.5 to 5 feet bgs. Between the fill and native soils a zone of old

topsoil was encountered in all three of the test pits. Undocumented fill consisted generally of soft silt with trace organics, and trace amounts of crushed rock and other erratic material.

Topsoil – Beginning at the surface level, all explorations encountered a zone of topsoil about 6 to 12 inches thick. The topsoil was generally comprised of soft, wet to moist dark brown organic silt. The upper roughly 6 inches of the topsoil appeared highly organic.

Colluvium – In TP-1 we encountered a zone of colluvium, comprised of stiff clayey silt with black and orange mottling. This material had a weathered, slightly disturbed appearance and extended to a depth of about 2.5 feet bgs. Colluvium, a zone of down-slope creep occurring due to weathering of surficial soils on natural slopes, was not encountered in the other test pits and hand auger borings.

Willamette Silt – Beneath the undocumented fill, topsoil and/or colluvium, all explorations encountered stiff to very stiff, moist to very moist, brown silt, clayey silt and silt with fine sand interpreted as Willamette Formation. The upper several feet of this unit exhibited orange and gray mottling. All explorations were terminated in the Willamette Silt unit, at depths ranging from 5 to 13 feet bgs.

Groundwater

Seepage was encountered in two of the deeper test pits, TP-4 and TP-7, at depths of about 13 and 10 feet respectively. During the field exploration, no seepage or static groundwater table was encountered in the other explorations. Based on nearby water well data, depth to static groundwater is at least 20 feet below the ground surface. Perched groundwater conditions often occur over fine-grained native deposits such as those beneath the site, particularly during the wet season. It is anticipated that groundwater conditions will vary depending on the season, local subsurface conditions, changes in site utilization, and other factors. The perched groundwater conditions reported above are for the specific date and locations indicated, and therefore may not necessarily be indicative of other times and/or locations.

CONCLUSIONS AND RECOMMENDATIONS

Results of this study indicate that the proposed development is geotechnically feasible, provided that the recommendations of this report are incorporated into the design and construction phases of the project. The proposed development avoids the steep slope area to the west; slope stability impacts are considered minimal as discussed in the *Slope Stability and Landslide Hazards* section. Recommendations are presented below regarding site preparation and undocumented fill removal, engineered fill, fill slope keying and benching, wet weather earthwork, spread footing foundations, below grade structural retaining walls, concrete slabs-on-grade, perimeter footing drains, seismic design, excavating conditions and utility trench backfill, stormwater infiltration systems, and erosion control considerations.

Slope Stability and Landslide Hazards

For the purpose of evaluating slope stability, we reviewed published geologic and hazard mapping, reviewed regional site topography and LIDAR images, performed a field reconnaissance, and evaluated subsurface soil conditions in exploratory test pits and hand auger borings.

Reconnaissance observations indicate that slope geomorphology at the site is generally smooth and uniform, consistent with stable slope conditions. No geomorphic evidence of prior slope instability (such as hummocky topography, benches or old scarps) was observed. No seeps or springs were observed on site.

Regional geologic mapping and the Oregon Department of Geology and Mineral Industries online landslide database (SLIDO, 2017) shows a small mapped landslide in the western portion of the Martin/George

December 15, 2021

HGSI Project No. 21-2824

property (Figure 3). This feature is mapped with low (<10%) confidence level, and historical (<150 years) in age. In our opinion this mapped ancient slide is not indicative of a significant slope stability hazard to the site, and is located far enough away from the proposed development that slope stability impacts are not anticipated.

In the northwest portion of the site between the Ross and Martin Properties (Figures 2 and 3), a temporary access easement extends near the top of the steep slope area. HGSI has studied potential landslide hazards and slope stability specific to this area, in a previous report (HGSI, 2021). The report concludes that the planned utility lines and temporary access way can be safely constructed, with a low-height soldier pile wall along the downslope (northwest) portion of the easement to protect against surficial soil sloughing/erosion.

The planned development does not extend onto the steep slope areas in the western portion of the site. Based on our observations and results of the slope stability evaluation, it is our opinion that no special design or construction provisions are needed to address slope issues on the site, with the exception of the soldier pile wall planned in conjunction with the temporary access easement (HGSI, 2021). The project will be designed and constructed per current building codes, City of Wilsonville requirements, and the current standard-of-practice in geotechnical engineering. As such, it is our opinion that adequate slope stability factors of safety will be maintained for both temporary construction, and long-term conditions.

We understand that the proposed storm water management plan may consist of flow through planters, stormwater ponds or swales, with overflow to an approved outlet. Significant infiltration of stormwater via stormwater chambers or dry wells is not proposed for this site based on soil conditions and infiltration test results. The planned storm water facilities are not anticipated to impact slope stability on site, or to create any unstable conditions. Storm water management systems should be designed such that potential overflow is discharged in a controlled manner away from structures and slopes, and all systems should include an adequate factor of safety.

Site Preparation and Undocumented Fill Removal

The areas of the site to be graded should first be cleared of vegetation and any loose debris; and debris from clearing should be removed from the site. Organic-rich topsoil should then be removed to competent native soils. We anticipate that the average depth of topsoil stripping will be 6 to 12 inches over most of the site. Deeper stripping / root picking may be needed in areas that are or were formerly treed. The final depth of stripping removal may vary depending on local subsurface conditions and the contractor's methods, and should be determined on the basis of site observations after the initial stripping has been performed. Stripped organic soil should be stockpiled only in designated areas or removed from the site and stripping operations should be observed and documented by HGSI. Existing subsurface structures (tile drains, old utility lines, septic leach fields, etc.) beneath areas of proposed structures and pavement should be removed and the excavations backfilled with engineered fill.

Undocumented fill was encountered in the northeast portion of the Ross Property, in TP-8, TP-9 and TP-10; and HA-3, at depths of about 4.5 to 5 feet bgs. There is potential for old fills to be present on site in areas beyond our explorations. Where encountered beneath proposed structures, pavements, or other settlement-sensitive improvements, undocumented fill should be removed down to firm inorganic native soils and the removal area backfilled with engineered fill (see below). HGSI should observe removal excavations (if any) prior to fill placement to verify that overexcavations are adequate and an appropriate bearing stratum is exposed.

In construction areas, once stripping has been verified, the area should be ripped or tilled to a depth of 12 inches, moisture conditioned, and compacted in-place prior to the placement of engineered fill. Exposed subgrade soils should be evaluated by HGSI. For large areas, this evaluation is normally performed by

proof-rolling the exposed subgrade with a fully loaded scraper or dump truck. For smaller areas where access is restricted, the subgrade should be evaluated by probing the soil with a steel probe. Soft/loose soils identified during subgrade preparation should be compacted to a firm and unyielding condition or over-excavated and replaced with engineered fill, as described below. The depth of overexcavation, if required, should be evaluated by HGSI at the time of construction.

Engineered Fill

In general, we anticipate that on-site soils will be suitable for use as engineered fill in dry weather conditions, provided they are relatively free of organics and are properly moisture conditioned for compaction. Imported fill material must be approved by the geotechnical engineer prior to being imported to the site. Oversize material greater than 6 inches in size should not be used within 3 feet of foundation footings, and material greater than 12 inches in diameter should not be used in engineered fill.

Engineered fill should be compacted in horizontal lifts not exceeding 8 inches using standard compaction equipment. We recommend that engineered fill be compacted to at least 90 percent of the maximum dry density determined by ASTM D1557 (Modified Proctor) or equivalent. On-site soils may be wet or dry of optimum; therefore, we anticipate that moisture conditioning of native soil will be necessary for compaction operations.

Proper test frequency and earthwork documentation usually requires daily observation and testing during stripping, rough grading, and placement of engineered fill. Field density testing should conform to ASTM D2922 and D3017, or D1556. Engineered fill should be periodically observed and tested by the project geotechnical engineer or his representative. Typically, one density test is performed for at least every 2 vertical feet of fill placed or every 500 yd³, whichever requires more testing.

Fill Slope Keying and Benching

Engineered fill placed on slopes requires keying and benching. We recommend that cut and fill slopes for the project be planned no steeper than 2H:1V. Fill slopes constructed over sloping ground should be constructed in accordance with the Fill Slope Detail, Figure 4. For fill slopes constructed at 2H:1V or flatter, and comprised of engineered fill placed and compacted as recommended herein, we anticipate that adequate factors of safety against global failure will be maintained.

Prior to placing compacted fill against the existing natural slopes, all loose undocumented fill, topsoil, and soft soils must first be removed. Adequate benching must be maintained. Fill slope keyways should be constructed with a minimum depth of 2 feet and minimum width of H/3 (10 feet minimum), where H equals the vertical height between the base and top of the fill slope. Both benches and keyways should be roughly horizontal in the down slope direction. A subdrain should be incorporated in the fill slope keyway, and HGSI should observe the keyway excavations prior to the placement of fill.

Measures should be taken to prevent surficial instability and/or erosion of embankment material. This can be accomplished by conscientious compaction of the embankment fills all the way out to the slope face, by maintaining adequate drainage, and planting the slope face as soon as possible after construction. To achieve the specified relative compaction at the slope face, it may be necessary to overbuild the slopes several feet, and then trim back to design finish grade. In our experience, compaction of slope faces by “track-walking” is generally ineffective and is therefore not recommended.

Wet Weather Earthwork

The on-site soils are moisture sensitive and may be difficult to handle or traverse with construction equipment during periods of wet weather. Earthwork is typically most economical when performed under dry weather conditions. Earthwork performed during the wet-weather season will probably require

expensive measures such as cement treatment or imported granular material to compact fill to the recommended engineering specifications. If earthwork is to be performed or fill is to be placed in wet weather or under wet conditions when soil moisture content is difficult to control, the following recommendations should be incorporated into the contract specifications.

- Earthwork should be performed in small areas to minimize exposure to wet weather. Excavation or the removal of unsuitable soils should be followed promptly by the placement and compaction of clean engineered fill. The size and type of construction equipment used may have to be limited to prevent soil disturbance. Under some circumstances, it may be necessary to excavate soils with a backhoe to minimize subgrade disturbance caused by equipment traffic;
- The ground surface within the construction area should be graded to promote run-off of surface water and to prevent the ponding of water;
- Material used as engineered fill should consist of clean, granular soil containing less than about 7 percent fines. The fines should be non-plastic. Alternatively, cement treatment of on-site soils may be performed to facilitate wet weather placement;
- The ground surface within the construction area should be sealed by a smooth drum vibratory roller, or equivalent, and under no circumstances should be left uncompacted and exposed to moisture. Soils which become too wet for compaction should be removed and replaced with clean granular materials;
- Excavation and placement of fill should be observed by the geotechnical engineer to verify that all unsuitable materials are removed and suitable compaction and site drainage is achieved; and
- Bales of straw and/or geotextile silt fences should be strategically located to control erosion.

If cement or lime treatment is used to facilitate wet weather construction, HGSI should be contacted to provide additional recommendations and field monitoring

Spread Footing Foundations

Shallow, conventional isolated or continuous spread footings may be used to support the proposed structures, provided they are founded on competent native soils, or compacted engineered fill placed directly upon the competent native soils. We recommend a maximum allowable bearing pressure of 2,000 pounds per square foot (psf) for designing spread footings bearing on undisturbed native soils or engineered fill. The recommended maximum allowable bearing pressure may be increased by a factor of 1.33 for short term transient conditions such as wind and seismic loading. Exterior footings should be founded at least 18 inches below the lowest adjacent finished grade. Minimum footing widths should be determined by the project engineer/architect in accordance with applicable design codes.

Assuming construction is accomplished as recommended herein, and for the foundation loads anticipated, we estimate total settlement of spread foundations of less than about 1 inch and differential settlement between two adjacent load-bearing components supported on competent soil of less than about ½ inch. We anticipate that the majority of the estimated settlement will occur during construction, as loads are applied.

Wind, earthquakes, and unbalanced earth loads will subject the proposed structure to lateral forces. Lateral forces on a structure will be resisted by a combination of sliding resistance of its base or footing on the underlying soil and passive earth pressure against the buried portions of the structure. For use in design, a coefficient of friction of 0.5 may be assumed along the interface between the base of the footing and subgrade soils. Passive earth pressure for buried portions of structures may be calculated using an equivalent fluid weight of 390 pounds per cubic foot (pcf), assuming footings are cast against dense, natural soils or engineered fill. The recommended coefficient of friction and passive earth pressure values do not include a

safety factor. The upper 12 inches of soil should be neglected in passive pressure computations unless it is protected by pavement or slabs on grade.

Footings excavations should be trimmed neat and the bottom of the excavation should be carefully prepared. Loose, wet or otherwise softened soil should be removed from the footing excavation prior to placing reinforcing steel bars. HGSI should observe foundation excavations prior to placing crushed rock, to verify that adequate bearing soils have been reached. Due to the high moisture sensitivity of on-site soils, construction during wet weather may require overexcavation of footings and backfill with compacted, crushed aggregate.

Below-Grade Cantilever Concrete Retaining Walls

Recommendations are provided below for design of concrete retaining walls. Footings for below-grade cantilever concrete walls should be designed using the 2,000 psf allowable soil bearing pressure recommended in the *Spread Footing Foundations* section. Lateral earth pressures against below-grade retaining walls will depend upon the inclination of any adjacent slopes, type of backfill, degree of wall restraint, method of backfill placement, degree of backfill compaction, drainage provisions, and magnitude and location of any adjacent surcharge loads. At-rest soil pressure is exerted on a retaining wall when it is restrained against rotation. In contrast, active soil pressure will be exerted on a wall if its top is allowed to rotate or yield a distance of roughly 0.001 times its height or greater.

Table 2 below provides recommended lateral earth pressure values for unrestrained and restrained walls, for both level backfill conditions and 2H:1V (Horizontal:Vertical) sloping ground conditions at the top of the wall. These values assume that the recommended drainage provisions are incorporated, and hydrostatic pressures are not allowed to develop against the wall.

Table 2. Recommended Lateral Earth Pressures for Below-Grade Structural Walls

Earth Pressure Condition	Level at Top of Wall	2H:1V Slope at Top of Wall
Active (unrestrained wall)	35	54
At-rest (restrained wall)	55	74

During a seismic event, lateral earth pressures acting on below-grade structural walls will increase by an incremental amount that corresponds to the earthquake loading. Based on the Mononobe-Okabe equation and peak horizontal accelerations appropriate for the site location, seismic loading should be modeled using the active or at-rest earth pressures recommended above, plus an incremental rectangular-shaped seismic load of magnitude 5H, where H is the total height of the wall.

We assume relatively level ground surface below the base of the walls. As such, we recommend passive earth pressure of 390 pcf for use in design, assuming wall footings are cast against competent native soils or engineered fill. If the ground surface slopes down and away from the base of any of the walls, a lower passive earth pressure should be used and HGSI should be contacted for additional recommendations.

A coefficient of friction of 0.5 may be assumed along the interface between the base of the wall footing and subgrade soils. The recommended coefficient of friction and passive earth pressure values do not include a safety factor, and an appropriate safety factor should be included in design. The upper 12 inches of soil should be neglected in passive pressure computations unless it is protected by pavement or slabs on grade.

The above recommendations for lateral earth pressures assume that the backfill behind the subsurface walls will consist of properly compacted structural fill, and no adjacent surcharge loading. If the walls will be subjected to the influence of surcharge loading within a horizontal distance equal to or less than the height of the wall, the walls should be designed for the additional horizontal pressure. For uniform surcharge pressures, a uniformly distributed lateral pressure of 0.3 times the surcharge pressure should be added.

The recommended equivalent fluid densities assume a free-draining condition behind the walls so that hydrostatic pressures do not build up. This can be accomplished by placing a 12-inch wide zone of crushed drain rock containing less than 5 percent fines against the walls. A 3-inch minimum diameter perforated, plastic drain pipe should be installed at the base of the walls and connected to a sump to remove water from the crushed drain rock zone. The drain pipe should be wrapped in filter fabric (Mirafi 140N or other as approved by the geotechnical engineer) to minimize clogging. The above drainage measures are intended to remove water from behind the wall to prevent hydrostatic pressures from building up. Additional drainage measures may be specified by the project architect or structural engineer, for damp-proofing or other reasons.

HGSI should be contacted during construction to verify subgrade strength in wall keyway excavations, to verify that backslope soils are in accordance with our assumptions, and to take density tests on the wall backfill materials.

Concrete Slabs-on-Grade

Preparation of areas beneath concrete slab-on-grade floors should be performed as recommended in the *Site Preparation* section. Care should be taken during excavation for foundations and floor slabs, to avoid disturbing subgrade soils. If subgrade soils have been adversely impacted by wet weather or otherwise disturbed, the surficial soils should be scarified to a minimum depth of 8 inches, moisture conditioned to within about 3 percent of optimum moisture content, and compacted to engineered fill specifications. Alternatively, disturbed soils may be removed and the removal zone backfilled with additional crushed rock. For evaluation of the concrete slab-on-grade floors using the beam on elastic foundation method, a modulus of subgrade reaction of 200 kcf (115 pci) should be assumed for the soils anticipated at subgrade depth. This value assumes the concrete slab system is designed and constructed as recommended herein, with a minimum thickness of crushed rock of 8 inches beneath the slab.

Interior slab-on-grade floors should be provided with an adequate moisture break. The capillary break material should consist of ODOT open graded aggregate per ODOT Standard Specifications 02630-2. The minimum recommended thickness of capillary break materials on re-compacted soil subgrade is 8 inches. The total thickness of crushed aggregate will be dependent on the subgrade conditions at the time of construction, and should be verified visually by proof-rolling. Under-slab aggregate should be compacted to at least 90% of its maximum dry density as determined by ASTM D1557 or equivalent.

In areas where moisture will be detrimental to floor coverings or equipment inside the proposed structure, appropriate vapor barrier and damp-proofing measures should be implemented. A commonly applied vapor barrier system consists of a 10-mil polyethylene vapor barrier placed directly over the capillary break material. Other damp/vapor barrier systems may also be feasible. Appropriate design professionals should be consulted regarding vapor barrier and damp proofing systems, ventilation, building material selection, radon and mold prevention issues, which are outside HGSI's area of expertise.

Perimeter Footing Drains

Due to the potential for perched surface water above fine grained deposits such as those encountered at the site, we recommend the outside edge of perimeter footings be provided with a drainage system consisting of 3-inch minimum diameter perforated PVC pipe embedded in a minimum of 1 ft³ per lineal foot of clean, free-draining sand and gravel or 1"- 1/4" drain rock. The drain pipe and surrounding drain rock should be

wrapped in non-woven geotextile (Mirafi 140N, or approved equivalent) to minimize the potential for clogging and/or ground loss due to piping. Water collected from the footing drains should be directed into the local storm drain system or other suitable outlet. A minimum 0.5 percent fall should be maintained throughout the drain and non-perforated pipe outlet. The footing drains should include clean-outs to allow periodic maintenance and inspection.

Down spouts and roof drains should collect roof water in a system separate from the footing drains in order to reduce the potential for clogging. Roof drain water should be directed to an appropriate discharge point well away from structural foundations. Grades should be sloped downward and away from buildings to reduce the potential for ponded water near structures.

Seismic Design

Structures should be designed to resist earthquake loading in accordance with the methodology described in the current Oregon Residential Specialty Code (ORSC). We recommend Site Class D (Stiff Soils) be used for design per the ORSC. Design values determined for the site using the ASCE 7-16 Hazard Tool are summarized on Table 3, for Risk Category II.

Table 3. Recommended Earthquake Ground Motion Parameters (ASCE 7-16)

Parameter	Value
Location (Lat, Long), degrees	45.3211, -122.7494
Mapped Spectral Acceleration Values (MCE, Site Class B):	
Short Period, S_s	0.82 g
1.0 Sec Period, S_1	0.381 g
Design Values for Site Class D (Stiff Soils):	
Peak Ground Acceleration PGA_M	0.458
F_a	1.172
$SD_s = 2/3 \times F_a \times S_s$	0.641 g
Seismic Design Category (2021 ORSC)	D_0

Soil liquefaction is a phenomenon wherein saturated soil deposits temporarily lose strength and behave as a liquid in response to earthquake shaking. Soil liquefaction is generally limited to loose, granular soils located below the water table. Following development, on-site soils will consist predominantly of stiff to very stiff silt which are not considered susceptible to liquefaction. Therefore, it is our opinion that special design or construction measures are not required to mitigate the effects of liquefaction.

Excavating Conditions and Utility Trench Backfill

We anticipate that on-site soils can be excavated using conventional heavy equipment such as scrapers and trackhoes to depths of 13 feet and likely greater. Maintenance of safe working conditions, including temporary excavation stability, is the responsibility of the contractor. Actual slope inclinations at the time of construction should be determined based on safety requirements and actual soil and groundwater conditions. All temporary cuts in excess of 4 feet in height should be sloped in accordance with U.S. Occupational Safety and Health Administration (OSHA) regulations (29 CFR Part 1926), or be shored. The existing native soils classify as Type B Soil and temporary excavation side slope inclinations as steep as 1H:1V may be assumed for planning purposes. This cut slope inclination is applicable to excavations above the water table only.

Perched groundwater conditions often occur over fine-grained native deposits such as those beneath the site, particularly during the wet season. If encountered, the contractor should be prepared to implement an appropriate dewatering system for installation of the utilities. At this time, we anticipate that dewatering systems consisting of ditches, sumps and pumps would be adequate for control of groundwater where encountered during construction conducted during the dry season. Regardless of the dewatering system used, it should be installed and operated such that in-place soils are prevented from being removed along with the groundwater.

Vibrations created by traffic and construction equipment may cause some caving and raveling of excavation walls. In such an event, lateral support for the excavation walls should be provided by the contractor to prevent loss of ground support and possible distress to existing or previously constructed structural improvements.

Utility trench backfill should consist of ¾"-0 crushed rock, compacted to at least 95% of the maximum dry density obtained by Modified Proctor (ASTM D1557) or equivalent. Initial backfill lift thicknesses for a ¾"-0 crushed aggregate base may need to be as great as 4 feet to reduce the risk of flattening underlying flexible pipe. Subsequent lift thickness should not exceed 1 foot. If imported granular fill material is used, then the lifts for large vibrating plate-compaction equipment (e.g. hoe compactor attachments) may be up to 2 feet, provided that proper compaction is being achieved and each lift is tested. Use of large vibrating compaction equipment should be carefully monitored near existing structures and improvements due to the potential for vibration-induced damage.

Adequate density testing should be performed during construction to verify that the recommended relative compaction is achieved. Typically, one density test is taken for every 4 vertical feet of backfill on each 200-lineal-foot section of trench.

Stormwater Infiltration Facilities

Based on results of the soil infiltration testing, soils on site exhibit low infiltration rates especially in the presence of perched water or static groundwater. Infiltration rates ranged from 0.6 to 1.2 inches/hour as summarized on Table 1. We recommend shallow systems in the range of 2 to 5 feet bgs be designed using an infiltration rate of **0.6 inches/hour**. This is slightly less than the average test value of 1.0 inches/hour, but we feel 0.3 inches/hour is more representative of overall site conditions. Also, please note that the potential for infiltration of stormwater will be reduced during the wet season due to saturated soils / perched water conditions over much of the site. We do not believe the site is well suited for use of deeper infiltration facilities such as dry wells due to the very low-permeability site soils, and perched water conditions.

The designer should select an appropriate infiltration value based on our test results and the location of the proposed infiltration facility. The recommended infiltration rates do not incorporate a factor of safety. For the design infiltration rate, we recommend a factor of safety of at least 2.0. Greater factors of safety may be required by the governing agency.

Infiltration test methods and procedures attempt to simulate the as-built conditions of the planned disposal system. However, due to natural variations in soil properties, actual infiltration rates may vary from the measured and/or recommended design rates. All systems should be constructed such that potential overflow is discharged in a controlled manner away from structures, and all systems should include an adequate factor of safety. Infiltration rates presented in this report should not be applied to inappropriate or complex hydrological models such as a closed basin without extensive further studies.

Erosion Control Considerations

During our field exploration program, we did not observe soil types that would be considered highly susceptible to erosion. Erosion at the site during construction can be minimized by implementing the project erosion control plan, which should include judicious use of straw, bio-bags, silt fences, or other appropriate technology. Where used, erosion control devices should be in place and remain in place throughout site preparation and construction. Areas of exposed soil requiring immediate and/or temporary protection against exposure should be covered with either mulch or erosion control netting/blankets.

UNCERTAINTIES AND LIMITATIONS

We have prepared this report for the owner and his/her consultants for use in design of this project only. This report should not be construed as a warranty of the subsurface conditions. Experience has shown that soil and groundwater conditions can vary significantly over small distances. Inconsistent conditions can occur between explorations that may not be detected by a geotechnical study. If, during future site operations, subsurface conditions are encountered which vary appreciably from those described herein, HGSI should be notified for review of the recommendations of this report, and revision of such if necessary.

Sufficient geotechnical monitoring, testing and consultation should be provided during construction to confirm that the conditions encountered are consistent with those indicated by explorations. Recommendations for design changes will be provided should conditions revealed during construction differ from those anticipated, and to verify that the geotechnical aspects of construction comply with the contract plans and specifications.

Within the limitations of scope, schedule and budget, HGSI executed these services in accordance with generally accepted professional principles and practices in the field of geotechnical engineering at the time the report was prepared. No warranty, expressed or implied, is made. The scope of our work did not include environmental assessments or evaluations regarding the presence or absence of wetlands or hazardous or toxic substances in the soil, surface water, or groundwater at this site.



We appreciate this opportunity to be of service.

Sincerely,

HARDMAN GEOTECHNICAL SERVICES INC.

Scott L. Hardman, P.E., G.E.
Geotechnical Engineer



EXPIRES: 06-30-2023

- Attachments:
- References
 - Figure 1 – Vicinity Map
 - Figure 2 – Site Plan
 - Figure 3 – DOGAMI LiDAR Mapping
 - Figure 4 – Fill Slope Detail
 - Logs of Test Pits TP-1 through TP-11
 - Logs of Hand Auger Borings HA-1 through HA-6
 - Infiltration Test Data Plots (3 Pages)
 - ASCE Seismic Design Hazards Report (3 Pages)



REFERENCES

- Hardman Geotechnical Services Inc., 2021, *Geotechnical Evaluation of Landslide Hazards and Slope Stability; Proposed Underground Utility Easement; Frog Pond West-West; Martin, George and Ross Properties; Wilsonville, Oregon*; consultant report dated October 28.
- Madin, I.P., 1990, Earthquake hazard geology maps of the Portland metropolitan area, Oregon: Oregon Department of Geology and Mineral Industries Open-File Report 0-90-2, scale 1:24,000, 22 p.
- Schlicker, H.G. and Finlayson, C.T., 1979, Geology and geologic hazards of northwest Clackamas County, Oregon Department of Geology and Mineral Industries, Bulletin 99, 1:24,000
- Yeats, R.S., Graven, E.P., Werner, K.S., Goldfinger, C., and Popowski, T., 1996, Tectonics of the Willamette Valley, Oregon: in *Assessing earthquake hazards and reducing risk in the Pacific Northwest*, Vol. 1: U.S. Geological Survey Professional Paper 1560, P. 183-222, 5 plates, scale 1:100,000.



**HARDMAN
GEOTECHNICAL
SERVICES INC.**

Practical, Cost-Effective Geotechnical Solutions

SITE PLAN AND EXPLORATION LOCATIONS



Legend

TP-X Backhoe Test Pit Designation and
 Approximate Location

Base Map by Portland Maps

Project: Frog Pond West West
 Wilsonville, Oregon

Project No. 20-2642

FIGURE 2



**HARDMAN
GEOTECHNICAL
SERVICES INC.**

10110 SW Nimbus Avenue, Suite B-5
Portland, Oregon 97223
Tel: (503) 530-8076

Practical, Cost-Effective Geotechnical Solutions

DOGAMI LiDAR MAPPING

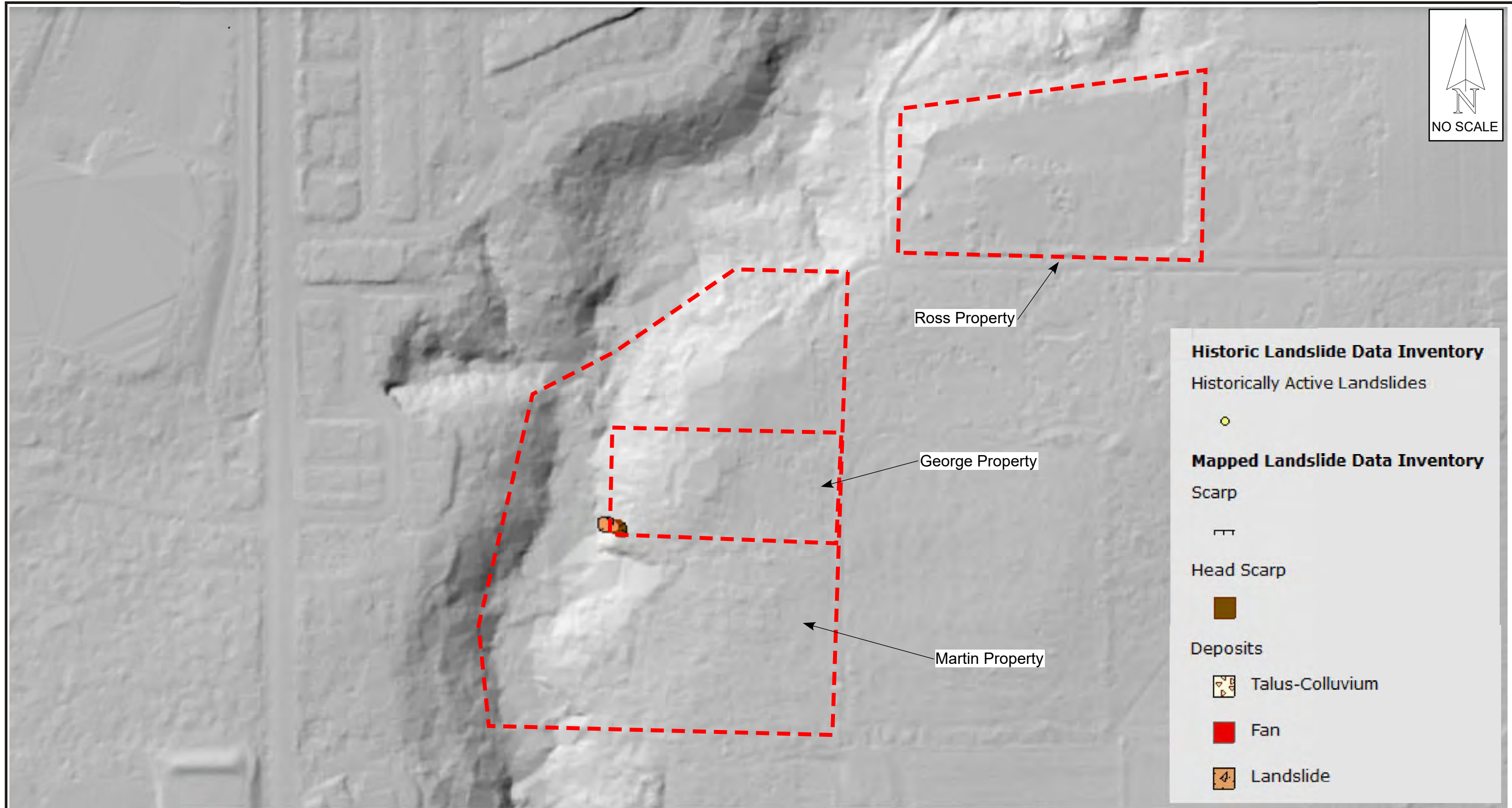
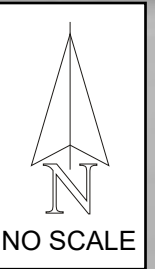

LEGEND



Approximate Site Boundary

Base Map from DOGAMI SLIDO Website

Project No. 21-2824

Frog Pond West-West
Wilsonville, Oregon

FIGURE 3



TYPICAL KEYWAY, BENCHING & FILL SLOPE DESIGN

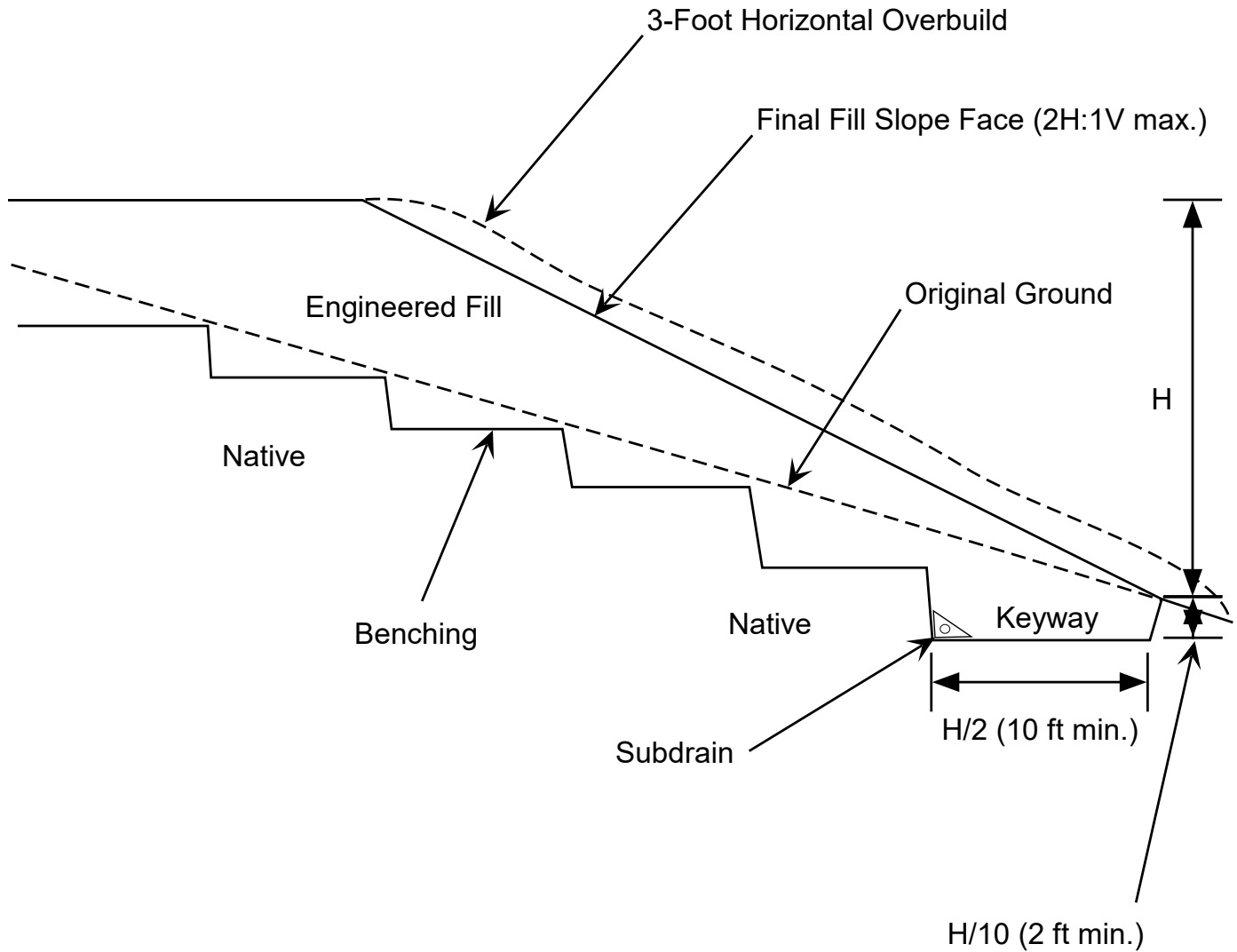

Recommended subdrain is minimum 3-inch-diameter ADS Heavy Duty grade (or equivalent), perforated plastic pipe enveloped in a minimum of 3 cubic feet per lineal foot of 2" to 1/2" open-graded gravel drain rock wrapped with geotextile filter fabric (Mirafi 140N or equivalent).

LOG OF BACKHOE TEST PIT

Project: Frog Pond West West
Wilsonville, Oregon

Project No. 21-2824

Test Pit No. **TP - 1**

Depth (ft)	Pocket Penetrometer (tons/ft ²)	Sample Interval	Sample Designation	Moisture Content (%)	Groundwater	Material Description
1						Soft, Organic SILT, dark brown, moist, many roots throughout (topsoil)
2	3.0					Stiff, Clayey SILT, light yellowish brown with black and orange mottling, moist, weathered (Colluvium)
3	3.5					Very stiff to hard, Clayey SILT, yellowish brown with trace mottling in upper portion of unit only, slightly moist, unweathered and intact
4	>4.5					
5	>>4.5					
6						
7						
8						Very difficult excavating at 8 feet due to hard materials.
9						Test pit terminated at 8 feet No caving of pit side walls No groundwater or seepage encountered
10						
11						
12						
13						
14						
15						
16						

HCSI HARDMAN
GEOTECHNICAL
SERVICES INC.
Practical. Cost-Effective Geotechnical Solutions
10110 SW Nimbus Ave., Suite B-5
Portland, OR 97223
(503) 530-8076

LEGEND



S-#



Soil Sample Depth
Interval and Designation

Water Level at
Time of Excavation

Date Excavated: 10/22/2021

Logged By: SLH

Surface Elevation: Unknown

LOG OF BACKHOE TEST PIT

Project: Frog Pond West West
Wilsonville, Oregon

Project No. 21-2824

Test Pit No. **TP - 2**

Depth (ft)	Pocket Penetrometer (tons/ft ²)	Sample Interval	Sample Designation	Moisture Content (%)	Groundwater	Material Description
1						Soft, Organic SILT, dark brown, moist, abundant grass roots (topsoil) ----- Dense, silty angular gravel, gray, moist (old driveway or pull-out area) -----
2						Very stiff to hard, Clayey SILT, yellowish brown with trace mottling in upper portion of unit only, slightly moist, unweathered and intact
3						
4						
5						
6						
7						
8						Grades to Clayey Silt with some fine sand at 8 feet
9						
10						
11						Test pit terminated at 10 feet No caving of pit sidewalls No groundwater or seepage encountered
12						
13						
14						
15						
16						

HCSI **HARDMAN GEOTECHNICAL SERVICES INC.**
Practical. Cost-Effective Geotechnical Solutions
 10110 SW Nimbus Ave., Suite B-5
 Portland, OR 97223
 (503) 530-8076

LEGEND



S-#



Soil Sample Depth Interval and Designation

Water Level at Time of Excavation

Date Excavated: 10/22/2021
 Logged By: SLH
 Surface Elevation: Unknown

LOG OF BACKHOE TEST PIT

Project: Frog Pond West West
Wilsonville, Oregon



Project No. 21-2824

Test Pit No. **TP - 3**

Depth (ft)	Pocket Penetrometer (tons/ft ²)	Sample Interval	Sample Designation	Moisture Content (%)	Groundwater	Material Description
1						Moist, soft, dark brown, SILT (OL), heavy organics with grass and roots in the top 6 inches. [Topsoil]
2						Moist, medium stiff, brown and light grey, clayey SILT (ML), orange and dark brown mottling. [Willamette Formation]
3						
4	4.2					Moist, stiff to very stiff, brown, sandy SILT (ML) with clay, orange and dark brown mottling, heavily micaceous. [Willamette Formation]
5						
6						
7						
8			S-1			
9						
10						<i>Test Pit terminated at 10 feet No groundwater or seepage encountered No caving</i>
11						
12						
13						
14						
15						
16						

HCSI **HARDMAN GEOTECHNICAL SERVICES INC.**
 Practical. Cost-Effective. Geotechnical Solutions
 10110 SW Nimbus Ave., Suite B-5
 Portland, OR 97223
 (503) 530-8076

LEGEND

 S-# 
 Soil Sample Depth Interval and Designation Water Level at Time of Excavation

Date Excavated: 12/3/2021
 Logged By: CSH
 Surface Elevation: Unknown

LOG OF BACKHOE TEST PIT

Project: Frog Pond West West
Wilsonville, Oregon

Project No. 21-2824

Test Pit No. **TP - 4**

Depth (ft)	Pocket Penetrometer (tons/ft ²)	Sample Interval	Sample Designation	Moisture Content (%)	Groundwater	Material Description
1						Moist, soft, dark brown, SILT (OL), heavy organics with grass and roots in the top 6 inches. [Topsoil]
2						Moist, stiff to very stiff, brown, sandy SILT (ML) with clay, orange and dark brown mottling, micaceous. [Willamette Formation]
3						
4						
5						
6						
7						
8						
9						
10						
11						Saturated, medium stiff, brown, sandy SILT (ML) with clay, heavily micaceous. [Willamette Formation]
12						
13					▽	<i>Test Pit terminated at 13 feet</i> <i>Seepage observed in the bottom of the test pit</i> <i>No caving</i>
14						
15						
16						

HCSI HARDMAN
GEOTECHNICAL
SERVICES INC.
Practical. Cost-Effective Geotechnical Solutions
10110 SW Nimbus Ave., Suite B-5
Portland, OR 97223
(503) 530-8076

LEGEND



S-#



Soil Sample Depth
Interval and Designation

Water Level at
Time of Excavation

Date Excavated: 12/3/2021
Logged By: CSH
Surface Elevation: Unknown

LOG OF BACKHOE TEST PIT

Project: Frog Pond West West
Wilsonville, Oregon

Project No. 21-2824

Test Pit No. **TP - 5**

Depth (ft)	Pocket Penetrometer (tons/ft ²)	Sample Interval	Sample Designation	Moisture Content (%)	Groundwater	Material Description
1						Moist, soft, dark brown, SILT (OL), heavy organics [Topsoil]
2	3.0					Moist, medium stiff, brown and light grey, silty CLAY (CL), orange and dark brown mottling. [Willamette Formation]
3						Moist, stiff to very stiff, brown, sandy SILT (ML) with clay, orange and dark brown mottling. [Willamette Formation]
4						
5						
6						
7						
8						
9						
10						
11						<i>Test Pit terminated at 10 feet</i>
12						<i>No groundwater or seepage encountered</i>
13						<i>No caving</i>
14						
15						
16						

HCSI HARDMAN
GEOTECHNICAL
SERVICES INC.
Practical. Cost-Effective Geotechnical Solutions
10110 SW Nimbus Ave., Suite B-5
Portland, OR 97223
(503) 530-8076

LEGEND



S-#



Soil Sample Depth
Interval and Designation

Water Level at
Time of Excavation

Date Excavated: 12/3/2021

Logged By: CSH

Surface Elevation: Unknown

LOG OF BACKHOE TEST PIT

Project: Frog Pond West West
Wilsonville, Oregon

Project No. 21-2824

Test Pit No. **TP - 6**

Depth (ft)	Pocket Penetrometer (tons/ft ²)	Sample Interval	Sample Designation	Moisture Content (%)	Groundwater	Material Description
1						Moist, soft, dark brown, SILT (OL), heavy organics [Topsoil]
2						Moist, stiff, brown, clayey SILT (ML) with sand, orange and dark brown mottling. [Willamette Formation] Sandiness increasing with depth
3						
4						
5						
6						
7						Moist, stiff, brown, sandy SILT (ML), orange and dark brown mottling, slightly micaceous. [Willamette Formation]
8						
9						
10						
11						<i>Test Pit terminated at 10 feet</i> <i>No groundwater or seepage encountered</i> <i>No caving</i>
12						
13						
14						
15						
16						

HCSI **HARDMAN GEOTECHNICAL SERVICES INC.**
 Practical. Cost-Effective. Geotechnical Solutions
 10110 SW Nimbus Ave., Suite B-5
 Portland, OR 97223
 (503) 530-8076

LEGEND



S-#



Soil Sample Depth Interval and Designation

Water Level at Time of Excavation

Date Excavated: 12/3/2021
 Logged By: CSH
 Surface Elevation: Unknown

LOG OF BACKHOE TEST PIT

Project: Frog Pond West West
Wilsonville, Oregon

Project No. 21-2824

Test Pit No. **TP - 7**

Depth (ft)	Pocket Penetrometer (tons/ft ²)	Sample Interval	Sample Designation	Moisture Content (%)	Groundwater	Material Description
1						Moist, soft, dark brown, SILT (OL), heavy organics [Topsoil]
2						Moist, medium stiff, brown and light grey, silty CLAY (CL), orange and dark brown mottling. [Willamette Formation]
3						Moist, stiff to very stiff, brown, sandy SILT (ML) with clay, orange and dark brown mottling. [Willamette Formation]
4						
5						
6						
7						
8						
9						Very moist to saturated, medium stiff, brown, silty fine grained SAND (SM), heavily micaceous. [Willamette Formation]
10					▽	
11						
12						<i>Test Pit terminated at 12 feet Seepage observed around 10 feet bgs No caving</i>
13						
14						
15						
16						

HCSI **HARDMAN GEOTECHNICAL SERVICES INC.**
 Practical. Cost-Effective. Geotechnical Solutions
 10110 SW Nimbus Ave., Suite B-5
 Portland, OR 97223
 (503) 530-8076

LEGEND



S-#



Soil Sample Depth Interval and Designation

Water Level at Time of Excavation

Date Excavated: 12/3/2021
 Logged By: CSH
 Surface Elevation: Unknown

LOG OF BACKHOE TEST PIT

Project: Frog Pond West West
Wilsonville, Oregon

Project No. 21-2824

Test Pit No. **TP - 8**

Depth (ft)	Pocket Penetrometer (tons/ft ²)	Sample Interval	Sample Designation	Moisture Content (%)	Groundwater	Material Description
1						Moist, soft, dark brown, SILT (OL), heavy organics with grass and roots in the top 6 inches. [Topsoil]
2						Moist, soft, brown silt interbedded with dark brown silt and organics. Strata matrix is disturbed and there are some crushed rock fragments. [Undocumented Fill]
3						
4						Decomposing grass layer and buried topsoil
5						Moist, stiff to very stiff, brown, sandy SILT (ML) with clay, orange and dark brown mottling, micaceous. [Willamette Formation]
6						
7						
8						
9						
10						
11						<i>Test Pit terminated at 10 feet No groundwater or seepage encountered No caving</i>
12						
13						
14						
15						
16						

HCSI **HARDMAN GEOTECHNICAL SERVICES INC.**
 Practical. Cost-Effective. Geotechnical Solutions
 10110 SW Nimbus Ave., Suite B-5
 Portland, OR 97223
 (503) 530-8076

LEGEND



S-#



Soil Sample Depth Interval and Designation

Water Level at Time of Excavation

Date Excavated: 12/3/2021
 Logged By: CSH
 Surface Elevation: Unknown

LOG OF BACKHOE TEST PIT

Project: Frog Pond West West
Wilsonville, Oregon

Project No. 21-2824

Test Pit No. **TP - 9**

Depth (ft)	Pocket Penetrometer (tons/ft ²)	Sample Interval	Sample Designation	Moisture Content (%)	Groundwater	Material Description
1						Moist, soft, dark brown, SILT (OL), heavy organics with grass and roots in the top 6 inches. [Topsoil]
2						Moist, soft, brown silt interbedded with dark brown silt and organics. Strata matrix is disturbed and there are some crushed rock fragments. [Undocumented Fill]
3						
4	1.8					Decomposing grass layer and buried topsoil
5						Moist, stiff to very stiff, brown, sandy SILT (ML) with clay, orange and dark brown mottling, micaceous. [Willamette Formation]
6						
7						
8						
9						
10						
11						<i>Test Pit terminated at 10 feet No groundwater or seepage encountered No caving</i>
12						
13						
14						
15						
16						

HCSI HARDMAN
GEOTECHNICAL
SERVICES INC.
Practical. Cost-Effective Geotechnical Solutions
10110 SW Nimbus Ave., Suite B-5
Portland, OR 97223
(503) 530-8076

LEGEND



S-#



Soil Sample Depth
Interval and Designation

Water Level at
Time of Excavation

Date Excavated: 12/3/2021

Logged By: CSH

Surface Elevation: Unknown

LOG OF BACKHOE TEST PIT

Project: Frog Pond West West
Wilsonville, Oregon

Project No. 21-2824

Test Pit No. **TP - 10**

Depth (ft)	Pocket Penetrometer (tons/ft ²)	Sample Interval	Sample Designation	Moisture Content (%)	Groundwater	Material Description
1						Moist, soft, dark brown, SILT (OL), heavy organics with grass and roots in the top 6 inches. [Topsoil]
2						Moist, soft, dark brown silt with organics and fractured rock. [Undocumented Fill]
3						
4						
5						
6						Moist, stiff to very stiff, brown, sandy SILT (ML) with clay, orange and dark brown mottling, micaceous. [Willamette Formation]
7						
8						
9						
10						
11						<i>Test Pit terminated at 10 feet No groundwater or seepage encountered No caving</i>
12						
13						
14						
15						
16						

HCSI **HARDMAN GEOTECHNICAL SERVICES INC.**
 Practical. Cost-Effective. Geotechnical Solutions
 10110 SW Nimbus Ave., Suite B-5
 Portland, OR 97223
 (503) 530-8076

LEGEND



S-#



Soil Sample Depth Interval and Designation

Water Level at Time of Excavation

Date Excavated: 12/3/2021
 Logged By: CSH
 Surface Elevation: Unknown

LOG OF BACKHOE TEST PIT

Project: Frog Pond West West
Wilsonville, Oregon

Project No. 21-2824

Test Pit No. **TP - 11**

Depth (ft)	Pocket Penetrometer (tons/ft ²)	Sample Interval	Sample Designation	Moisture Content (%)	Groundwater	Material Description
1						Moist, soft, dark brown, SILT (OL), heavy organics [Topsoil]
2						Moist, stiff, brown, clayey SILT (ML) with sand, orange and dark brown mottling. [Willamette Formation] Sandiness increasing with depth
3						
4						
5						
6						
7						Moist, stiff, brown, sandy SILT (ML), orange and dark brown mottling, slightly micaceous. [Willamette Formation]
8						
9						
10						
11						<i>Test Pit terminated at 10 feet</i> <i>No groundwater or seepage encountered</i> <i>No caving</i>
12						
13						
14						
15						
16						

HCSI **HARDMAN GEOTECHNICAL SERVICES INC.**
 Practical. Cost-Effective. Geotechnical Solutions
 10110 SW Nimbus Ave., Suite B-5
 Portland, OR 97223
 (503) 530-8076

LEGEND



S-#



Soil Sample Depth Interval and Designation

Water Level at Time of Excavation

Date Excavated: 12/3/2021
 Logged By: CSH
 Surface Elevation: Unknown

LOG OF HAND AUGER BORING

Project: Frog Pond West West
Wilsonville, Oregon

Project No. 21-2824

Boring No. **HA - 1**

Depth (ft)	Pocket Penetrometer (tons/ft ²)	Sample Interval	Sample Designation	Moisture Content (%)	Groundwater	Material Description
1						Moist, soft, dark brown, SILT (OL), heavy organics with grass and roots in the top 6 inches. [Topsoil]
2						Moist, medium stiff, brown and light grey, clayey SILT (ML), orange and dark brown mottling. [Willamette Formation]
3						
4						
5						Moist, stiff to very stiff, brown, sandy SILT (ML) with clay, orange and dark brown mottling, heavily micaceous. [Willamette Formation]
6						<i>Boring terminated at 5 feet No groundwater or seepage encountered No caving</i>
7						
8						
9						
10						

HCSI **HARDMAN GEOTECHNICAL SERVICES INC.**
 Practical. Cost-Effective. Geotechnical Solutions
 10110 SW Nimbus Ave., Suite B-5
 Portland, OR 97223
 (503) 530-8076

LEGEND



S-#



Soil Sample Depth Interval and Designation

Water Level at Time of Excavation

Date Bored: 12/9/2021

Logged By: CSH

Surface Elevation:

LOG OF HAND AUGER BORING

Project: Frog Pond West West
Wilsonville, Oregon

Project No. 21-2824

Boring No. **HA - 2**

Depth (ft)	Pocket Penetrometer (tons/ft ²)	Sample Interval	Sample Designation	Moisture Content (%)	Groundwater	Material Description
0						Moist, soft, dark brown, SILT (OL), heavy organics with grass and roots in the top 6 inches. [Topsoil]
1						Moist, medium stiff, brown and light grey, clayey SILT (ML), orange and dark brown mottling. [Willamette Formation]
2						
3						Moist, stiff to very stiff, brown, sandy SILT (ML), micaceous. [Willamette Formation]
4						
5						
6						
7						<i>Boring terminated at 6 feet No groundwater or seepage encountered No caving</i>
8						
9						
10						

HCSI HARDMAN
GEOTECHNICAL
SERVICES INC.
Practical. Cost-Effective Geotechnical Solutions
10110 SW Nimbus Ave., Suite B-5
Portland, OR 97223
(503) 530-8076

LEGEND



S-#



Soil Sample Depth
Interval and Designation

Water Level at
Time of Excavation

Date Bored: 12/9/2021

Logged By: CSH

Surface Elevation:

LOG OF HAND AUGER BORING

Project: Frog Pond West West
Wilsonville, Oregon

Project No. 21-2824

Boring No. **HA - 3**

Depth (ft)	Pocket Penetrometer (tons/ft ²)	Sample Interval	Sample Designation	Moisture Content (%)	Groundwater	Material Description
1						Moist, soft, dark brown, SILT (OL), heavy organics with grass and roots in the top 6 inches. [Topsoil]
2						Moist, soft, dark brown silt with organics and fractured rock. [Undocumented Fill]
3						
4						
5						Moist, stiff to very stiff, brown, sandy SILT (ML) [Willamette Formation]
6						<i>Boring terminated at 5 feet No groundwater or seepage encountered No caving</i>
7						
8						
9						
10						

HCSI HARDMAN
GEOTECHNICAL
SERVICES INC.
Practical. Cost-Effective Geotechnical Solutions
10110 SW Nimbus Ave., Suite B-5
Portland, OR 97223
(503) 530-8076

LEGEND



S-#



Soil Sample Depth
Interval and Designation

Water Level at
Time of Excavation

Date Bored: 12/9/2021

Logged By: CSH

Surface Elevation:

LOG OF HAND AUGER BORING

Project: Frog Pond West West
Wilsonville, Oregon

Project No. 21-2824

Boring No. **HA - 4**

Depth (ft)	Pocket Penetrometer (tons/ft ²)	Sample Interval	Sample Designation	Moisture Content (%)	Groundwater	Material Description
1						Moist, soft, dark brown, SILT (OL), heavy organics [Topsoil]
2						Moist, medium stiff, brown, clayey SILT (ML) with sand, orange and dark brown mottling. [Willamette Formation]
3						Dry, very stiff, light brown, sandy SILT (ML), orange and dark brown mottling. [Willamette Formation]
4						
5						
6						
7						<i>Test Pit terminated at 6 feet No groundwater or seepage encountered No caving</i>
8						
9						
10						

HCSI HARDMAN
GEOTECHNICAL
SERVICES INC.
Practical. Cost-Effective Geotechnical Solutions
10110 SW Nimbus Ave., Suite B-5
Portland, OR 97223
(503) 530-8076

LEGEND



S-#



Soil Sample Depth
Interval and Designation

Water Level at
Time of Excavation

Date Bored: 12/9/2021

Logged By: CSH

Surface Elevation:

LOG OF HAND AUGER BORING

Project: Frog Pond West West
Wilsonville, Oregon

Project No. 21-2824

Boring No. **HA - 5**

Depth (ft)	Pocket Penetrometer (tons/ft ²)	Sample Interval	Sample Designation	Moisture Content (%)	Groundwater	Material Description
1						Moist, soft, dark brown, SILT (OL), heavy organics [Topsoil]
2						Moist, medium stiff, brown, clayey SILT (ML) with sand, orange and dark brown mottling. [Willamette Formation]
3						
4						
5						
6						<i>Test Pit terminated at 5 feet No groundwater or seepage encountered No caving</i>
7						
8						
9						
10						

HCSI **HARDMAN GEOTECHNICAL SERVICES INC.**
 Practical. Cost-Effective. Geotechnical Solutions
 10110 SW Nimbus Ave., Suite B-5
 Portland, OR 97223
 (503) 530-8076

LEGEND



S-#



Soil Sample Depth Interval and Designation

Water Level at Time of Excavation

Date Bored: 12/9/2021

Logged By: CSH

Surface Elevation:

LOG OF HAND AUGER BORING

Project: Frog Pond West West
Wilsonville, Oregon

Project No. 21-2824

Boring No. **HA - 6**

Depth (ft)	Pocket Penetrometer (tons/ft ²)	Sample Interval	Sample Designation	Moisture Content (%)	Groundwater	Material Description
1						Slightly Moist, Medium Dense, Poorly Graded, Subangular, 1"-0" GRAVEL (GP) in Dark Brown Silty Matrix, Top 3" Highly Organic with Grass Roots <i>[Undocumented Fill]</i>
2						Boring refusal on gravel at 1.1 feet (13 inches) No groundwater or seepage encountered No caving
3						
4						
5						
6						
7						
8						
9						
10						

HCSI HARDMAN GEOTECHNICAL SERVICES INC.
 Practical. Cost-Effective. Geotechnical Solutions
 10110 SW Nimbus Ave., Suite B-5
 Portland, OR 97223
 (503) 530-8076

LEGEND



S-#



Soil Sample Depth Interval and Designation

Water Level at Time of Excavation

Date Bored: ~~10/09/2021~~ 10/09/2021

Logged By: CSH

Surface Elevation:



**HARDMAN
GEOTECHNICAL
SERVICES INC.**

Practical, Cost-Effective Geotechnical Solutions

INFILTRATION TEST DATA

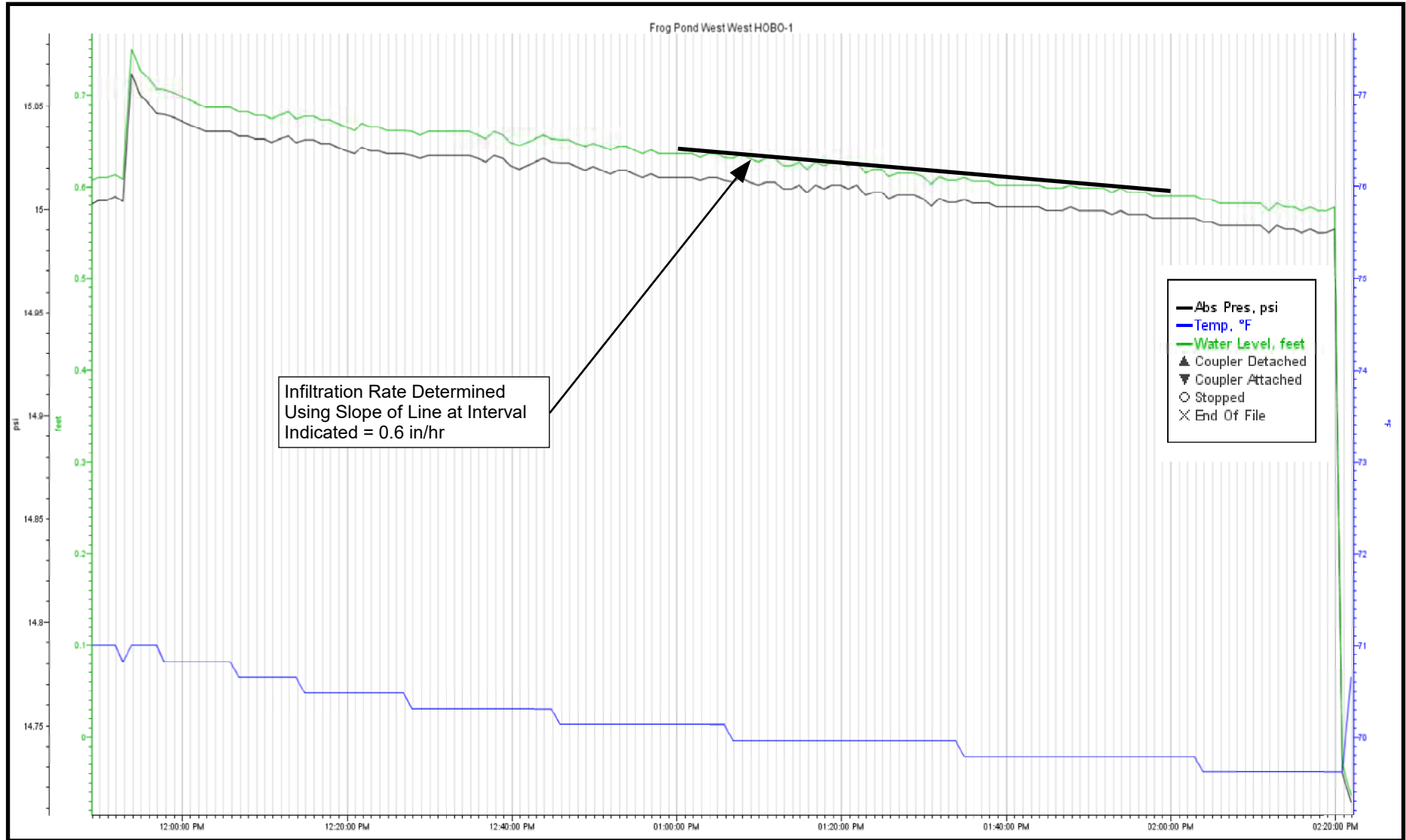

Project: Frog Pond West West
Wilsonville, Oregon

Date Tested: 12/7/2021
Tested By: CSH
Project No: 21-2824

Boring: HA-1
Depth: 5 Feet



**HARDMAN
GEOTECHNICAL
SERVICES INC.**

Practical, Cost-Effective Geotechnical Solutions

INFILTRATION TEST DATA

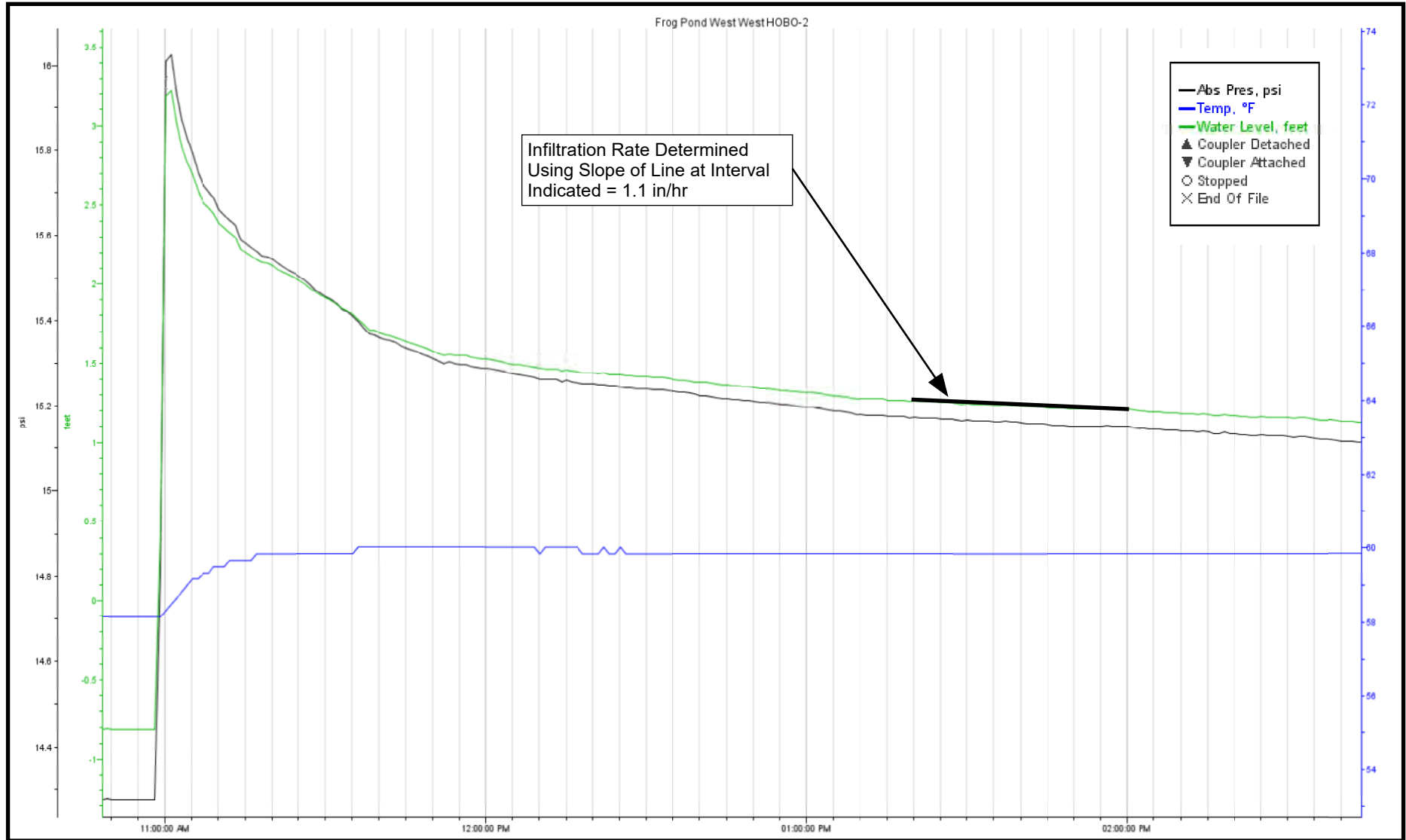

Project: Frog Pond West West
Wilsonville, Oregon

Date Tested: 12/7/2021
Tested By: CSH
Project No: 21-2824

Boring: HA-2
Depth: 6 Feet



**HARDMAN
GEOTECHNICAL
SERVICES INC.**

Practical, Cost-Effective Geotechnical Solutions

INFILTRATION TEST DATA

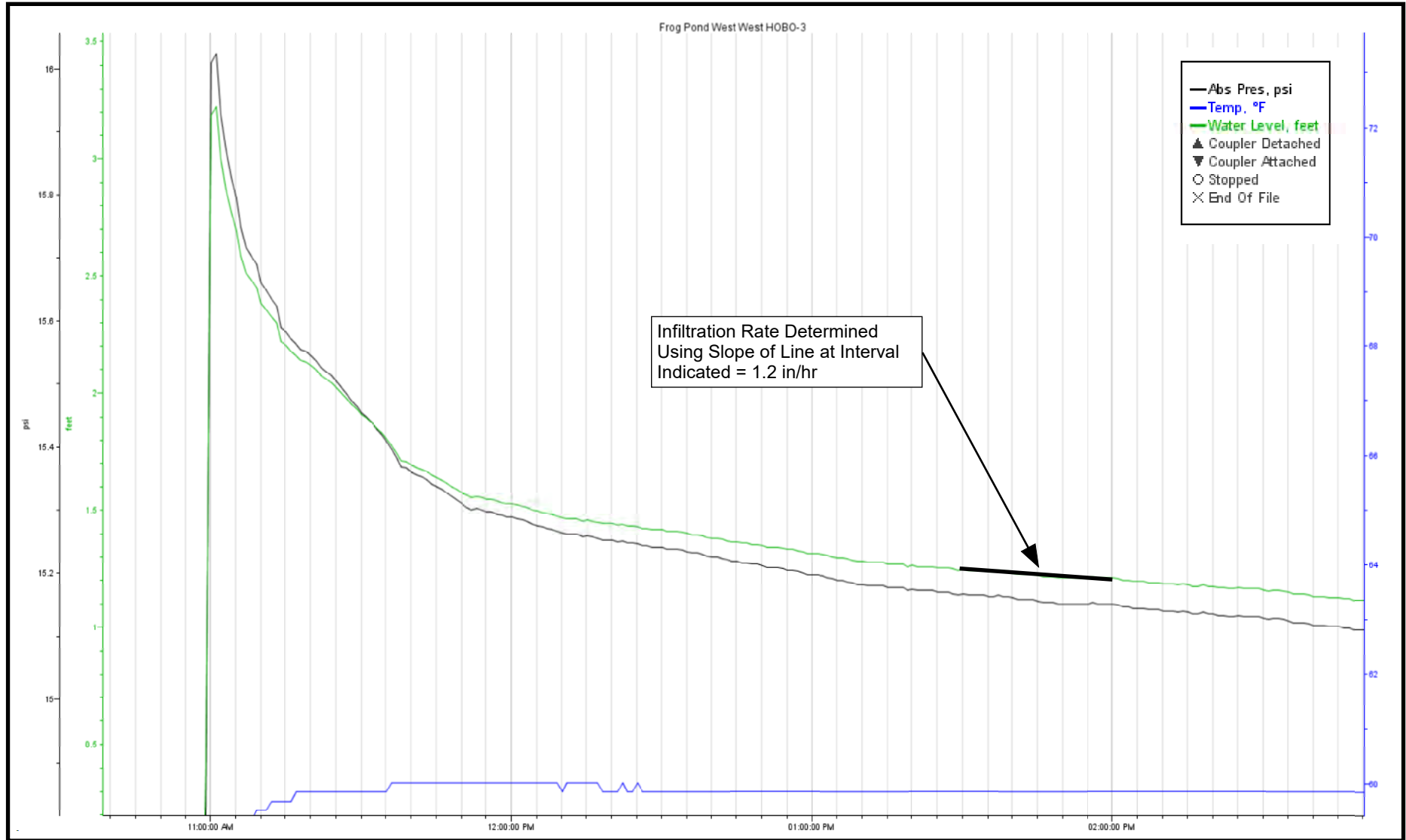

Project: Frog Pond West West
Wilsonville, Oregon

Date Tested: 12/7/2021
Tested By: CSH
Project No: 21-2824

Boring: HA-3
Depth: 6 Feet

ASCE 7 Hazards Report

Address:
No Address at This
Location

Standard: ASCE/SEI 7-16
Risk Category: II
Soil Class: D - Stiff Soil

Elevation: 216.52 ft (NAVD 88)
Latitude: 45.3218
Longitude: -122.754

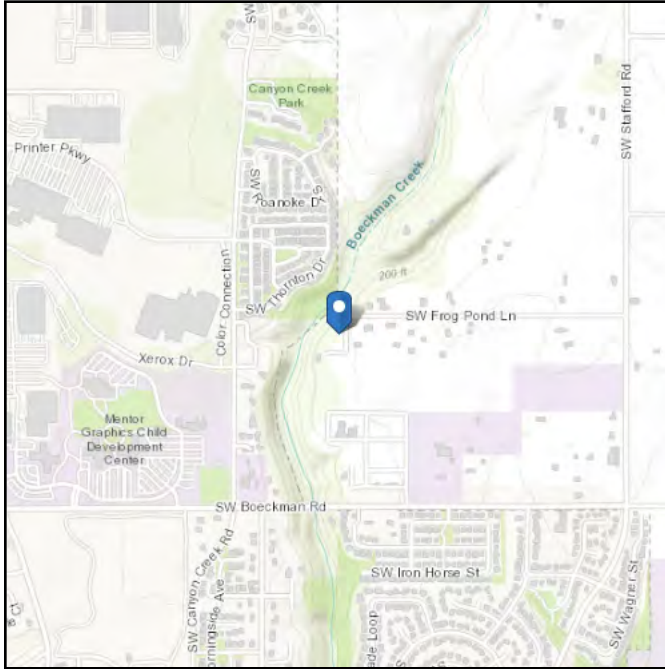

Site Soil Class: D - Stiff Soil

Results:

S_s :	0.82	S_{D1} :	N/A
S_1 :	0.381	T_L :	16
F_a :	1.172	PGA :	0.373
F_v :	N/A	PGA _M :	0.458
S_{MS} :	0.961	F_{PGA} :	1.227
S_{M1} :	N/A	I_e :	1
S_{DS} :	0.641	C_v :	1.21

Ground motion hazard analysis may be required. See ASCE/SEI 7-16 Section 11.4.8.

Data Accessed: Tue Dec 14 2021

Date Source: [USGS Seismic Design Maps](#)

The ASCE 7 Hazard Tool is provided for your convenience, for informational purposes only, and is provided “as is” and without warranties of any kind. The location data included herein has been obtained from information developed, produced, and maintained by third party providers; or has been extrapolated from maps incorporated in the ASCE 7 standard. While ASCE has made every effort to use data obtained from reliable sources or methodologies, ASCE does not make any representations or warranties as to the accuracy, completeness, reliability, currency, or quality of any data provided herein. Any third-party links provided by this Tool should not be construed as an endorsement, affiliation, relationship, or sponsorship of such third-party content by or from ASCE.

ASCE does not intend, nor should anyone interpret, the results provided by this Tool to replace the sound judgment of a competent professional, having knowledge and experience in the appropriate field(s) of practice, nor to substitute for the standard of care required of such professionals in interpreting and applying the contents of this Tool or the ASCE 7 standard.

In using this Tool, you expressly assume all risks associated with your use. Under no circumstances shall ASCE or its officers, directors, employees, members, affiliates, or agents be liable to you or any other person for any direct, indirect, special, incidental, or consequential damages arising from or related to your use of, or reliance on, the Tool or any information obtained therein. To the fullest extent permitted by law, you agree to release and hold harmless ASCE from any and all liability of any nature arising out of or resulting from any use of data provided by the ASCE 7 Hazard Tool.

Appendix C

DownStream Analysis





Memorandum

To: Keith Buisman, PE
From: Roger Tiffany, EI and Rose Horton, PE
Copies: File
Date: May 17, 2022
Subject: Downstream Impact Analysis of Boeckman Creek
Project No.: 20015

Introduction

Otak has conducted a downstream impact analysis on the downstream storm conveyance system for the proposed Frog Pond Terrace and Frog Pond Overlook developments, per City of Wilsonville 2015 standards. These proposed developments are located adjacent to Frog Pond Lane and east of Boeckman Creek, as shown on Figure 1.



Figure 1 Vicinity Map

The development will meet the City of Wilsonville Public Work Standards Section 301.4.04 which requires flow control from post-development conditions for peak flow rates generated by between 42% of the 2-year storm up to the 10-year storm.

To meet the requirements of City of Wilsonville Public Work Standards Section 301.5.01, a downstream analysis shall include:

- verifying that the downstream system has the capacity to convey the 25-year design storm.
- extending the analysis downstream to a point in the drainage system where the proposed development site contributes 10% or less of the total tributary drainage flow or for one-quarter mile downstream of the approved point of discharge.

Per email communications with Kerry Rappold on March 3, 2022, the downstream analysis should extend down to the flow control structure directly upstream of SW Boeckman Road.

Existing Conveyance System

The existing conveyance system used in this analysis is shown on Figure 2 (attached), which also includes the drainage basin delineation, time of concentration (T_c) flow paths, and runoff node locations represented in the hydraulic model. Cross sections of the open channel system were obtained from LiDAR and field observation. The proposed Frog Pond Terrace and Frog Pond Overlook developments will discharge runoff into the existing Boeckman Creek channel approximately 1,330 feet upstream of the existing flow control structure.

The stretch of channel downstream of the project site was visited on March 16, 2022. The purpose of the field visit was to observe and document existing channel conditions, outfalls, and contributing waterways. Visual documentation of the drainage system along the channel is included in the Photo Log in Appendix A.

Conveyance Hydrology

Peak runoff rates from the drainage basins delineated in Figure 2 during proposed conditions were calculated using XPSWMM V2021. The Santa Barbara Urban Hydrograph (SBUH) method was used to apply the conveyance design event (25-year recurrence interval, 24-hour duration, NRCS Type 1A rainfall distribution), per Section 301.5.01. Time of Concentration values were calculated for delineated drainage basin using TR-55 equations. Time of Concentration (T_c) flow paths are shown in Figure 2 and corresponding calculations for each drainage basin are included in Appendix B. A time of concentration of five minutes, the minimum allowable, was applied to steep and developed basins for a conservative estimate.

The study area is primarily comprised of Aloha silt loam categorized in the hydrologic soil groups (HSG) Type D and Woodburn silt loam categorized as HSG Type C. HSG D soils generally exhibit very slow infiltration rates when thoroughly wet. The steep area of the channel is Xerochrepts and Haploxerolls which is categorized as HSG Type B with moderate infiltration. A Curve Number (CN) of 98 was used for all impervious areas. The pervious areas were open space with good grass cover, thus a CN of 74 (HSG Type C) was used as applicable.

The basins downstream of the proposed project site are developed residential areas. Impervious percentages were estimated based on existing impervious surfaces captured in 2022 aerial imagery.

The upstream flow in Boeckman Creek was obtained from StreamStats (see Appendix B). It is not recommended to mix hydrologic methods and this data should not be used for design. In this case, the StreamStats data was used provide a rough order of magnitude flowrate for the large upstream basin in comparison with the flowrates generated from the proposed development. Table 1 summarizes the 25-year peak flowrates in Boeckman Creek for proposed project conditions calculated in XP-SWMM. The stationing represents the distance upstream from the existing Boeckman Road flow control structure. The existing flow control structure at the end of the analysis is 1,331 feet downstream from the project's proposed discharge location.

Table 1 Peak 25-Year Flowrates

Node	Station	Total Contributing Basin Area (ac)	Flow Rate (cfs)
Drainage Node 4	16+95	910	116.62
Drainage Node 3	13+31	978	158.38
Drainage Node 2	5+78	992	160.6
Drainage Node 1	2+00	1,025	173.6

Downstream Conveyance Modeling Analysis

The stormwater conveyance network was analyzed in XP-SWMM. The conveyance system was modeled to determine whether the existing downstream system has sufficient capacity to support the Frog Pond Overlook and Frog Pond Terrace developments runoff undetained during the 25-year, 24-hour storm event. The inverts are from as-builts of the flow control structure and LiDAR data. Manning's n values of 0.035 or 0.04 were applied to the channel of Boeckman Creek depending on the amount of wood located in the channel along the reach. A Manning's n value of 0.1 was applied to the overbanks. A minimum of one-foot of freeboard between the hydraulic grade line (HGL) and the top of bank was confirmed. The model does not include the effect of the existing flow control structure on the system. Appendix C includes output information from the XP-SWMM model, summarizing the channel network characteristics and results of the hydraulic routing during the design storm.

Conclusions

The downstream stormwater conveyance system was analyzed to confirm conveyance capacity for the proposed development to Boeckman Road. The system consists entirely of open channel upstream of the existing flow control structure at Boeckman Road. A site visit along the downstream reach provided a qualitative assessment of the storm conveyance system and found no evidence of capacity restrictions under existing conditions. The channel was modeled using XP-SWMM software and shows adequate capacity for the proposed flows and the existing flow control structure creates ponding in the downstream reach.

References

Wilsonville, 2015. *City of Wilsonville Public Works Standards. Section 3, Stormwater & Surface Water Design and Construction Standards*, City of Wilsonville, Revised December 2015.

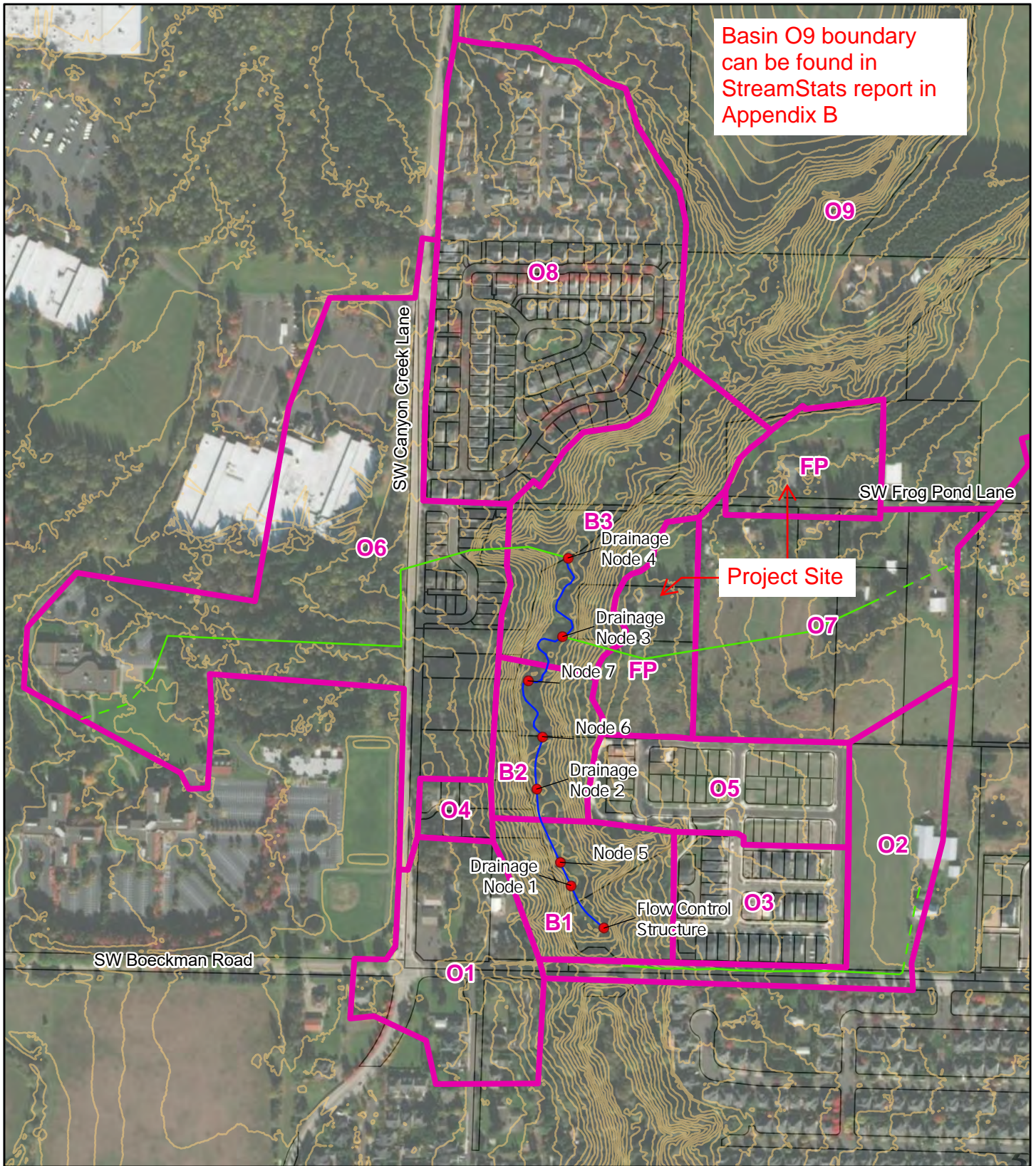
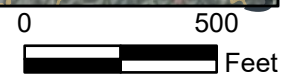

FIGURE 2
DOWNSTREAM ANALYSIS
BOECKMAN CREEK
WILSONVILLE, OREGON

Legend

- Nodes
- Stream Centerline (Analysis Extent)
- Drainage Basins
- Contours (5 ft)
- Time of Concentration Path
- Shallow Concentrated Flow
- - - Sheet Flow



Data Sources:
 Date: 4/18/2022
 Disclaimer: This data is not to survey accuracy and is meant for planning purposes only.
 L:\Project\2000\2015\CADD\GIS\MXD\2015-DSA Analysis\2015-DSA Analysis.aprx

Downstream Analysis of Boeckman Creek
Appendix A
Photo Log



Reach 1 - Flow Control Structure

Photo looking upstream



- Measured bank full depth – 52"
- Wide activated overbank floodplain
- Minimal wood and vegetation in channel

Reach 2

Photo looking upstream



- Measured bank full depth – 30"
- Activated overbank floodplain
- Higher density of wood in channel and beaver dams

Reach 3

Photo looking downstream



- Measured bank full depth – 48”
- More wood in channel than other reaches

Reach 4

Photo looking upstream



- Measured bank full depth – 32”
- More wood located in channel than other reaches

Reach 5

Photo looking downstream



- Measured bank full depth – 24"
- Scattered wood in channel

Reach 6 – Outfall General Location

Photo looking upstream



- Measured depth 2 ft
- Additional 14" above water surface to TOB at 1:1 slope
- Scattered wood in channel

Downstream Analysis of Boeckman Creek
Appendix B
Hydrology



DSA Drainage Basin Areas

Boeckman Creek

Basin	XP-SWMM Node	Pervious Curve #	Impervious Area		Total Area	
			Tc	%	(sf)	(ac)
Site Total				390	44,646,105	1,025
O1	1	74	5	30	440,423	10.11
O3	1	74	5	50	288,301	6.62
O5	2	74	5	60	335,041	7.69
O4	2	74	5	30	58,509	1.34
O6	4	74	55.4	50	1,520,186	34.90
O8	3	74	5	80	1,250,809	28.71
B1	1	74	5	0	292,661	6.72
B2	2	74	5	0	206,554	4.74
B3	3	74	5	0	542,471	12.45
O9*	4	74			38,128,714	875.31
O2	1	74	28.2	20	405,690	9.31
O7	3	74	48.4	10	759,013	17.42
FP	3	74	5	60	417,733	9.59

*Modeled flow rates from Stream Stats

StreamStats Report - Boeckman Creek

Region ID: OR

Workspace ID: OR20220117180346388000

Clicked Point (Latitude, Longitude): 45.32457, -122.75288

Time: 2022-01-17 10:04:08 -0800

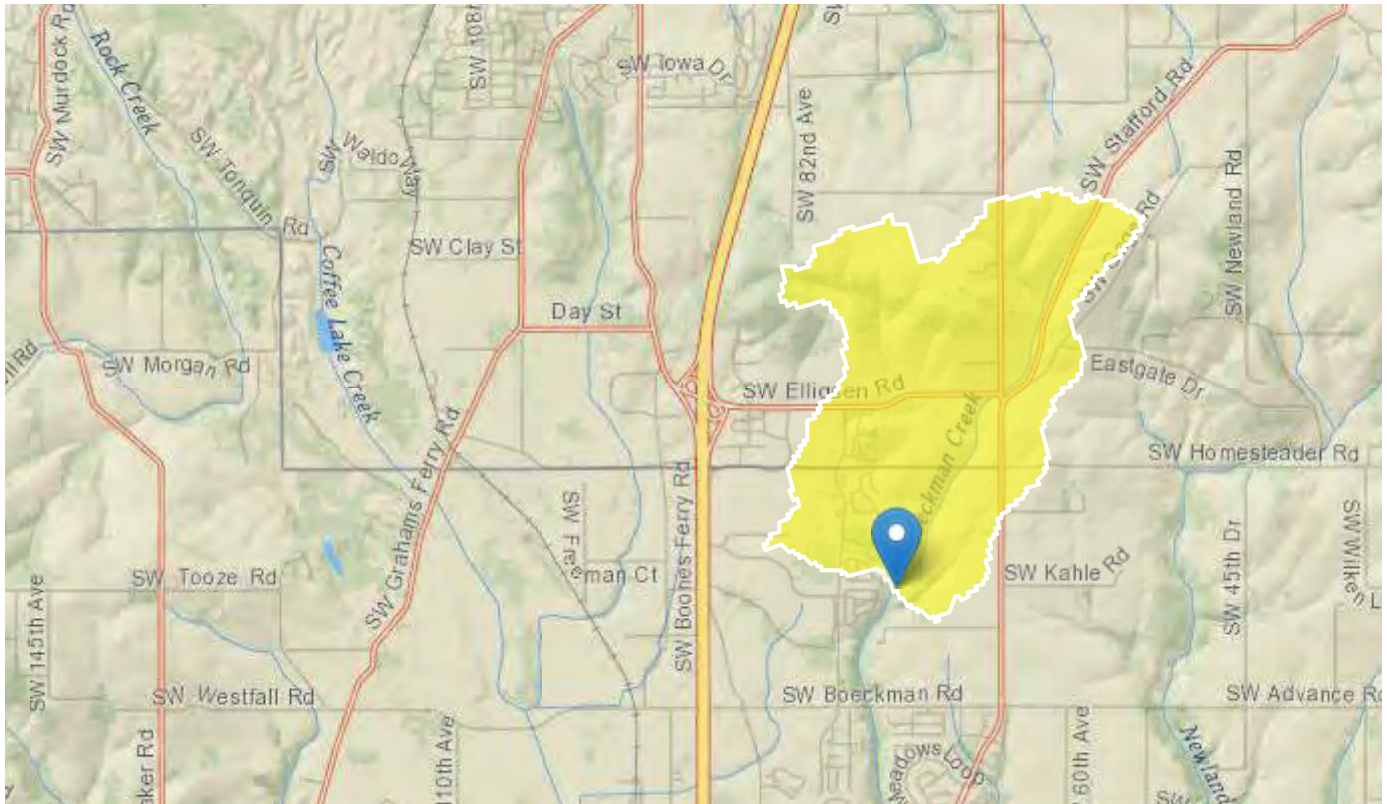

Basin Characteristics

Parameter Code	Parameter Description	Value	Unit
DRNAREA	Area that drains to a point on a stream	1.59	square miles
I24H2Y	Maximum 24-hour precipitation that occurs on average once in 2 years - Equivalent to precipitation intensity index	1.81	inches
SOILPERM	Average Soil Permeability	0.71	inches per hour
JANMAXT2K	Mean Maximum January Temperature from 2K resolution PRISM 1961-1990 data	46.2	degrees F

Parameter Code	Parameter Description	Value	Unit
WATCAPORC	Available water capacity from STATSGO data using methods from SIR 2005-5116	0.13	inches
ORREG2	Oregon Region Number	10001	dimensionless
BSLOPD	Mean basin slope measured in degrees	4.36	degrees
JANMINT2K	Mean Minimum January Temperature from 2K resolution PRISM PRISM 1961-1990 data	33.2	degrees F
ELEV	Mean Basin Elevation	338	feet
PRECIP	Mean Annual Precipitation	44.6	inches
DRNDENSITY	Basin drainage density defined as total stream length divided by drainage area.	0.63	dimensionless
MINBELEV	Minimum basin elevation	170	feet
MINTEMP	Mean annual minimum air temperature over basin surface area as defined in SIR 2008-5126	42.8	degrees F
JANMINTMP	Mean Minimum January Temperature	33.8	degrees F
MAXTEMP	Mean annual maximum air temperature over basin area from PRISM 1971-2000 800-m grid	62.4	degrees F
LC11DVOPN	Percentage of developed open area from NLCD 2011 class 21	13	percent
LC11WETLND	Percentage of wetlands, classes 90 and 95, from NLCD 2011	0	percent
LC11IMP	Average percentage of impervious area determined from NLCD 2011 impervious dataset	13.4	percent
STRMTOT	total length of all mapped streams (1:24,000-scale) in the basin	1.62	miles

Peak-Flow Statistics Parameters [Reg 2B Western Interior LT 3000 ft Cooper]

Parameter Code	Parameter Name	Value	Units	Min Limit	Max Limit
DRNAREA	Drainage Area	1.59	square miles	0.37	7270
BSLOPD	Mean Basin Slope degrees	4.36	degrees	5.62	28.3
I24H2Y	24 Hour 2 Year Precipitation	1.81	inches	1.53	4.48
ELEV	Mean Basin Elevation	338	feet		

Parameter Code	Parameter Name	Value	Units	Min Limit	Max Limit
ORREG2	Oregon Region Number	10001	dimensionless		

Peak-Flow Statistics Disclaimers [Reg 2B Western Interior LT 3000 ft Cooper]

One or more of the parameters is outside the suggested range. Estimates were extrapolated with unknown errors

Peak-Flow Statistics Flow Report [Reg 2B Western Interior LT 3000 ft Cooper]

Statistic	Value	Unit
50-percent AEP flood	45.8	ft ³ /s
20-percent AEP flood	68.7	ft ³ /s
10-percent AEP flood	84.7	ft ³ /s
4-percent AEP flood	105	ft ³ /s
2-percent AEP flood	121	ft ³ /s
1-percent AEP flood	137	ft ³ /s
0.2-percent AEP flood	174	ft ³ /s

Peak-Flow Statistics Citations

Cooper, R.M., 2005, Estimation of Peak Discharges for Rural, Unregulated Streams in Western Oregon: U.S. Geological Survey Scientific Investigations Report 2005-5116, 76 p. (<http://pubs.usgs.gov/sir/2005/5116/pdf/sir2005-5116.pdf>)

Monthly Flow Statistics Parameters [LowFlow Apr Region02 2008 5126]

Parameter Code	Parameter Name	Value	Units	Min Limit	Max Limit
DRNAREA	Drainage Area	1.59	square miles	3.068	2025.868
PRECIP	Mean Annual Precipitation	44.6	inches	42.7355	101.2128
SOILPERM	Average Soil Permeability	0.71	inches per hour	0.502	3.724

Monthly Flow Statistics Parameters [LowFlow Aug Region02 2008 5126]

Parameter Code	Parameter Name	Value	Units	Min Limit	Max Limit
DRNAREA	Drainage Area	1.59	square miles	3.068	2025.868
DRNDENSITY	Basin Drainage Density	0.63	dimensionless	0.118	0.876

Time of Concentration Calculations

Boeckman Creek Downstream Analysis

BASINS:		07	06	02
SHEET FLOW				
INPUT				
Surface Description (from Table 3-1)		Short Grass/Woods mix	Short Grass	Short Grass
Manning's Roughness Coefficient		0.25	0.4	0.15
Flow Length, L (<300 ft)	ft	300	300	300
2-Year, 24-Hour Rainfall, P ₂	in	2.5	2.5	2.5
Land Slope, s	ft/ft	0.016	0.027	0.025
OUTPUT				
Travel Time	hr	0.73	0.86	0.41
SHALLOW CONCENTRATED FLOW				
INPUT				
Surface Description (paved or unpaved)		Unpaved		Unpaved
Flow Length, L	ft	1200		900
Watercourse Slope, s	ft/ft	0.075		0.06
OUTPUT				
Average Velocity, V	ft/s	4.42		3.95
Travel Time	hr	0.08		0.06
CHANNEL FLOW				
INPUT				
Cross Sectional Flow Area, a	ft ²		1.23	
Wetted Perimeter, p _w	ft		3.93	
Channel Slope, s	ft/ft		0.03	
Manning's Roughness Coefficient			0.013	
Flow Length, L	ft		1925	
OUTPUT				
Average Velocity, V	ft/s		9.15	
Hydraulic Radius, r = a/p _w	ft		0.31	
Travel Time	hr		0.058	
Basin Time of Concentration, T_c				
	hrs	0.81	0.92	0.47
	min	48.4	55.4	28.2

Downstream Analysis of Boeckman Creek
Appendix C
Model Results



XP-SWMM Layout

Boeckman Creek Downstream Analysis

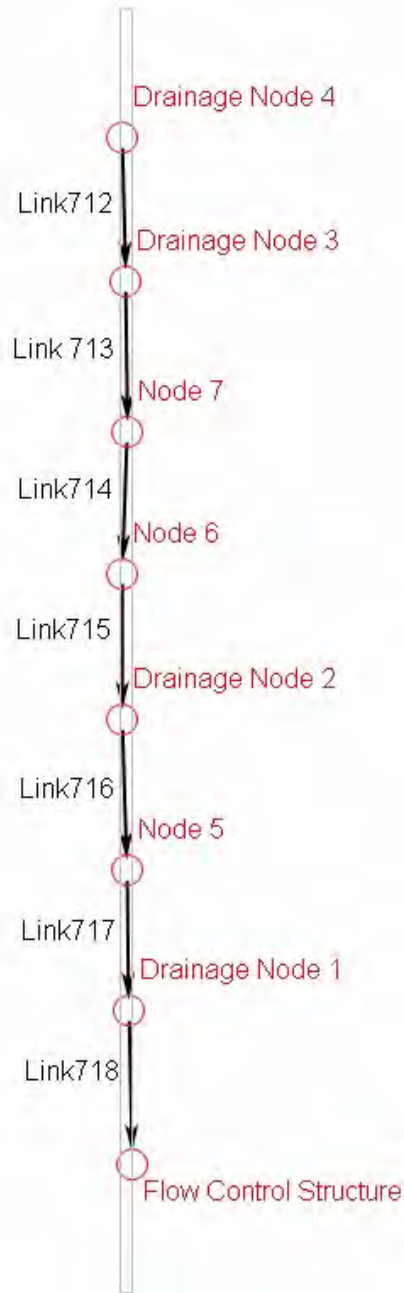

XP-SWMM RUNOFF DATA
Boeckman Creek Downstream Analysis
Proposed Conditions

SCS Type IA 25-Year Storm Event							
XP-SWMM Input Data					XP-SWMM Output Data		
Node Name	Total Area (ac)	Impervious %	Pervious Curve Number	Tc (min)	Rainfall Depth (in)	Unit Hydrograph Method	Surface Runoff Flow (cfs)
Drainage Node 1	10.11	30	74	5	3.9	Santa Barbara	6.24
Drainage Node 1	6.62	50	74	5	3.9	Santa Barbara	5.19
Drainage Node 1	6.72	0	74	5	3.9	Santa Barbara	2.65
Drainage Node 1	9.31	20	74	28.2	3.9	Santa Barbara	2.78
Drainage Node 2	7.69	60	74	5	3.9	Santa Barbara	6.70
Drainage Node 2	1.34	30	74	5	3.9	Santa Barbara	0.83
Drainage Node 2	4.74	0	74	5	3.9	Santa Barbara	1.87
Drainage Node 3	28.71	80	74	5	3.9	Santa Barbara	29.94
Drainage Node 3	12.45	0	74	5	3.9	Santa Barbara	4.91
Drainage Node 3	17.42	10	74	48.4	3.9	Santa Barbara	3.43
Drainage Node 3	9.59	60	74	5	3.9	Santa Barbara	8.36
Drainage Node 4	34.90	50	74	55.4	3.9	Santa Barbara	11.55

XP-SWMM HYDRAULICS DATA
Boeckman Creek Downstream Analysis
Proposed Conditions

SCS Type IA 25-Year Storm Event

Link Name	Location		Channel		Channel Profile								Channel Results			
	Node Limits		Length ft	Slope %	Ground Elevation (ft)		Invert Elevation (ft)		Max. Water Elevation (ft)		Freeboard (ft)		Max. Flow (cfs)	Max. Velocity (ft/s)	Max. Depth (ft)	y/d0
	From	To			US	DS	US	DS	US	DS	US	DS				
Link712	Drainage Node 4	Drainage Node 3	364.00	0.6	188.19	186.12	143.27	141.20	146.53	144.90	41.66	41.22	116.62	3.66	3.70	0.08
Link 713	Drainage Node 3	Node 7	309.00	0.6	186.12	184.93	141.20	139.42	144.90	143.17	41.22	41.76	158.38	3.74	3.75	0.08
Link715	Node 6	Drainage Node 2	196.00	0.2	186.41	186.00	137.41	137.00	142.07	141.44	44.34	44.56	153.78	3.20	4.66	0.10
Link717	Node 5	Drainage Node 1	93.00	1.0	185.60	184.43	136.60	135.10	139.77	137.15	45.83	47.28	160.56	4.60	3.17	0.07
Link714	Node 7	Node 6	248.00	0.8	184.93	186.41	139.42	137.41	143.17	142.07	41.76	44.34	155.45	2.99	4.66	0.10
Link716	Drainage Node 2	Node 5	285.00	0.1	186.00	185.60	137.00	136.60	141.44	139.77	44.56	45.83	160.61	3.75	4.44	0.09
Link718	Drainage Node 1	Flow Control Structure	200.00	1.6	184.43	181.33	135.10	132.00	137.15	133.96	47.28	47.37	173.66	7.02	2.05	0.04

Boeckman Road surface is higher than elevation 176

Cross Section for Link 713 is directly downstream of the proposed development

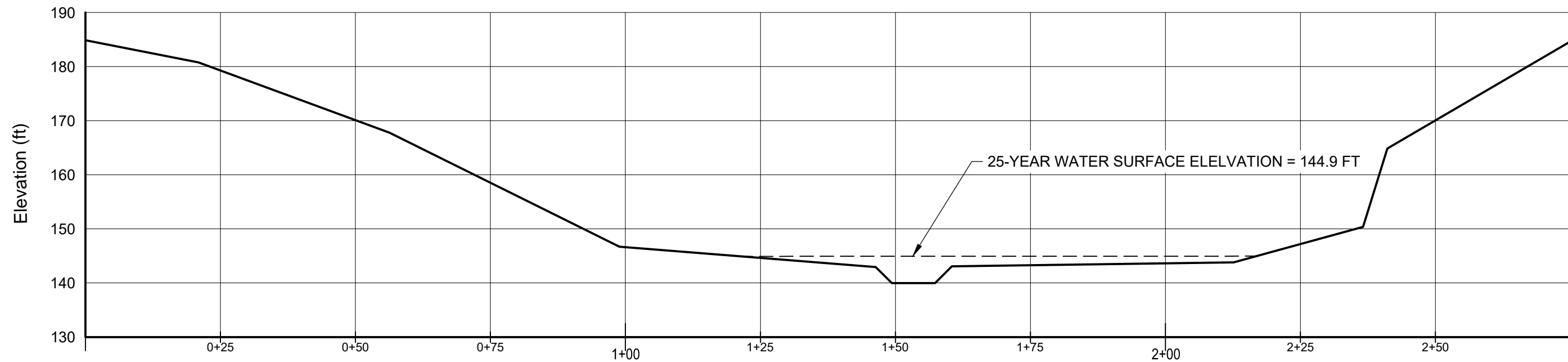

Link 713 Cross Section

Appendix D

BMP Sizing Tool Output

WES BMP Sizing Report

Project Information

Project Name	Frog Pond Terrace & Frog Pond Overlook
Project Type	Subdivision
Location	7480 SW Frog Pond Lane
Stormwater Management Area	6500
Project Applicant	West Hills Development
Jurisdiction	OutofDistrict

Drainage Management Area

Name	Area (sq-ft)	Pre-Project Cover	Post-Project Cover	DMA Soil Type	BMP
O3 Perv	1,235	Grass	LandscapeCsoil	C	Swale 4
O3 Imp.	11,474	Grass	ConventionalCo ncrete	C	Swale 4
T13 Perv.	1,602	Grass	LandscapeCsoil	C	Swale 3
T13 Imp.	4,670	Grass	ConventionalCo ncrete	C	Swale 3
T11 Imp.	9,707	Grass	ConventionalCo ncrete	C	Swale 1
T11 Perv.	548	Grass	LandscapeCsoil	C	Swale 1
Pond Basins Imp.	135,839	Grass	ConventionalCo ncrete	C	Pond
Pond Basins Perv.	121,992	Grass	LandscapeCsoil	C	Pond
T12 Imp.	2,693	Grass	ConventionalCo ncrete	C	Swale 2
T12 Perv.	889	Grass	LandscapeCsoil	C	Swale 2
O4 Imp.	11,624	Grass	ConventionalCo ncrete	C	Swale 5
O4 Perv.	1,180	Grass	LandscapeCsoil	C	Swale 5
FP2 Imp.	2,168	Grass	ConventionalCo ncrete	C	Swale 6
FP2 Perv.	183	Grass	LandscapeCsoil	C	Swale 6
FP3 Imp	3,657	Grass	ConventionalCo ncrete	C	Swale 6
T15 Perv	170	Grass	LandscapeCsoil	C	Swale 8

T15 Imp	3,005	Grass	ConventionalConcrete	C	Swale 8
T3 Perv	851	Grass	LandscapeCsoil	C	Swale 9
T3 Imp	5,035	Grass	ConventionalConcrete	C	Swale 9

LID Facility Sizing Details

LID ID	Design Criteria	BMP Type	Facility Soil Type	Minimum Area (sq-ft)	Planned Areas (sq-ft)	Orifice Diameter (in)
Swale 2	FlowControlAndTreatment	Vegetated Swale - Filtration	C2	156.9	336.0	0.6
Swale 1	WaterQuality	Vegetated Swale - Filtration	C2	149.7	294.0	0.6
Swale 3	FlowControlAndTreatment	Vegetated Swale - Filtration	C2	273.6	336.0	0.8
Swale 4	WaterQuality	Vegetated Swale - Filtration	C2	181.4	221.0	0.6
Swale 5	WaterQuality	Vegetated Swale - Filtration	C2	183.2	208.0	0.6
Swale 6	WaterQuality	Vegetated Swale - Filtration	C2	88.7	183.0	0.4
Swale 8	WaterQuality	Vegetated Swale - Filtration	C2	46.4	128.0	0.3
Swale 9	WaterQuality	Vegetated Swale - Filtration	C2	81.9	124.0	0.4

Pond Sizing Details

Pond ID	Design Criteria(1)	Facility Soil Type	Max Depth (ft)(2)	Top Area (sq-ft)	Side Slope (1:H)	Facility Vol. (cu-ft)(3)	Water Storage Vol. (cu-ft)(4)	Adequate Size?
Pond	FCWQT	Lined	5.00	7,523.0	3	26,105.1	18,278.3	Yes

1. FCWQT = Flow control and water quality treatment, WQT = Water quality treatment only

2. Depth is measured from the bottom of the facility and includes the three feet of media (drain rock, separation layer and growing media).

3. Maximum volume of the facility. Includes the volume occupied by the media at the bottom of the facility.

4. Maximum water storage volume of the facility. Includes water storage in the three feet of soil media assuming a 40 percent porosity.

Simple Pond Geometry Configuration

Pond ID: Pond

Design: FlowControlAndTreatment

Shape Curve

Depth (ft)	Area (sq ft)
5.0	7,523.0

Outlet Structure Details

Lower Orifice Invert (ft)	0.0
Lower Orifice Dia (in)	3.3
Upper Orifice Invert(ft)	3.4
Upper Orifice Dia (in)	8.3
Overflow Weir Invert(ft)	4.0
Overflow Weir Length (ft)	6.3

Flow Frequency Chart

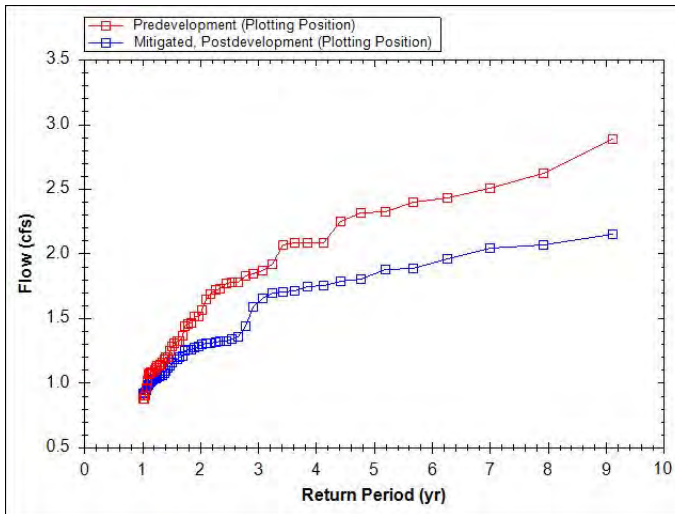

Flow Duration Chart

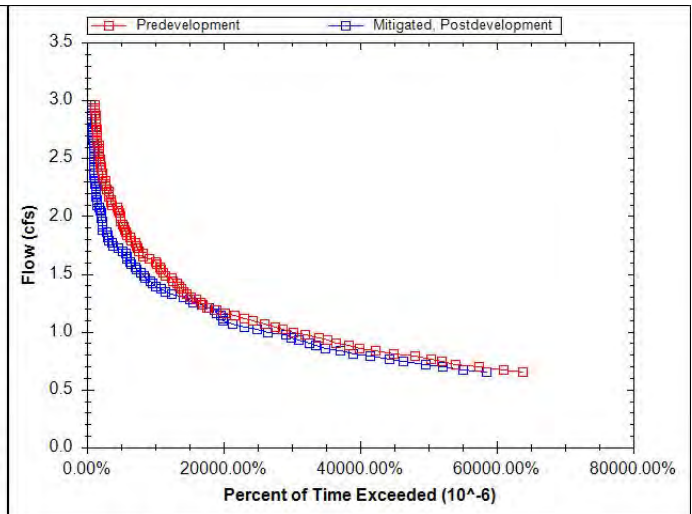

Appendix E
Operations and Maintenance Plans



This Detail Drawing may not be altered or changed in any manner except by the City Engineer. It is the responsibility of the user to acquire the most current version.

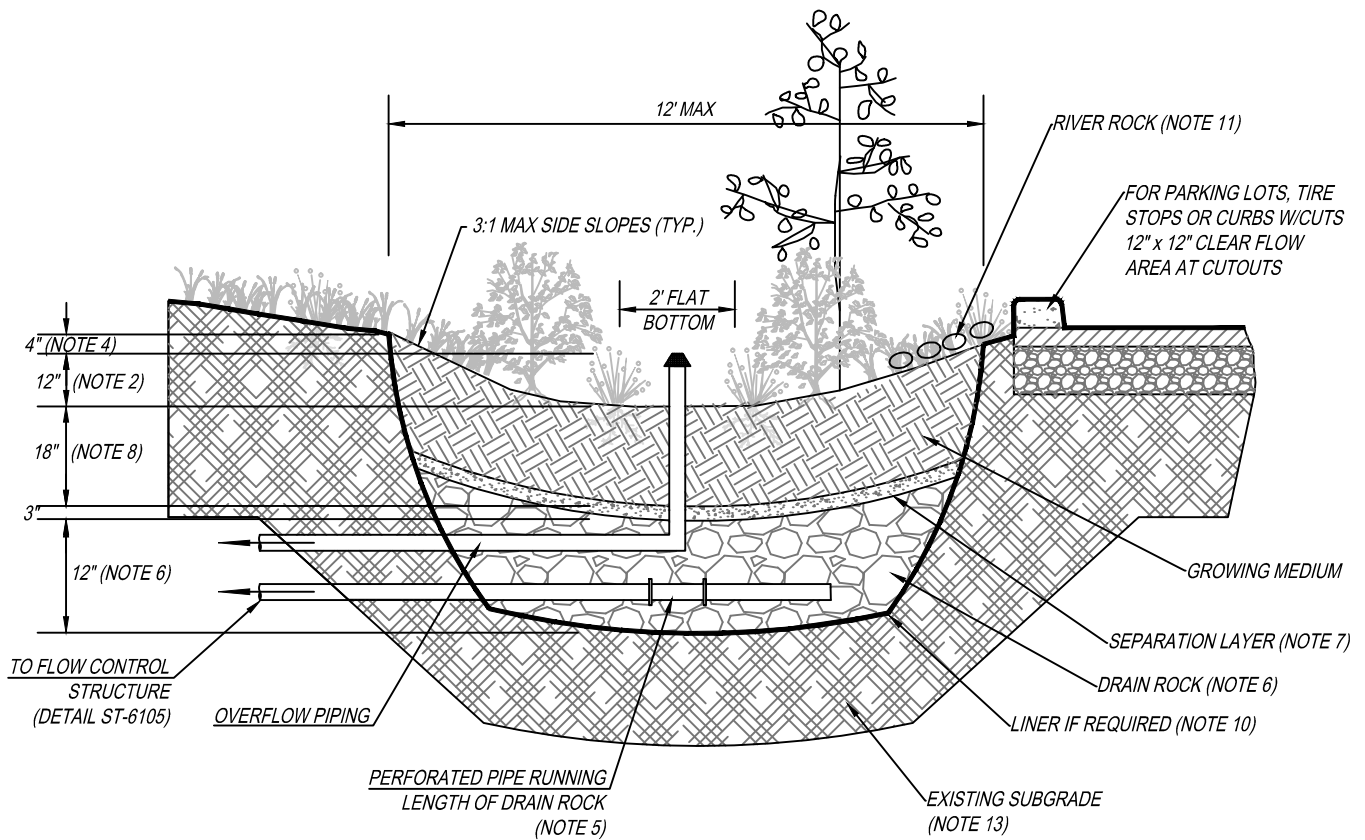

GENERAL NOTES:

1. **PROVIDE PROTECTION** FROM ALL VEHICLE TRAFFIC, EQUIPMENT STAGING, AND FOOT TRAFFIC IN PROPOSED INFILTRATION AREAS PRIOR TO, DURING AND AFTER CONSTRUCTION. UNLESS REQUIRED BY SITE CONDITIONS, UNLINED SWALES ARE PREFERRED TO ALLOW MAXIMUM INFILTRATION.
2. **DIMENSIONS:**
 - DEPTH OF SWALE (FROM TOP OF GROWING MEDIUM TO OVERFLOW ELEVATION); 12"
 - LONGITUDINAL SLOPE OF SWALE: 6.0% OR LESS
 - FLAT BOTTOM WIDTH: 2' MINIMUM
 - SIDE SLOPES OF SWALE: 3:1 MAXIMUM
3. **LOCATION/SETBACKS:**
 - FILTRATION SWALES SHALL BE 10' FROM FOUNDATIONS AND 5' FROM PROPERTY LINES UNLESS APPROVED BY BUILDING OFFICIAL
4. **OVERFLOW:**
 - INLET ELEVATION SHALL ALLOW FOR 4" OF FREEBOARD, MINIMUM.
 - PROTECT FROM DEBRIS AND SEDIMENT WITH STRAINER OR GRATE.
5. **PIPING:**
 - PERFORATED UNDER-DRAIN PIPING: SHALL BE ABS SCH. 40, CAST IRON, OR PVC SCH.40. MINIMUM DIAMETER IS 6". PIPING SHALL HAVE 1% GRADE AND FOLLOW THE UNIFORM PLUMBING CODE. PVC NOT ALLOWED ABOVE GROUND. WRAP UNDER-DRAIN IN FILTER FABRIC TO REDUCE TRANSPORT OF FINES.
 - OVERFLOW PIPING: SHALL BE ABS SCH. 40, CAST IRON, OR PVC SCH. 40 AND SHALL NOT BE PERFORATED. MINIMUM DIAMETER IS 6". PIPING SHALL HAVE 1% GRADE AND FOLLOW THE UNIFORM PLUMBING CODE. PVC NOT ALLOWED ABOVE GROUND.
6. **DRAIN ROCK:**
 - SIZE: 1 1/2" - 3/4" WASHED
 - DEPTH: 12"
7. **SEPARATION** BETWEEN DRAIN ROCK AND GROWING MEDIUM: SHALL BE A 3" LAYER OF 3/4" - 1/4" OPEN GRADED AGGREGATE.
8. **GROWING MEDIUM:**
 - 18" MINIMUM
 - SEE APPENDIX C FOR SPECIFICATION OR USE SAND/LOAM/COMPOST 3-WAY MIX.
 - FACILITY SURFACE AREA MAY BE REDUCED BY 25% WHEN GROWING MEDIA DEPTH IS INCREASED TO 30" OR MORE.
9. **VEGETATION:** FOLLOW LANDSCAPE PLANS OR REFER TO PLANTING REQUIREMENTS IN APPENDIX A.
10. **WATERPROOF LINER (IF REQUIRED):** SHALL BE 30 MIL PVC OR EQUIVALENT.
11. **INSTALL RIVER ROCK** SPLASH PAD OVER A NON WOVEN GEO TEXTILE FABRIC TO TRANSITION FROM INLETS TO GROWING MEDIUM. SIZE OF ROCK SHALL BE 1" TO 3", 4 SQUARE FEET, 6" DEEP.
12. **CHECK DAMS:** SHALL BE PLACED ACCORDING TO FACILITY DESIGN. REFER TO DETAIL ST-6100 FOR PROFILE AND SPACING.
13. **SEASONAL HIGH GROUNDWATER SEPARATION:**
 - SEPARATION DISTANCE AS REQUIRED BY CITY.

Vegetated Swale - Filtration

DRAWING NUMBER: ST-6045

DRAWN BY: SR

SCALE: N.T.S.

FILE NAME: ST-6045.DWG

APPROVED BY: NK

DATE: 6/3/16

CITY OF WILSONVILLE



PUBLIC WORKS STANDARDS

Vegetated Swales Operations & Maintenance Plan

What to Look For	What to Do
Structural Components, including inlets and outlets/overflows, shall freely convey stormwater.	
Clogged inlets or outlets	-Remove sediment and debris from catch basins, trench drains, curb inlets and pipes to maintain at least 50% conveyance capacity at all times.
Cracked Drain Pipes	-Replace/seal cracks. Replace when repair is insufficient.
Check Dams	-Maintain 4 - 10 inch deep rock check dams at design intervals.
Vegetation	
Dead or strained vegetation	-Replant per original planting plan, or substitute from Appendix A. -Irrigate as needed. Mulch banks annually. DO NOT apply fertilizers, herbicides, or pesticides.
Tall Grass and Vegetation	-Cut back to 4-6 inches, 1-2 times per year. Remove cuttings
Weeds	-Manually remove weeds. Remove all plant debris.
Growing/Filter Medium, including soil and gravels, shall sustain healthy plant cover and infiltrate within 72 hours.	
Gullies	-Fill, lightly compact, and plant vegetation to disperse flow.
Erosion	-Restore or create outfalls, checkdams, or splash blocks where necessary.
Slope Sippage	-Stabilize Slope.
Ponding	-Rake, till, or amend to restore infiltration rate.

Annual Maintenance Schedule:

Summer. Make any structural repairs. Improve filter medium as needed. Clear drain. Irrigate as needed.

Fall. Replant exposed soil and replace dead plants. Remove sediment and plant debris.

Winter. Monitor infiltration/flow-through rates. Clear inlets and outlets/overflows to maintain conveyance.

Spring. Remove sediment and plant debris. Replant exposed soil and replace dead plants. Mulch.

All seasons. Weed as necessary.

Maintenance Records: Record date, description, and contractor (if applicable) for all structural repairs, landscape maintenance, and facility cleanout activities. Keep work orders and invoices on file and make available upon request of the inspector.

Access: Maintain ingress/egress to design standards.

Infiltration/Flow Control: All facilities shall drain within 72 hours. Record time/date, weather, and site conditions when ponding occurs.

Pollution Prevention: All sites shall implement best management practices to prevent hazardous or solid wastes or excessive oil and sediment from contaminating stormwater. Contact _____ for immediate assistance responding to spills. Record time/date, weather, and site conditions if site activities contaminate stormwater.

Vectors (Mosquitoes & Rodents): Stormwater facilities shall not harbor mosquito larvae or rats that pose a threat to public health or that undermine the facility structure. Monitor standing water for small wiggling sticks perpendicular to the water's surface.

Note holes/burrows in and around facilities. Call Clackamas County Vector Control for immediate assistance to eradicate vectors. Record time/date, weather, and site conditions when vector activity observed.

Vegetated Swale O & M Plan

DRAWING NUMBER: ST-6055

DRAWN BY: SR

SCALE: N.T.S.

FILE NAME: ST-6055.DWG

APPROVED BY: NK

DATE: 10/8/14

CITY OF
WILSONVILLE



PUBLIC WORKS STANDARDS

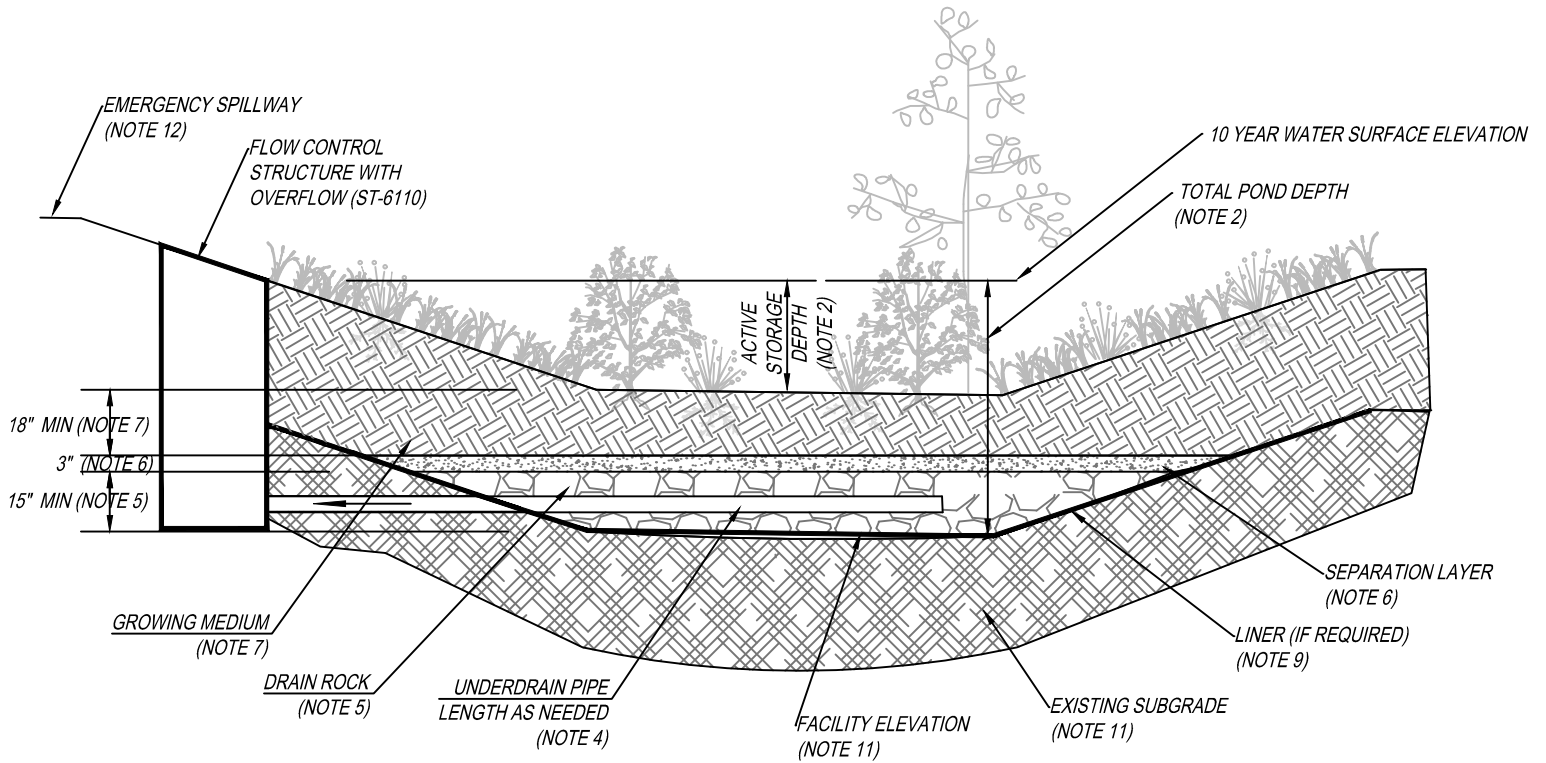

GENERAL NOTES:

1. **PROVIDE PROTECTION** FROM ALL VEHICLE TRAFFIC, EQUIPMENT STAGING, AND FOOT TRAFFIC IN PROPOSED INFILTRATION AREAS PRIOR TO, DURING AND AFTER CONSTRUCTION. UNLESS REQUIRED BY SITE CONDITIONS, UNLINED PONDS ARE PREFERRED TO ALLOW MAXIMUM INFILTRATION.
2. **DIMENSIONS:**
 - ACTIVE STORAGE DEPTH: (FROM TOP OF GROWING MEDIUM TO OVERFLOW ELEVATION); PER FACILITY SIZING MODEL
 - TOTAL POND DEPTH: 4' MINIMUM, PER FACILITY SIZING MODEL
 - BOTTOM SLOPE: 2.0% OR LESS
 - SIDE SLOPES OF DETENTION POND: 3:1 MAXIMUM
3. **LOCATION/SETBACKS:**
 - DETENTION POND SHALL BE 10' FROM FOUNDATIONS AND 5' FROM PROPERTY LINES UNLESS APPROVED BY BUILDING OFFICIAL.
4. **PIPING:**
 - PERFORATED UNDER-DRAIN PIPING: SHALL BE ABS SCH. 40, CAST IRON OR PVC SCH. 40. 6" MINIMUM DIAMETER. PIPING SHALL HAVE 1% GRADE AND FOLLOW THE UNIFORM PLUMBING CODE. PVC NOT ALLOWED ABOVE GROUND. WRAP UNDER-DRAIN PIPE IN FILTER FABRIC TO REDUCE TRANSPORT OF FINES.
 - OVERFLOW PIPING: SHALL BE ABS SCH. 40, CAST IRON OR PVC SCH. 40 AND SHALL NOT BE PERFORATED. MINIMUM DIAMETER IS 6". PIPING SHALL HAVE 1% GRADE AND FOLLOW THE UNIFORM PLUMBING CODE. PVC NOT ALLOWED ABOVE GROUND.
5. **DRAIN ROCK:**
 - SIZE: 1 1/2" - 3/4"-0 WASHED
 - DEPTH: 15" MINIMUM
6. **SEPARATION** BETWEEN DRAIN ROCK AND GROWING MEDIUM: SHALL BE A 3" LAYER OF 3/4" - 1/4" OPEN GRADED AGGREGATE.
7. **GROWING MEDIUM:**
 - 18" MINIMUM
 - SEE APPENDIX C FOR SPECIFICATION OR USE SAND/LOAM/COMPOST 3-WAY MIX.
8. **VEGETATION:** FOLLOW LANDSCAPE PLANS OR REFER TO PLANTING REQUIREMENTS IN APPENDIX A.
9. **WATERPROOF LINER (IF REQUIRED):** SHALL BE 30 MIL PVC OR EQUIVALENT FOR DETENTION POND.
10. **INSTALL RIVER ROCK** SPLASH PAD OVER A NON WOVEN GEO TEXTILE FABRIC TO TRANSITION FROM INLETS TO GROWING MEDIUM. SIZE OF ROCK SHALL BE 1" TO 3", 4 SQUARE FEET 6" DEEP.
11. **SEASONAL HIGH GROUNDWATER SEPARATION:**
 - SEPARATION DISTANCE AS REQUIRED BY CITY.
12. **EMERGENCY SPILLWAY** SIZED TO CONVEY THE 100 YEAR DESIGN STORM (S-2275). SEE PUBLIC WORKS STANDARDS 301.4.09

Detention Pond

DRAWING NUMBER: ST-6060

DRAWN BY: SR

SCALE: N.T.S.

FILE NAME: ST-6060.DWG

APPROVED BY: NK

DATE: 6/3/16

**CITY OF
WILSONVILLE**



PUBLIC WORKS STANDARDS

Detention Pond Operations & Maintenance Plan

Detention Pond removes pollutants through several processes: sedimentation, filtration, and biological processes. The facility owner must keep a log, recording all inspection dates, observations, and maintenance activities. The following items shall be inspected and maintained as stated:

What to Look For	What to Do
Structural Components, including inlets and outlets/overflows, shall freely convey stormwater.	
Clogged inlets or outlets	-Remove sediment and debris from catch basins, trench drains, curb inlets and pipes to maintain at least 50% conveyance capacity at all times.
Cracked Drain Pipes	-Repair/seal cracks. Replace when repair is insufficient.
Check Dams	-Maintain 4 - 10 inch deep rock check dams at design intervals.
Vegetation shall cover 90% of the facility.	
Dead or strained vegetation	-Replant per original planting plan, or substitute from Appendix A. -Irrigate as needed. Mulch banks annually. DO NOT apply fertilizers, herbicides, or pesticides.
Tall Grass and Vegetation	-Cut back grass and prune overgrowth 1-2 times per year. Remove cuttings.
Weeds	-Manually remove weeds. Remove all plant debris.
Growing/Filter Medium, including soil and gravels, shall sustain healthy plant cover and infiltrate within 72 hours.	
Gullies	-Fill, lightly compact, and plant vegetation to disperse flow.
Erosion	-Replace splash blocks or inlet gravel/rock.
Slope Sippage	-Stabilize 3:1 Slopes/banks with plantings from Appendix A
Ponding	-Rake, till, or amend to restore infiltration rate.

Annual Maintenance Schedule:

All facility components, vegetation, and source controls shall be inspected for proper operations and structural stability. These inspections shall occur, at a minimum, quarterly for the first 2 years from the date of installation, and 2 times per year thereafter, and within 48 hours after each major storm event.

Access: Maintain ingress/egress to design standards.

Infiltration/Flow Control: All facilities shall drain within 72 hours. Record time/date, weather, and site conditions when ponding occurs.

Pollution Prevention: All sites shall implement best management practices to prevent hazardous or solid wastes or excessive oil and sediment from contaminating stormwater. Contact _____ for immediate assistance responding to spills. Record time/date, weather, and site conditions if site activities contaminate stormwater.

Vectors (Mosquitoes & Rodents): Stormwater facilities shall not harbor mosquito larvae or rats that pose a threat to public health or that undermine the facility structure. Monitor standing water for small wiggling sticks perpendicular to the water's surface. Note holes/burrows in and around facilities. Call Clackamas County Vector Control for immediate assistance to eradicate vectors. Record time/date, weather, and site conditions when vector activity observed.

Detention Pond O & M Plan

DRAWING NUMBER: ST-6065

DRAWN BY: SR

SCALE: N.T.S.

FILE NAME: ST-6065.DWG

APPROVED BY: NK

DATE: 10/8/14

CITY OF
WILSONVILLE



PUBLIC WORKS STANDARDS

STORMWATER FACILITIES OPERATIONS AND MAINTENANCE CHECKLIST

Problem	Frequency	Trigger	Preferred Condition
<i>Sediment Accumulation in Treatment Area</i>	<i>Monthly from November through April Annually Required</i>	<i>Sediment depth exceeds 3 inches</i>	<i>Sediment removed from vegetated treatment area: level side to side and drains freely toward outlet; no standing water within 24 hours of any major storm (1" in 24 hours)</i>
<i>Erosion Scouring</i>	<i>Monthly from November through April Annually Required</i>	<i>Monthly from November through April Annually Required</i>	<i>Repair ruts or bare areas by filling with topsoil during dry season; regrade and replant large bare areas.</i>
<i>Standing Water</i>	<i>Monthly from November through April and after any major storm (1 inch in 24 hours)</i>	<i>Standing water in the planter between storms that does not drain freely</i>	<i>Remove sediment or trash blockages; improve end to end grade so there is no standing water 24 hours after any major storm (1 inch in 24 hours)</i>
<i>Flow not Distributed Evenly</i>	<i>Monthly from November through April Annually Required</i>	<i>Flows unevenly distributed through planter width due to uneven or clogged flow spreader</i>	<i>Level the spreader and clean so that flows spread evenly over entire planter width</i>
<i>Settlement/ Misalignment</i>	<i>Annually Required</i>	<i>Failure of planters has created safety, function, or design problem</i>	<i>Planter replaced or repaired to design standards</i>
<i>Constant Baseflow</i>	<i>Monthly from November through April Annually Required</i>	<i>Small, continual flow of water through the planter even after weeks without rain; planter bottom has an eroded, muddy channel</i>	<i>Add a low-flow pea gravel drain the length of the planter or bypass the baseflow around the planter</i>
<i>Vegetation</i>	<i>Monthly from November through April Annually Required</i>	<i>Vegetation blocking more than 10% of the inlet pipe opening</i>	<i>No vegetation blocking the inlet pipe opening</i>
<i>Poor Vegetation Coverage</i>	<i>Monthly Annually Required</i>	<i>Grass or other vegetation is sparse, or bare in more than 10% of the planter area</i>	<i>Determine cause of poor growth and correct the condition; replant with plants (per Appendix A) as needed to meet facility standards</i>
<i>Invasive Vegetation</i>	<i>Monthly Annually Required</i>	<i>No invasive vegetation is planted or permitted to remain</i>	<i>no invasive vegetation present; remove excessive weeds. Control if complete eradication is not feasible</i>
<i>Rodents</i>	<i>Monthly Annually Required</i>	<i>Evidence of rodents or rodent damage</i>	<i>No rodents; functioning facility</i>
<i>Insects</i>	<i>Annually Required</i>	<i>Insects such as wasps and hornets that interfere with maintenance activities</i>	<i>Harmful Insects removed</i>
<i>Trash and Debris</i>	<i>Monthly and after any major storm (1 inch in 24 hours) Annually Required</i>	<i>Visual evidence of trash, debris or dumping</i>	<i>Trash and Debris removed from facility</i>
<i>Contamination and Pollution</i>	<i>Monthly from November through April Annually Required</i>	<i>Any evidence of oil, gasoline, contamination or other pollutants</i>	<i>No contaminants or pollutants present; coordinate removal/cleanup with local water quality response agency</i>
<i>Obstructed Inlet/Outlet</i>	<i>Monthly and after any major storm event (1 inch in 24 hours) Annually Required</i>	<i>Inlet/outlet areas clogged with sediment, vegetation or debris</i>	<i>Clear inlet and outlet; obstructions removed</i>
<i>Excessive Shading</i>	<i>Monthly from November through April Annually Required</i>	<i>Vegetation growth is poor because unlight does not reach planter</i>	<i>Trim over-hanging limbs and/or remove brushy vegetation as needed</i>
<i>Vegetation</i>	<i>Monthly from November through April Annually Required</i>	<i>Specified or approved grass grows so tall that it competes with shrubs and/or becomes a fire danger</i>	<i>String trim non-wetland grasses to 4 inch to 6 inch and remove clippings; protect woody vegetation</i>

Stormwater Facilities Operations & Maintenance Checklist

DRAWING NUMBER: ST-6115

DRAWN BY: SR

SCALE: N.T.S.

FILE NAME: ST-6115.DWG

APPROVED BY: NK

DATE: 10/3/14

CITY OF
WILSONVILLE



PUBLIC WORKS STANDARDS

This Detail Drawing may not be altered or changed in any manner except by the City Engineer. It is the responsibility of the user to acquire the most current version.

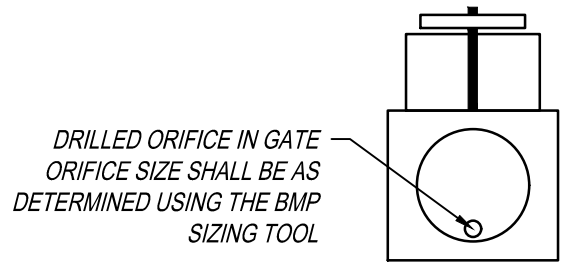

**END VIEW
(PVC GATE VALVE)**

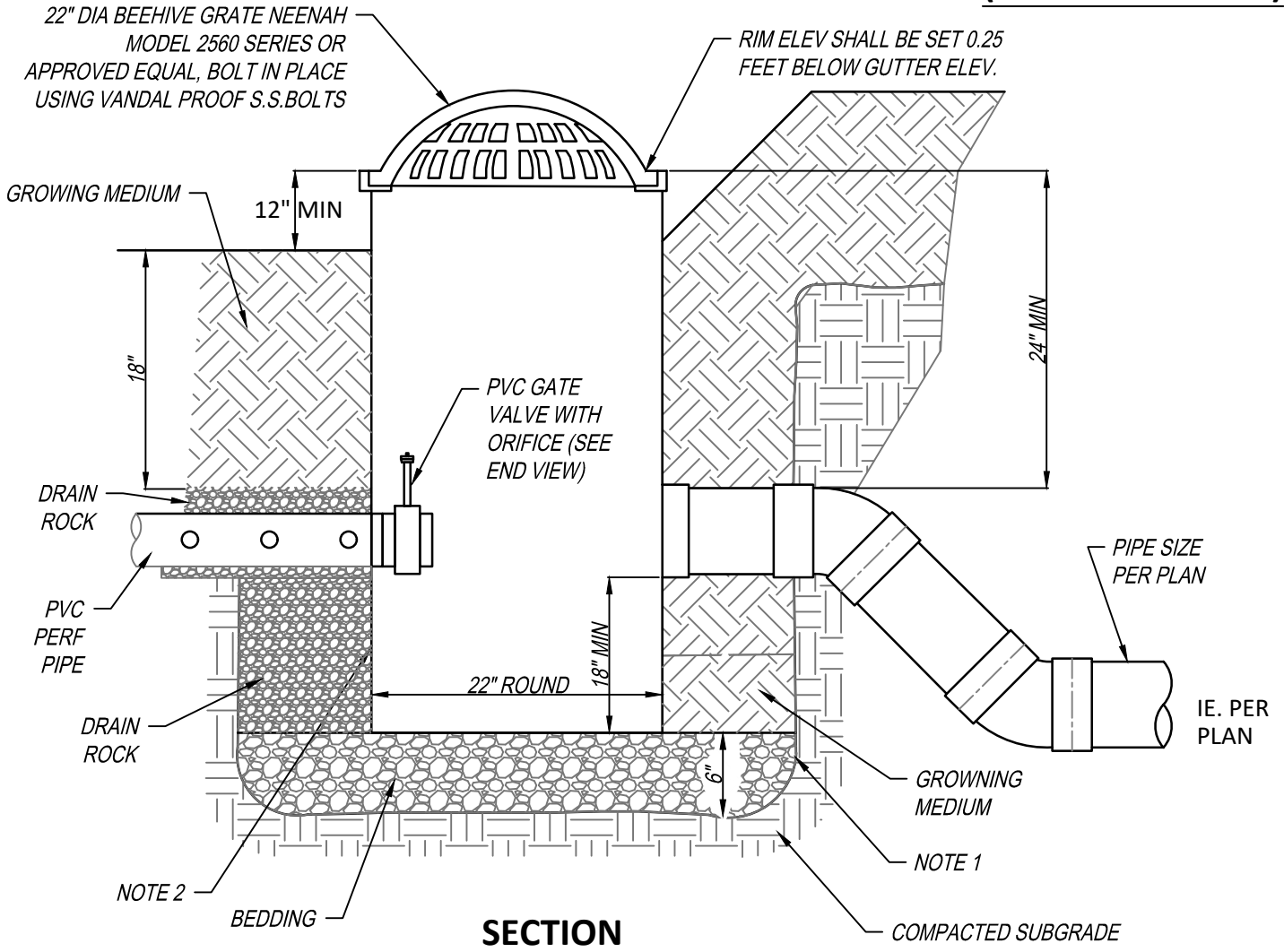

SECTION

NOTES:

1. CONTRACTOR TO WIDEN EXCAVATION AS REQUIRED TO OBTAIN COMPACTION WITH CONTRACTORS COMPACTION EQUIPMENT.
2. 10 GA. STEEL PLATE, BITUMINOUS COATED BASIN AS MANUFACTURED BY GIBSON STEEL, GRATEMASTER OR APPROVED EQUAL.
3. BEDDING SHALL BE 6" OF COMPACTIONED 3/4"-0 CRUSHED ROCK BASE MATERIAL.

Beehive Overflow Inlet			CITY OF WILSONVILLE PUBLIC WORKS STANDARDS 
DRAWING NUMBER: ST-6120	DRAWN BY: SR	SCALE: N.T.S.	
FILE NAME: ST-6120.dwg	APPROVED BY: NK	DATE: 2/15/18	